

# WINGET

## WORKSHOP MANUAL 200T MIXER

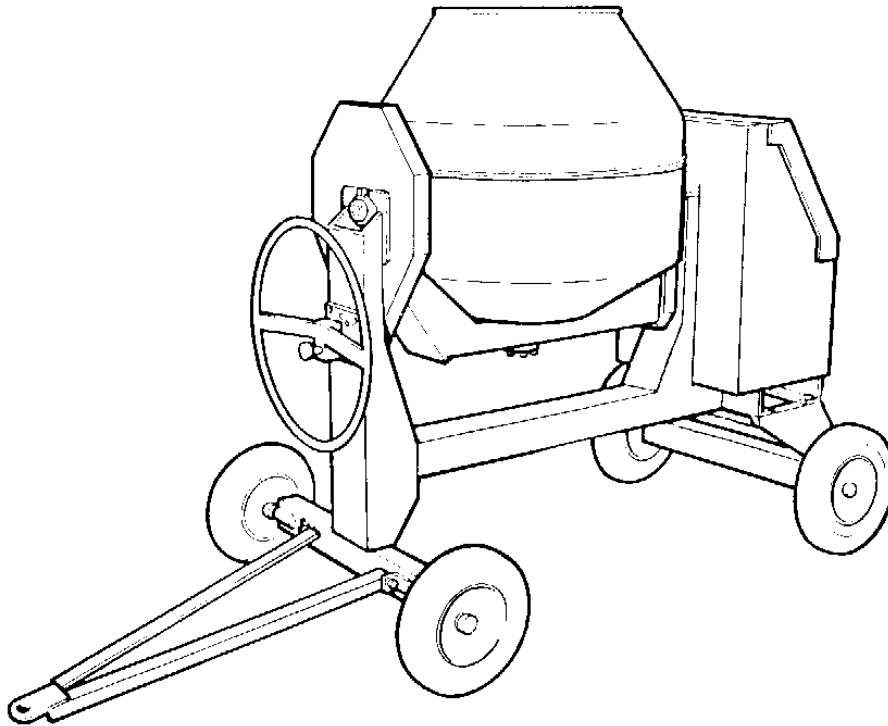

WINGET LIMITED  
PO BOX 41  
EDGEFOLD INDUSTRIAL ESTATE  
PLODDER LANE  
BOLTON  
LANCS  
BL4 OLR  
Tel:- ++ 44 (0) 1204 854650  
service@winget.co.uk  
parts@winget.co.uk  
www.winget.co.uk

FROM 1998  
ISSUE 6 2018

**WORKSHOP MANUAL**  
**Winget Hand Fed Mixers**  
**Models: 200T**  
**From 1998**

---

**CONTENTS**

Section 1	Introduction
Section 2	Repair and Service Procedures
Section 3	General Arrangement Dimensions
Section 4	Service Schedules
Section 5	Lubrication Diagram
Section 6	Wiring Diagrams
Section 7	Noise Levels
Section 8	Special Tools
Section 9	Parts Listings

# **WORKSHOP MANUAL**

**200T**

## **SECTION 1**

### **INTRODUCTION**

# WORKSHOP MANUAL

## Winget Hand Fed Mixers

**Models: 200T**

**From 1998**

---

### **Introduction**

It is assumed that Personnel involved in either the Assembly or repair of Winget Mixers will be familiar with the product, either through the operation of, or previous repair and maintenance work. It is not intended to be used by Personnel who are neither familiar with the product or mechanically inexperienced.

It is also assumed that personnel are aware of the Health and Safety Regulations, which should be applied to all working practices, but the following should act as a reminder.

Ensure all work tools are in good condition.

Always wear Safety Spectacles when using Soft or Hard Faced Hammers, Chisels or when using Air Tools. Wear Safety Spectacles when cleaning Hardened Concrete or Mortar off components.

Do not misuse Air Lines and be aware of the damage Compressed Air can cause if misused.

Always make sure Lifting Equipment is in good condition and the Safe Working Loads exceed the weights of the components to be lifted.

Oils, Fuels, Silicone Sealer and Open Gear Lubricants can cause skin diseases if allowed to contaminate the skin. Always apply barrier creams, wear suitable protective clothing or when contamination is unavoidable clean the area with soap and water as soon as possible. Do not use thinners or other solvents to clean skin.

Health and Safety is a matter of common sense. If common sense is applied correctly Health and Safety can be improved upon and the risk of accidents reduced.

L/H and R/H views are taken when standing directly behind and facing the engine housing.

Whilst every effort is made to ensure the contents of this manual are accurate, Winget Limited accept no responsibility for errors or omissions and reserve the right to alter specification without prior notification and certain sections may then no longer apply.

# **WORKSHOP MANUAL**

**200T**

## **SECTION 2**

### **REPAIR & SERVICE PROCEDURES**

**WORKSHOP MANUAL**  
**Winget Hand Fed Mixers**

**Models: 200T**

**From 1998**

---

**Repair & Maintenance Procedures**

The following procedures are based in part on the procedures issued to Distributors and the instructions should be used in conjunction with the appropriate Parts and Operators Manual or Parts Microfiche. Reference should also be made to the Parts Listings in Section 9 for a guide to the correct sequence for assembling components and sub assemblies.

- 1) Clean any paint or debris from bores and shaft surfaces. Threaded holes should preferably be cleaned out using the correct tap
- 2) All sealed for life bearings should be packed with a good quality grease prior to installation. Carefully remove a seal, pack the bearing with grease and refit the seal ensuring it is correctly seated.
- 3) Apart from installing the electric motor, mounting brackets and conduit as described in this manual under the heading '240 volt single ph Electric Motor,' all wiring and other work concerned with the installation of 240 volt components and supply should be left to a suitably qualified electrician, who is conversant with single ph 240 volt electric circuits.

**WORKSHOP MANUAL**  
**Winget Hand Fed Mixers**  
**Models: 200T**  
**From 1998**

---

**Lifting Points**

A lifting point capable of supporting the weight of the mixer is incorporated into the rear leg of the mainframe.

This lifting point is highlighted with an ISO 'Hook' symbol adjacent to the point.

On Military/Nato mixers the lifting point will also be painted white.

**Solid Rubber/Steel Wheel Replacement.**

The rubber or steel wheels are secured to the axle stub shafts using a collar retained via a long bolt and binx nut. To replace a wheel jack up and support the axle adjacent to the stub shaft, undo and remove the retaining bolt slide off the collar followed by the wheel. Reverse the procedure to replace a wheel not forgetting to lubricate the stub shaft and bore of the wheel with grease prior to assembly.

**Front Axle Removal.**

Using suitable lifting equipment lift and support the mainframe. The Rear axle is a welded component of the mainframe and cannot be removed.

The front axle is retained via a pivot pin, washers and split pins, to remove straighten the split pins and remove from the pivot pin. Using a suitable drift and hammer knock the pivot pin up through the axle and manoeuvre the axle clear. Reverse the procedure to refit not forgetting to coat the pivot pin with anti-seize compound and fit new split pins.

Lower the mainframe and allow to stand back on the wheels, remove the lifting equipment.

**Drawbar-Standard**

The standard drawbar is attached to the front axle via two bolts, flat washers and binx nuts, to remove simply undo and remove the bolts and lift the drawbar clear. Reverse the procedure to refit.

**Drum Removal**

Attach suitable lifting equipment through the drum blades. Knock back the tabs on the tabwasher securing the drum shaft setscrews below the trunnion. Remove the setscrews and washers securing the shaft and flange. With the drum mouth upright lift the drum assembly clear of the trunnion. It may be necessary to rock the trunnion via the tiltwheel to free the drum shaft.

In exceptional circumstances it may be necessary to use a Two-Leg Puller/Pusher Tool to assist in pushing the Drum Shaft through the Trunnion. When using such tools follow the manufacturers instructions.

# WORKSHOP MANUAL

## Winget Hand Fed Mixers

Models: 200T

From 1998

---

### Replacement of Drum Shaft, Bevel Gear and Bearings

Remove the drum as described previously and turn upside down so that the assembly stands on the open mouth of the drum. Before removing the bevel gear from the drum base use suitably sized circlip pliers and remove the large circlip retaining the lower shaft bearing into the gear.

Remove the setscrews securing the bevel gear and shaft assembly to the drum base, use two of the setscrews as jacking screws utilising the threaded holes in the bevel gear and jack the assembly out of the base.

With the assistance of suitable lifting equipment lift the assembly onto a suitable supporting surface and using a soft faced hammer or mallet knock the shaft back through the bevel gear. Support the shaft in a suitable soft jawed vice and remove the smaller circlip from the end of the shaft retaining the upper drum bearing, using a suitable drift or puller remove both bearings from the shaft. Clean all the components.

Before fitting new bearings carefully remove the seals from the bearings and pack the bearings with good quality grease, refit the seals, do not completely fill the bearings with grease leave some room for expansion as the grease warms up in service.

Fit the new bearings to the shaft and retain the upper smaller bearing using a new circlip. Clean out the drum centre shaft housing and smear a little anti-seize compound round the circumference of the upper bearing seat within the housing.

Place the bevel gear on the drum base and loosely retain with the setscrews and washers, apply threadlock to the screw threads before inserting, smear a little anti-seize compound round the circumference of the lower bearing seat in the bevel gear.

Lower the shaft through the bevel gear and using a suitable mallet or soft faced hammer knock the shaft fully home, fit the large retaining circlip and finger tighten the setscrews. Check the gap between the gear and drum base, using a combination of the 2.00, 1.00 & 0.5mm shims pack the gap in 6/8 positions around the circumference of the gear. Tighten the retaining screws. Seal around the circumference of the gear using a suitable sealer. (Once the setscrews are tight it may be necessary to give the end of the shaft a sharp tap with a soft faced mallet to seat the bearings)

### Drum Cone Replacement.

Clean hardened concrete or mortar from around the drum clip and the bolts securing the drum blades. Remove the bolts securing the blades to the drum cone and slacken the bolts through the base. Due to the corrosive action of concrete and mortar it may be necessary to cut through the old bolts using oxy-acetylene equipment. Be aware that hot concrete can "explode" violently spitting concrete - wear suitable eye protection and protective clothing.



# 200T DRUM CLIP FIXING

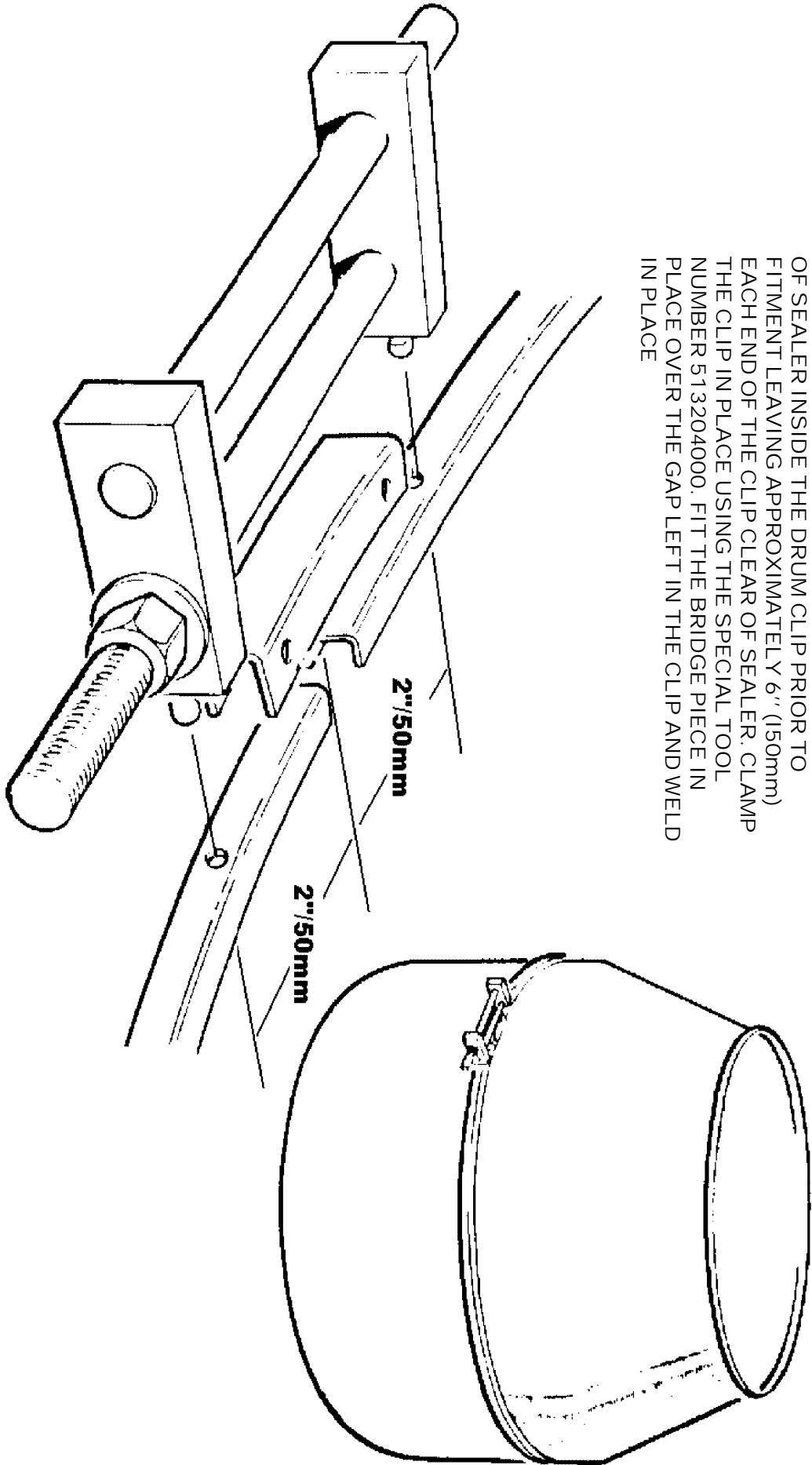

AFTER COATING THE MATING FACES OF THE DRUM BASE AND CONE WITH SILICONE SEALER FIT THE CLIP AROUND THE DRUM AS SHOWN. RUN A BEAD OF SEALER INSIDE THE DRUM CLIP PRIOR TO FITMENT LEAVING APPROXIMATELY 6" (150mm) EACH END OF THE CLIP CLEAR OF SEALER. CLAMP THE CLIP IN PLACE USING THE SPECIAL TOOL NUMBER 513204000. FIT THE BRIDGE PIECE IN PLACE OVER THE GAP LEFT IN THE CLIP AND WELD IN PLACE

# WORKSHOP MANUAL

## Winget Hand Fed Mixers

**Models: 200T**

**From 1998**

---

Cut through the drum clip and remove. Lift off the drum cone. If necessary clean out the drum base. Clean any old silicone sealer and hardened concrete from around the drum flange.

Run a generous bead of silicone sealer around the flange of the drum base and inside the new drum clip. Leave the last 150mm of each end of the clip free from sealer.

Using suitable lifting equipment lift the new drum cone in place lining up the holes in the cone with those in the blades. Loosely refit in the bolts, nuts and washers. Fit the new drum clip around the circumference of the two halves of the drum tapping in place over the flanges using a soft faced hammer.

Attach the special drum clip tool placing the pins on the tool into the holes in each end of the clip.

Using a suitable spanner tighten the drum clip to the drum until it is secure. Do not overtighten the clip or the pins in each end of the tool will shear off. Slip the bridge piece over the remaining gap in the drum clip and weld in place. Remove the tool. Fully tighten the drum blades.

Run the mixer, tilting the drum via the tiltwheel making sure that the drum, clip or bridge piece do not foul the mainframe or guards.

Stop the engine, clean any excess silicone off the drum or clip.

### **Drum Blade Replacement**

It is unlikely that drum blades will require replacement separately to the drum cone. However in the event that it should prove necessary, clean any hardened concrete or mortar from around the bolts securing the blades. Remove the bolts and blades. Due to the corrosive action of concrete and mortar it may be necessary to cut through the old bolts using oxy-acetylene equipment. Be aware that hot concrete can “explode” violently spitting concrete - wear suitable eye protection and protective clothing.

Attach the new blades into the drum assembly finger tighten the bolts until all the bolts are in place. Tighten the bolts.

The bolts should go into the drum from the outside and only round or dome headed bolts should be used.

### **Bevel Gear Guard Replacement**

Remove the drum assembly as previously described. Remove the four setscrews, nuts, etc. holding the guard in place. Fit the new guard tighten the setscrews. Replace the drum assembly as described in the following paragraph.

# WORKSHOP MANUAL

## Winget Hand Fed Mixers

Models: 200T

From 1998

---

### Refitting Drum Assembly

Using suitable lifting equipment lift the drum assembly, check the drum shaft is clean and referring to the Drum Adjustment illustration coat the drum shaft (**J**) and trunnion with anti-seize compound at (**A**).

Turn the drum shaft so the threaded holes in the base of the shaft are at 90 degrees to those in the trunnion base blocks.

Position the drum over the trunnion and lower into place making sure the bevel gear and pinion are fully in mesh and the drum is fully seated down.

Apply anti-seize compound to the drum shaft setscrews and secure the flange to the drum shaft not forgetting the tabwasher. Using the flange turn the drum shaft until the remaining holes in the flange align with the holes in the base block.

Refer to the Drum Adjustment illustration and check the number of flat washers required to fill the gap (**G**) between the flange and base block. Remove one washer from each side. Apply anti-seize compound to the setscrews (**H**) and pass the setscrews through the flange and flat washers, fully tighten the setscrews into the trunnion.

Check for free play between the drum bevel gear and bevel pinion (**C**) by gently rocking the drum (approximately 3mm is acceptable). By using a combination of the varying thickness of washers and shims it is possible to fine tune the backlash. Remove the lifting equipment.

### Tilting Handwheel and Locking Plunger

The tilting handwheel wheel is secured to the tilting pinion via a feather key and M10 grubscrew. With the drum in the vertical position slacken and remove the grub screw, pull off the handwheel. Note on mixers, which have been in service for some time it may be necessary to use a suitable puller on the handwheel.

The locking Plunger is held in place in the Tilting Wheel by a small spiral pin. Knock out this pin and remove the locking plunger. Later mixers are fitted with a spring.

Re-assemble in the reverse order coating the locking plunger and pinion shaft with anti-seize compound.

### Tilting Bracket and Pinion

With the Drum in the vertical position remove the lower tilting pinion guard. Remove the four setscrews securing the tilting bracket taking care not to drop the retaining

plate on the inside of the mainframe front leg. Lift the pinion teeth clear of the tilting chain, remove the inner retaining bracket and lift out the tilting bracket assembly.

Remove the handwheel as described above, remove the feather key and using a soft faced hammer knock the tilting shaft and pinion out of the bracket. Check the

# 200T DRUM ADJUSTMENT

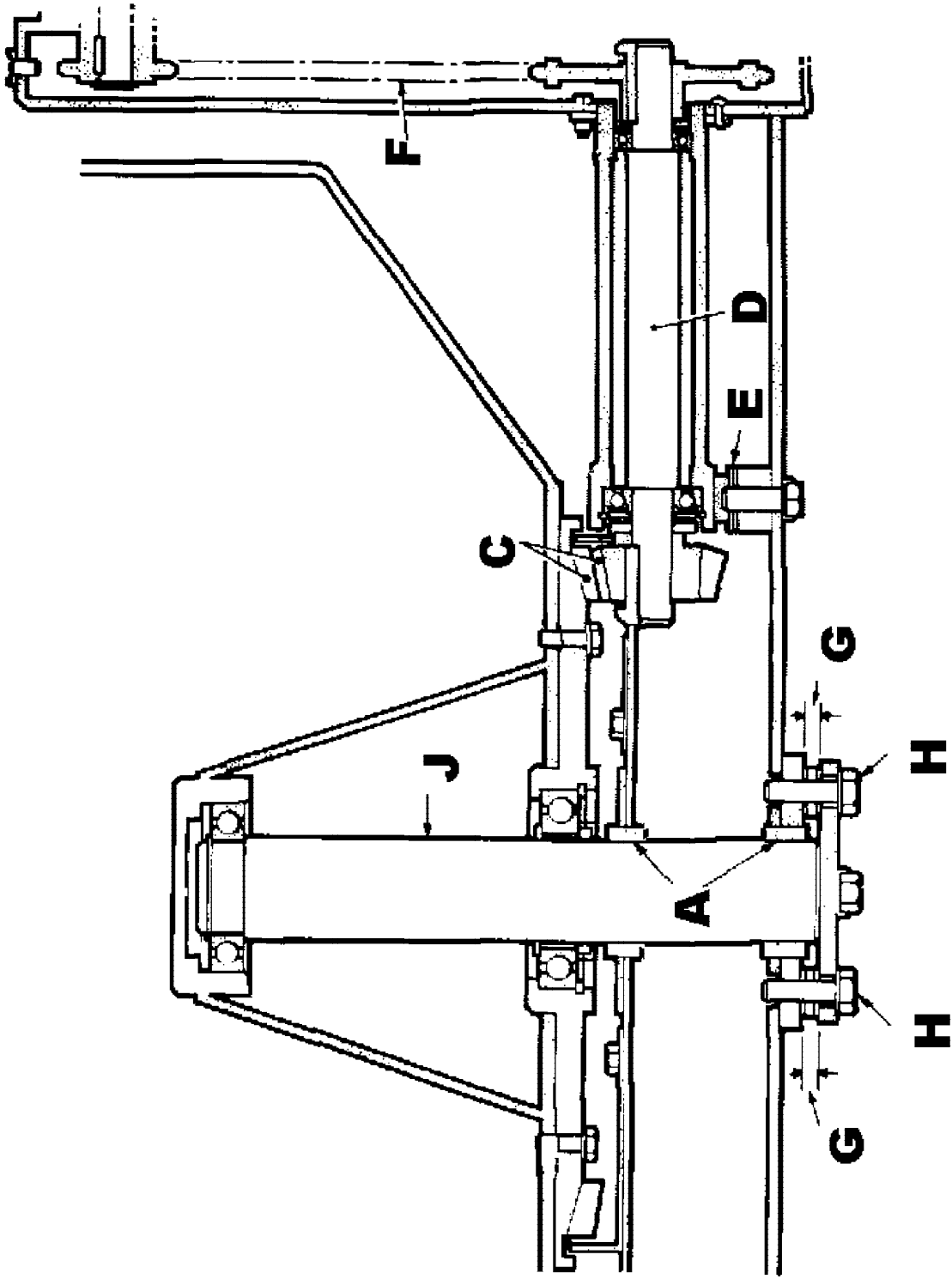

# WORKSHOP MANUAL

## Winget Hand Fed Mixers

**Models: 200T**

**From 1998**

---

condition of the bushes and replace and/or lubricate as required. Note, very occasionally new bushes will require reaming to size.

Reassemble the tilting bracket in reverse order lubricating bushes with engine oil. Coat shafts, pinions and plungers with anti-seize compound.

When refitting the tilting bracket assembly to the mixer engage and lock the plunger into the lower single hole in the bracket whilst ensuring the drum is still vertical. Pass the assembly through the front leg of the mainframe, slip the retaining plate over the bracket before engaging the pinion into the tilting chain.

Align the bracket and inner retaining plate with the slots in the front leg and insert the setscrews and washers. Finger tighten the setscrews to hold the bracket in place and slide the assembly in the slots to correctly tension the tilting chain, fully tighten the four setscrews. Refit the lower tilting pinion guard.

Turn the handwheel and check the drum and trunnion operate correctly and contact the travel stops without unduly stressing the tilting chain.

### **Tilting Chain**

To access the tilting chain remove the upper and lower chain guards behind the front plate of the trunnion. The chain is anchored to the trunnion end plate by means of two split links one in each end of the chain.

To replace the chain, place the drum in the vertical position and engage the handwheel locking plunger in the lower single hole. Slacken the four setscrews retaining the tilting bracket and lift the bracket in the slots to release any tension on the chain, tighten at least one of the setscrews to hold the bracket in place. Separate the split links and unhook the chain. Reverse the procedure to refit the chain adjusting the final chain tension by sliding the tilting bracket in the slots. Refit the guards and check the trunnion contacts the travel stops without unduly stressing the chain.

### **Countershaft/Bevel Pinion Drive Chain.**

Remove the chain guard from the rear of the trunnion. Crank the engine over until the chain split link is visible. Disconnect the split link, hook the new chain loosely onto the split link slowly crank the engine and pull the new chain in place round the countershaft sprocket. Remove the old chain and link. Loop the new chain round the sprocket in the bevel pinion shaft and fit the new split link. The open end of the split end should point away from the normal direction of rotation, which is anti-clockwise when looking directly at the chain. Check and adjust the chain tension. (See Bevel Pinion Shaft and Housing). Refit the chain guard.

# WORKSHOP MANUAL

## Winget Hand Fed Mixers

**Models: 200T**

**From 1998**

---

### **Bevel Pinion Shaft and Housing**

Follow the procedures described earlier and remove the drum, bevel gear guard and disconnect the countershaft bevel pinion drive chain.

Rotate the trunnion until it reaches its highest point and lock in place. Remove the gib head key securing the sprocket to the bevel pinion shaft. Remove the bevel pinion guard, release the tabwashers and remove the setscrews, packers and shims securing the bevel pinion housing. At this point the bevel pinion housing should be supported by a second pair of hands, strapped or supported in some other manner to prevent it dropping down sharply and causing damage to the casting, it will otherwise only be secured by the loose fitting retaining plate and sprocket.

Remove the nuts and washer off the two bolts retaining the bevel pinion housing adjusting plate. Using a soft faced hammer knock the bevel pinion shaft through the sprocket until it is possible to remove the sprocket. Remove the bolts through the retaining plate and lift the bevel pinion housing out of the trunnion.

Clamp the housing in a soft jawed vice and remove the gib head key retaining the bevel pinion and pull off the bevel pinion.

Remove the circlip from the groove within the housing and using a soft faced hammer knock the shaft and bearings out of the housing. The bearings can now be removed from the shaft.

Carefully remove the seals from the bearings and pack the bearings with good quality grease, refit the seals, do not completely fill the bearings with grease leave some room for expansion as the grease warms up in service.

To reassemble secure the bevel pinion shaft into a soft jawed vice. Using the correct size of Bearing tube and a soft faced hammer or suitable drift fit the bearings to the shaft. Note the larger of the two bearings is fitted to the longer shank of the shaft.

Remove the shaft from the vice and using the vice support the bevel pinion housing. Using the correct size of bearing tube or suitable drift and the soft faced hammer knock the shaft fully into the housing. Fit the retaining circlip into the groove within the housing. Check the shaft turns freely.

Assemble the bevel pinion to the shaft, fitting the gib head key. The pinion is fitted to the longer shank of the shaft. If correctly assembled the threaded holes in the casting will be at the same end. Do not at this stage fit the sprocket to the opposite end of the bevel pinion assembly, as this will prevent re-assembly of the housing back into the trunnion.

Loosely fit the triangular adjusting plate back into the trunnion, locating the plate on the peg. Fit the two bolts through the adjusting plate from the rear of the trunnion so

# WORKSHOP MANUAL

## Winget Hand Fed Mixers

**Models: 200T**

**From 1998**

---

that when assembled the head of the bolts will be sandwiched between the trunnion rear plate and the bevel pinion shaft drive sprocket.

Work the bevel pinion housing back into the trunnion and through the adjusting plate. As the shaft protrudes through the rear of the trunnion slide on the sprocket until it is fully home.

Refit the setscrews, tabwashers, packer and shim set retaining the bevel pinion housing and finger tighten only.

Fit the gib head key retaining the drive sprocket and refit the drive chain, when connecting the split link the open end of the link should be fitted so that it points away from the normal direction of rotation which is anti-clockwise when looking directly at the chain.

Release the trunnion and turn back to its lowest position.

Refer to the Drum Adjustment illustration. The adjusting plate holding the rear of the bevel pinion housing (**D**) is slotted to allow the housing to move up and down enabling correct adjustment of the chain tension (**F**). Check and adjust the chain tension and tighten the bolts holding the adjusting plate. By adding or subtracting shims (**E**) between the thick packer and the bevel pinion housing ensure the housing is horizontal in the Trunnion and square to the rear plate. Re-check the chain tension and fully tighten the bolts and setscrews securing the bevel pinion housing (**D**), knock over the tab washers.

Crank the engine ensuring both the countershaft and bevel pinion turn freely. Coat the bevel pinion with open gear lubricant and fit the pinion guard. Fit the rear chain guard.

Following the procedures described earlier refit the bevel gear guard and drum assembly.

### **Countershaft, Trunnion Journal and Driven Chainwheel/ 'V' Pulley**

Although it is recommended that the trunnion is removed completely from the mixer should the countershaft or trunnion journal require attention it is possible to leave the trunnion assembly in place provided it is properly supported.

Remove the engine housing lid, top plate, engine housing chain guard and infill plate. Slacken the two bolts through the bevel pinion housing adjusting plate and the two setscrews which secure the casting at the pinion end to release the tension on the countershaft chain.

Disconnect the split links retaining both the engine drive and countershaft chains and remove the chains. On 240v electric drive and Yanmar electric start diesel mixers the drive is transmitted to the countershaft by means of a 'V' belt in place of the chain.

# WORKSHOP MANUAL

## Winget Hand Fed Mixers

**Models: 200T**

**From 1998**

---

The 'V' belt drive pulley for the Yanmar differs from the electric motor in that it has a smaller diameter and is retained by means of a taper lock bush.

Withdraw the gib head key retaining the driven chainwheel/'V' belt pulley to the countershaft and pull off the chainwheel/pulley. On Yanmar powered equipment release the taper lock bush and slide off the pulley assembly and flat washer.

Lock the drum in the vertical position using the handwheel locking plunger and using suitable lifting equipment, jacks or chocks secure the trunnion to prevent it moving when the journal is withdrawn.

Remove the two setscrews retaining the journal casting to the mainframe, take the weight off the trunnion and withdraw the journal from the trunnion.

Support the assembly in a soft jawed vice, remove the circlip retaining the countershaft sprocket and pull off the sprocket, remove the feather key. Remove the circlip in front of the bearing and using a soft faced hammer and suitable drift knock the shaft out of the journal from the opposite end.

Remove the bearings and clean all the components. Carefully remove the seals from the new bearings and pack the bearings with good quality grease, refit the seals, do not completely fill the bearings with grease leave some room for expansion as the grease warms up in service.

Reverse the procedure to re-assemble using a suitable bearing tube or drift to seat the front bearing into the housing, retain with the circlip. Pass the countershaft (end with feather key way and circlip groove) through the housing and into the bearing and knock fully home using a soft faced mallet or hammer. Fit the second bearing over the shaft and knock fully home using a bearing tube or drift until it contacts the shoulder on the shaft.

Fit the feather key, slide on the small sprocket and retain with the circlip. Smear a little grease around the circumference of the trunnion/journal bearing face and in the bore of the corresponding bearing boss on the trunnion. Slide the journal fully home into the end of the trunnion and retain using the two setscrews. Remove the chocks, lifting equipment or jacks and tighten the setscrews fully.

Coat the end of the countershaft with anti-seize compound and slide on the chainwheel/'V' belt pulley, pushing fully onto the shaft, fit the gib head key. On Yanmar powered equipment re-assemble the taper lock bush arrangement not forgetting the flat washer behind the pulley assembly.

Refit both the countershaft chain and the engine chain/'V' belt, ensuring that the open end of the chain split links point away from the normal direction of rotation.

Adjust the countershaft chain tension (refer to the 'drum adjustment illustration' and 'bevel pinion housing') and tighten the bevel pinion housing, check the engine drive



# WORKSHOP MANUAL

## Winget Hand Fed Mixers

**Models: 200T**

**From 1998**

---

chain tension or 'V' belt pulley tension, adjust the tension as necessary. On LT1/LV1 diesel engines adjust the shimming below the engine (see 'engines'), on 240V electric drive machines and Yanmar electric start diesel engines move the motor/engine either upwards or downwards on the threaded adjusters as required.

Fit the infill plate, chain guards and plastic plug, top plate and engine-housing lid and closing plate. Release the locking plunger and operate the handwheel ensure the trunnion tilts correctly, start the engine or motor and check the operation of the drum drive, also check for unusual noises.

### **Front Trunnion Bearing Replacement**

Lock the drum and trunnion in the vertical position using the handwheel locking plunger. Using suitable lifting equipment, jacks or chocks support the trunnion just behind the front leg of the mainframe.

Remove the two nuts and washers securing the profiled retaining plate, take the weight of the trunnion and pull off the plate and bearing boss. Clean all parts. Reverse the procedure to refit, not forgetting the grease nipple which also prevents the bearing from turning. Remove the chocks, jacks or lifting equipment.

### **Trunnion Removal/Replacement**

Remove the drum, engine housing lid, top plate, chain guards and infill plate in the engine housing. Remove the upper and lower tilting chain guards and remove the tilting chain. Remove the engine drive chain, undo and remove the two setscrews retaining the journal and the two nuts securing the front bearing, attach lifting suitable equipment to the trunnion and take the weight, remove the front bearing.

Note, to remove the trunnion fully it will be necessary to rotate the trunnion as it is being lifted in order for it to clear the engine housing.

Slide the trunnion towards the engine housing until it can be seen that the travel stop pegs welded in the front leg and trunnion end plate are clear of each other, rotate the trunnion and move backwards and upwards to clear the engine housing.

Place the trunnion on a suitable surface and remove the bevel pinion housing and journal as previously described.

Reverse the procedure to rebuild the trunnion and refit it into the mixer referring to the relevant sections to set up bevel pinion, journal, front bearing, drum etc.

### **Engine LT1/LV1-10 Hand Start**

"CE" marked machines are fitted with 'anti-kick back starting handles' in order to comply with local legislation. For information on the starting handles refer to the engine operators handbook or engine workshop manual.

# WORKSHOP MANUAL

## Winget Hand Fed Mixers

**Models: 200T**

**From 1998**

---

For details on engine services or overhauls, changing engine oils, filters and bleeding the fuel system refer to the engine operator's handbook or engine workshop manual.

Note, the engine is set to run at 1500 rpm and rotates clockwise at the flywheel end.

### **Drive Sprocket Removal/Replacement**

On the LT1/LV1-10 the Sprocket is keyed onto the engine extension shaft and also held by an M8 grubscrew. Replacement of the sprocket requires removal of the engine.

Remove the engine housing closing plate, engine housing lid, top plate and chain guards. Disconnect the drive chain. Remove the exhaust pipe, remove the bolts securing the engine mounting channels to the engine bed. Using suitable lifting equipment remove the engine taking care not to lose the shims.

Remove the gib head Key and pull off the sprocket. It may help release the key if the sprocket is knocked backwards on the shaft away from the head of the key. Coat the shaft and bore of the sprocket with anti-seize compound and slide on the new sprocket with the boss towards the engine and retain approximately 17mm from the end of the shaft using the gib head key. Do not at this stage fully fit the key in case the sprocket needs to be aligned with the countershaft chain wheel when the engine is refitted.

Lift the engine back into the mainframe and align the mounting channels with the holes in the bed. Insert the bolts but do not fully tighten, refit the shim pack and re-connect the chain. Check the alignment of the sprockets by moving the sprocket on the shaft as necessary before fully inserting the gib head key and tightening the grubscrew.

Check and adjust the chain tension by adding or subtracting engine shims. The tension is correct when the chain deflects approximately 5mm about the centre line of the chain. The chain tension should be checked midway between the two sprockets. When the tension is correct fully tighten all the bolts and recheck the chain tension.

A chain running too tight will cause starting problems and the increased loadings will increase the rate of wear on the chain and sprocket and may also damage the crankshaft bearings. A chain running too slack may run off the sprocket or chainwheel.

Refit the exhaust pipe, retaining clamps and brackets, refit the engine housing lid, chain guards not forgetting the polythene plug, top plate and closing plate.

### **Engine Yanmar L40/L48-ARE SE Electric Start**

There is no difference in build specification between "CE" marked machines intended for use in the European Union or those intended for export elsewhere. No starting

# WORKSHOP MANUAL

## Winget Hand Fed Mixers

**Models: 200T**

**From 1998**

---

handles are fitted to the Yanmar engines, instead a recoil rope starter is fitted as an 'emergency' back up starting device in the event that the electrical starting system should fail. Note, starting the engine with the recoil in the absence of the battery or start key may damage the charging system.

For details on engine services or overhauls, changing engine oils, filters and bleeding the fuel system refer to the engine operator's handbook or engine workshop manual.

Note, the 'high speed' engine is set to run at 3000 rpm and rotates clockwise at the half speed (1500) PTO shaft extension.

To prevent the characteristics of chain drives damaging the Yanmar engine which lacks the heavy flywheel of the slow speed Lister Petter LT1/LV1, the countershaft chainwheel and engine drive chain are replaced by a "V" belt and "V" drive pulleys.

The engine is also mounted differently in that it is bolted to a height adjustable bedplate, similar to the electric 240 volt motor to allow for belt tensioning.

### **Battery Removal/Replacement**

The 12-volt battery is secured on the R/H side of the Yanmar engine within the engine housing for security. To remove, unscrew the 'T' handle from the stop control rod and remove the closing plate. The battery is retained by a non-conductive clamping block, cover and threaded studs, the studs pass through the clamp block screw down into and through the engine mounting plate being retained below the plate with two M6 nuts. Remove the nuts, unscrew the studs and remove, lift off the cover and clamp block, disconnect the battery leads and slide out the battery. Reverse the procedure to refit the battery.

### **Drive Pulley Removal/Replacement**

The drive pulley is keyed onto the engine extension shaft and also held by a small grubscrew through the pulley shank. An M8 setscrew and flat washer is also screwed into the end of the engine extension shaft to retain the pulley. Replacement requires the removal of the engine.

Unscrew the 'T' handle from the stop control rod where it passes through the closing plate. Undo the knot in the recoil rope retaining the handle where it passes through the side of the engine housing, do not release the rope but remove the handle and pass the rope back through into the housing. Tie a loose knot in the rope to prevent it being pulled inside the recoil housing under spring tension. Alternatively the recoil can be removed from the engine and allowed to hang inside the engine housing. To remove the recoil mark its position on the flywheel housing and remove the three small screws which retain the assembly in place.

Remove the engine housing closing plate, engine housing lid, top plate and chain /belt guards. Remove the 'V' belt and unbolt the electrical panel from the side of the mainframe, disconnect the battery. Remove the bolts securing the engine to the

# WORKSHOP MANUAL

## Winget Hand Fed Mixers

**Models: 200T**

**From 1998**

---

mounting plate and carefully lift the engine out of the housing. Turn the engine through 180° to access the drive pulley and rest the engine back on the mounting plate taking care it does not topple off.

Slacken the grubscrew and remove the setscrew and washer, pull off the pulley, it may be necessary to use a small two legged puller if the pulley has been attached for some time.

Coat the bore of the pulley and the extension shaft with anti-seize compound and slide the pulley onto the shaft fully home up to the shoulder, fit the key, grubscrew, setscrew and washer.

Lift the engine back into the mainframe and secure to the bed. Insert the bolts but do not fully tighten and refit the 'V' belt check the belt alignment and tighten the engine retaining bolts.

Check and adjust the belt tension by means of the long threaded adjusting screws the tension is correct when the belt deflects approximately 8-12mm about the centre line of the belt. The tension should be checked midway between the two pulleys. When the tension is correct fully tighten all the bolts and recheck the tension.

A belt running too tight will cause starting problems and the increased loadings will increase the rate of wear on the belt causing it to stretch prematurely and may also damage the crankshaft bearings. A belt running too slack will slip under load with the result that the drum will cease to revolve.

Reconnect the battery and electric start panel, ensuring the wiring is secured and will not chafe through.

Refit the recoil assembly or rope handle, engine housing lid, chain/belt guards not forgetting the polythene plug, top plate, closing plate and stop control 'T' handle.

### **240 Volt 1PH Electric Motor**

The motor runs at approximately 1420/1470 rpm and rotates Clockwise.

To accommodate the reduction in rpm at the motor and to prevent the characteristics of chain drives damaging the motor, the countershaft chainwheel and engine drive chain are replaced by a "V" belt and "V" drive pulley.

The motor is also mounted differently to the Lister Petter LT1/LV1 in that it is bolted to a height adjustable bedplate, similar to the Yanmar engine to allow for belt tensioning.

The contactor enclosure is attached to the chain/belt guard and a key lockable 'emergency' stop button is fitted to the exterior of the engine housing on the left-hand side.

# WORKSHOP MANUAL

## Winget Hand Fed Mixers

**Models: 200T**

**From 1998**

---

Note, locking off the stop button prevents any un-authorized person from starting the equipment BUT does not isolate the electricity supply, before carrying out any work on the motor, contactor or enclosure isolate the supply at the main distribution board and attach a suitable 'locked out' tag to prevent the supply being inadvertently re-connected.

Refer to the wiring diagram for details of the connections between the motor, contactor and emergency stop button.

### **Belt Drive Pulley Removal/Replacement**

The drive pulley is mounted onto the motor extension shaft, and is secured with a feather key and grubscrew.

Unlike the diesel driven versions it is possible to remove the pulley without removing the motor. To remove the pulley, first disconnect the electrical supply and isolate the mixer. Remove the engine housing lid, closing and top plates, upper and lower belt guard and 'V' belt. When removing the upper belt guard take care as the contactor is attached. Mark the position of the pulley on the shaft. Turn the motor shaft until the grubscrew is visible, slacken the screw and remove the pulley. Reverse the procedure to refit coating the bore of the pulley with anti-seize compound prior to assembly.

Fit the "V" belt and confirm the alignment of the pulleys. Adjust the height of the motor to tension the "V" belt. The tension is correct when the belt deflects 8-12mm check midway between the pulleys.

A belt running too tight may cause starting problems and the increased loadings will increase the rate of wear on the belt causing it to stretch prematurely and may also result in damage to the motor shaft bearings. A belt running too slack will slip under load with the result that the drum will cease to revolve.

Refit the engine housing lid, closing and top plates and upper and lower belt guards. not forgetting the plastic plug, take care not to damage the contactor when refitting the upper belt guard. Reconnect the electrical supply.

# **WORKSHOP MANUAL**

**200T**

## **SECTION 3**

### **GENERAL ARRANGEMENT DIMENSIONS**

## DIMENSIONS & GENERAL ARRANGEMENT

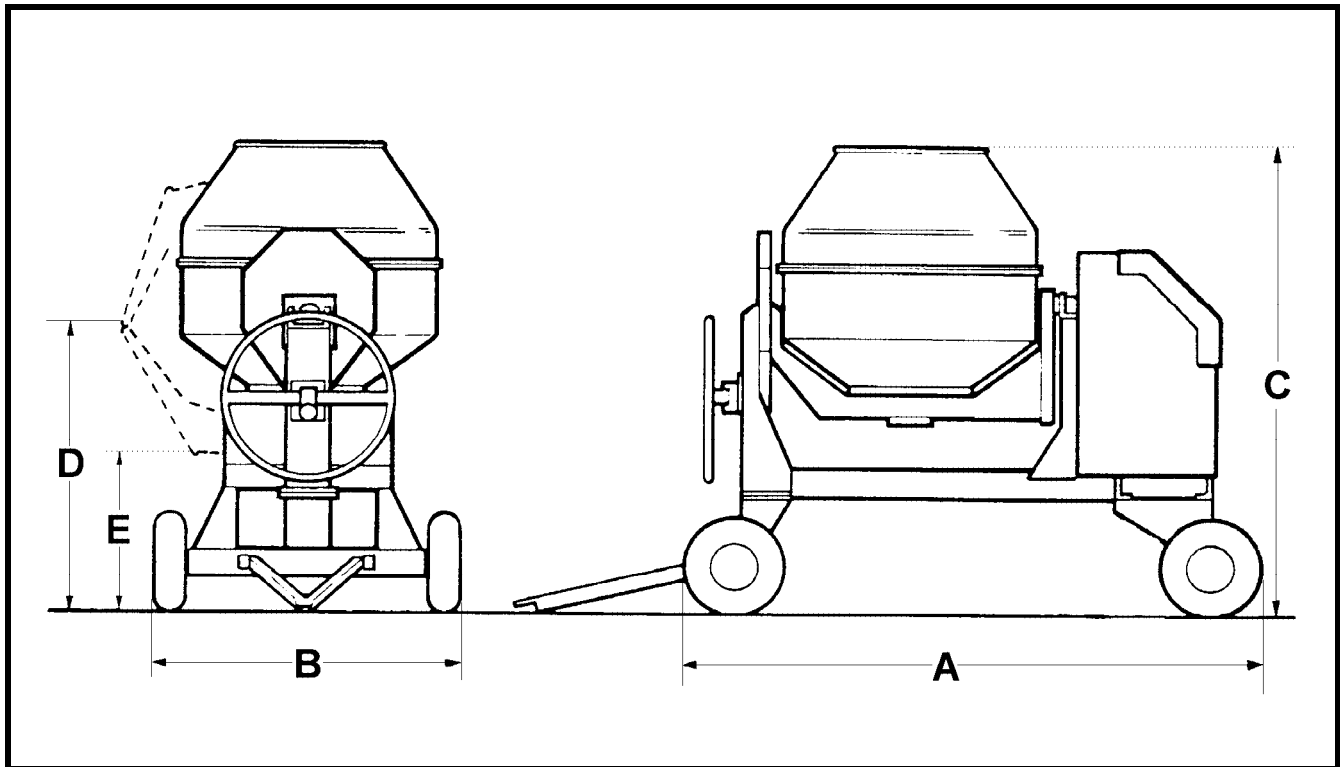

Dimensions are in millimetres

A	Overall length	2208
B	Overall width	1320
C	Overall height	1825
D	Loading height	1130
E	Discharge Height	660
-	Weight (approx)	600Kg

# **WORKSHOP MANUAL**

**200T**

## **SECTION 4**

### **SERVICE SCHEDULES**



**WORKSHOP MANUAL**  
**Winget Hand Fed Mixers**  
**Models: 200T**  
**From 1998**

---

**Service Schedule**

The engine will require additional services or adjustments in addition to those listed below. (See the appropriate Engine Operators Handbook or Workshop Manual)

**Daily: (8) Hours**

**Before Work**

- Lubricate all grease points.
- Check fuel and lubricating oil levels.
- Check for oil and fuel leaks.
- Check/clean/replace air filter element

**After Work**

- Top up fuel tank.
- Clean out drum and hopper.
- Wash down the mixer.

**Weekly: (40 Hours)**

The above and the following:

- |                      |  |
|----------------------|--|
| Drive Chain/Belt     | Check tension, adjust if necessary   |
| Controls and Pivots  | Lubricate all levers, rods, pivots and pins with oil                         |
| Tilting Pinion Chain | Check Tension  |
| Battery (if fitted)  | Check terminals, clean if necessary, top up                                  |
| Drum Drive           | Inspect and lubricate the chain and teeth of the drum bevel gear and pinion. |

**WORKSHOP MANUAL**  
**Winget Hand Fed Mixers**  
**Models: 200T**  
**From 1998**

---

**Monthly: (100 Hours)**

The above and the following:

Check tightness of nuts, bolts etc.

**Every 3 Months: (300 Hours)**

The above and the following:

Engine

Change air filter element

Change lubrication oil and filter

Change fuel filter

Check valve clearances

(Also see relevant Engine Handbook/Workshop Manual)

**Every 6 Months: (600 Hours)**

The above and the following:

Engine

Check the fuel injection timing (Yanmar)

Clean fuel injectors

**Every 12 Months: (1200 Hours or earlier if conditions dictate)**

The above and the following:

Engine

Decarbonise if necessary

Check Fuel Injection pump

# **WORKSHOP MANUAL**

**200T**

## **SECTION 5 LUBRICATION DIAGRAMS**

# LUBRICATION POINTS

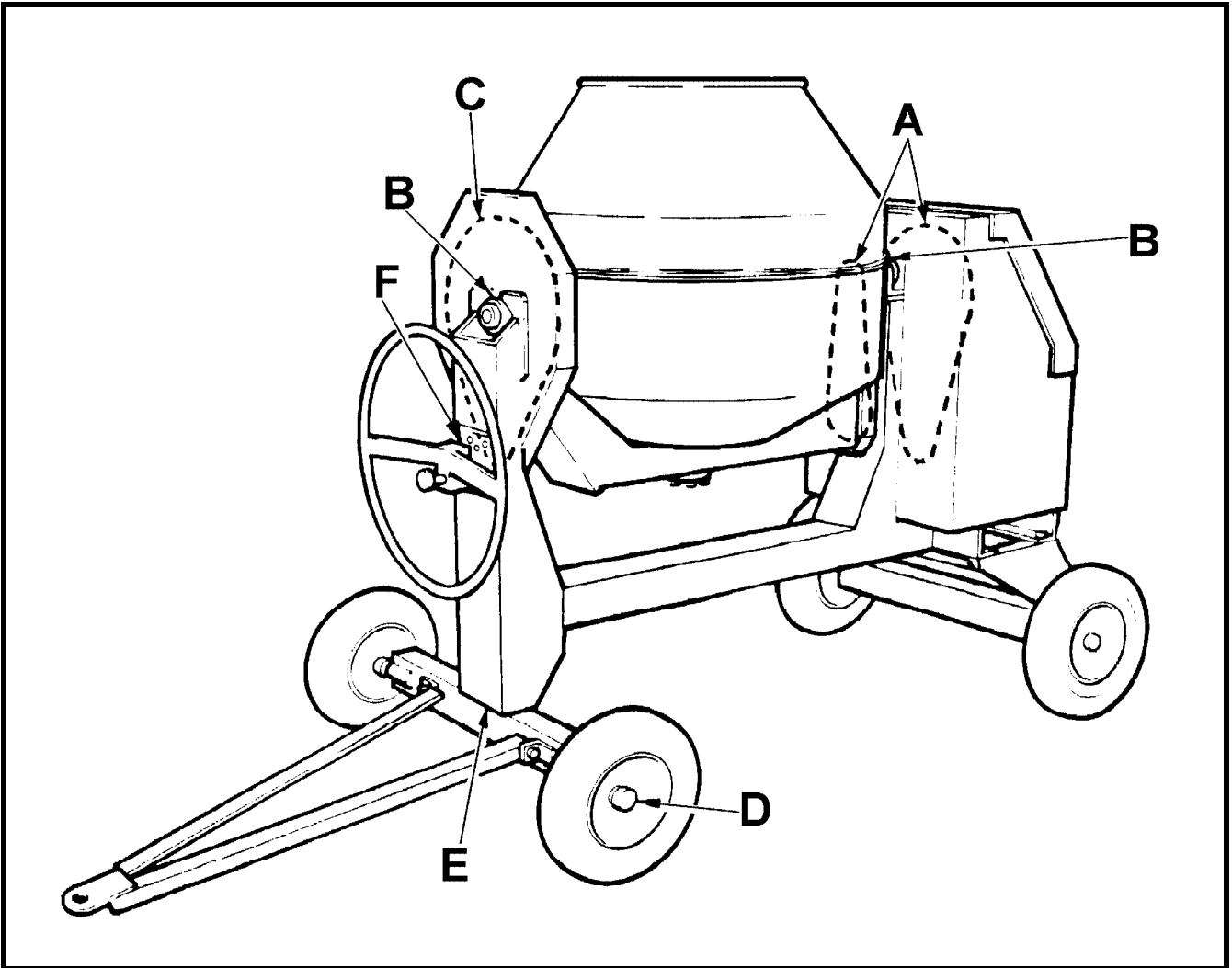

Lub Point	Type	Use	No of Points
A	Drive Chains	Oil	2
B	Trunnion Pivots	Grease	2
C	Tilt Chain	Oil	1
D	Wheels	Oil	4
E	Steering Joint	Oil	1
F	Tilt Wheel	Grease	1

## **LUBRICANTS**

**MIXERS ARE FACTORY FILLED WITH THE FOLLOWING TOTAL-FINA OILS & GREASES**

Engines	Rubia B10W/30 Oil
Electric Motor Bearings	Multis EP2 Grease
Drive Chain	Rubia B20W/30 Oil
Bevel Gears	Open Gear Lubricant
Drum Shaft	Anti-seize Compound
Grease Nipples	Multis EP2 Grease
Linkages & Hinges	Rubia B20W/30 Oil
Pivots	Rubia B20W/30 Oil
Bearings (on assembly)	Multis EP2 Grease

**Refer to your local oil supplier for a list of the locally available equivalent grades**

## **MIXER DRUM SEALANT**

Silicone Sealant

Winget Part No : V2000772

# **WORKSHOP MANUAL**

**200T**

## **SECTION 6**

### **WIRING DIAGRAMS**

# 200T ELECTRICAL WIRING DIAGRAM

## ELECTRICALLY DRIVEN MIXERS WIRING CIRCUIT

Electrical connections must only be made by a suitably qualified electrician or competent person

### Reset Switch and Cover

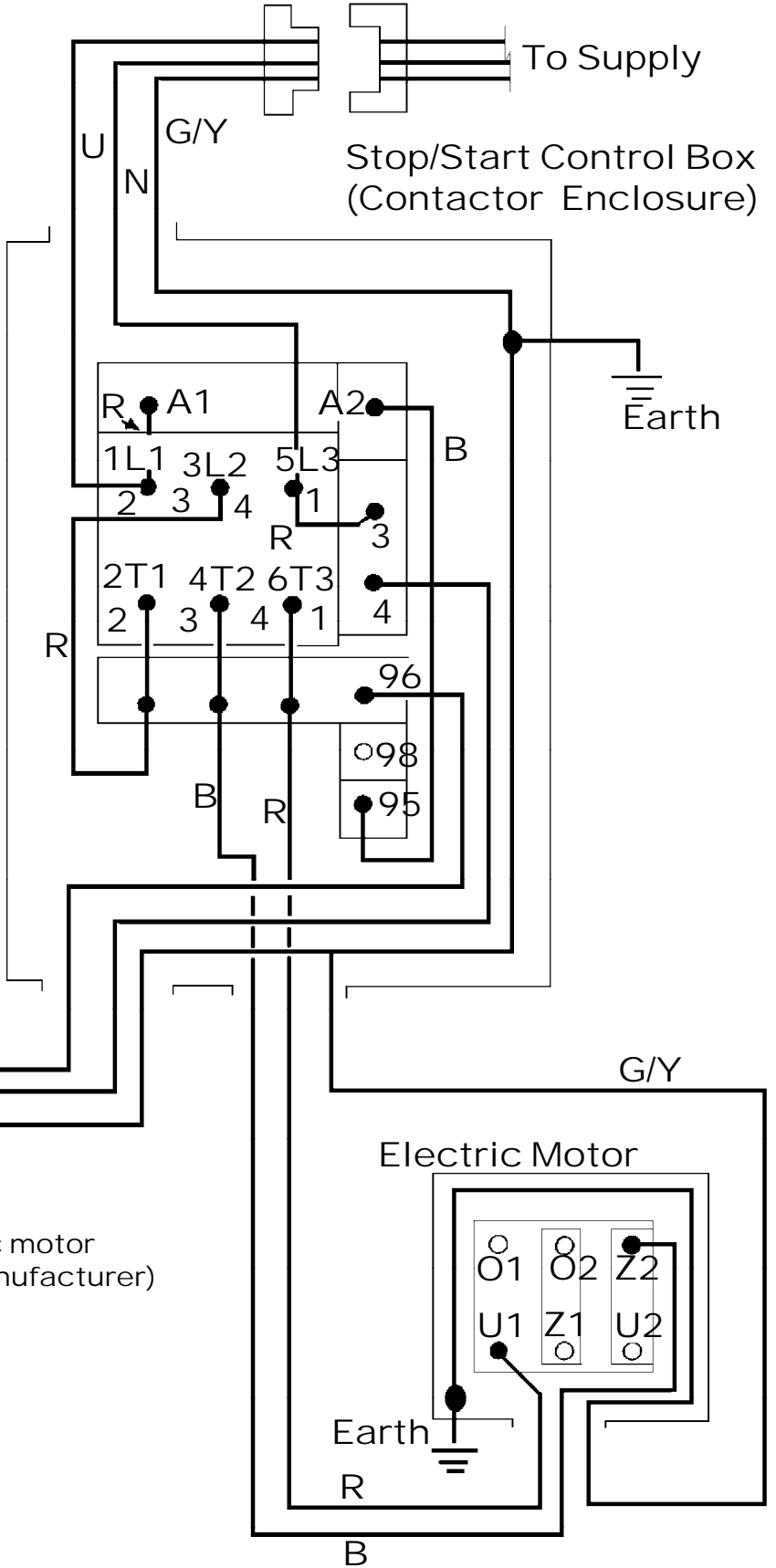
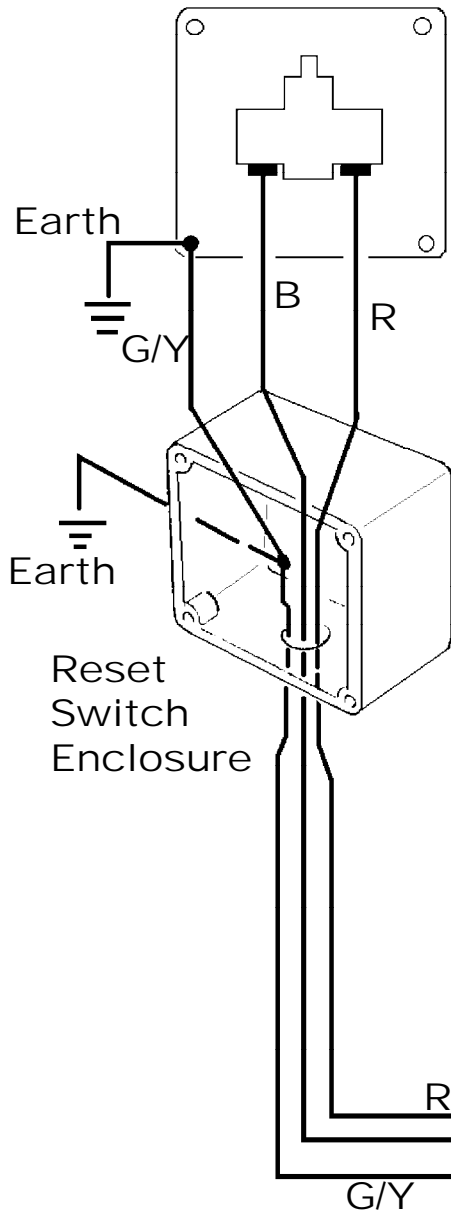

Notes:  
Typical connections within electric motor  
(may differ depending on motor manufacturer)

- Link: U2 - Z2
- Red wire: U2
- Link: Z1 - O2
- Brown wire: O2
- Grey wire: Z1
- Yellow/Black wire: O1
- Yellow/White/Blue wire: U1

Stop/Start Control Box (Contactor/Enclosure):

Remove link wire between contacts 4 and 96

## TECHNICAL INFORMATION

### YANMAR L40/L48 KEY START WIRING CIRCUIT

In addition to the circuit shown below, the engine is fitted with its own loom.  
(see Yanmar service literature)

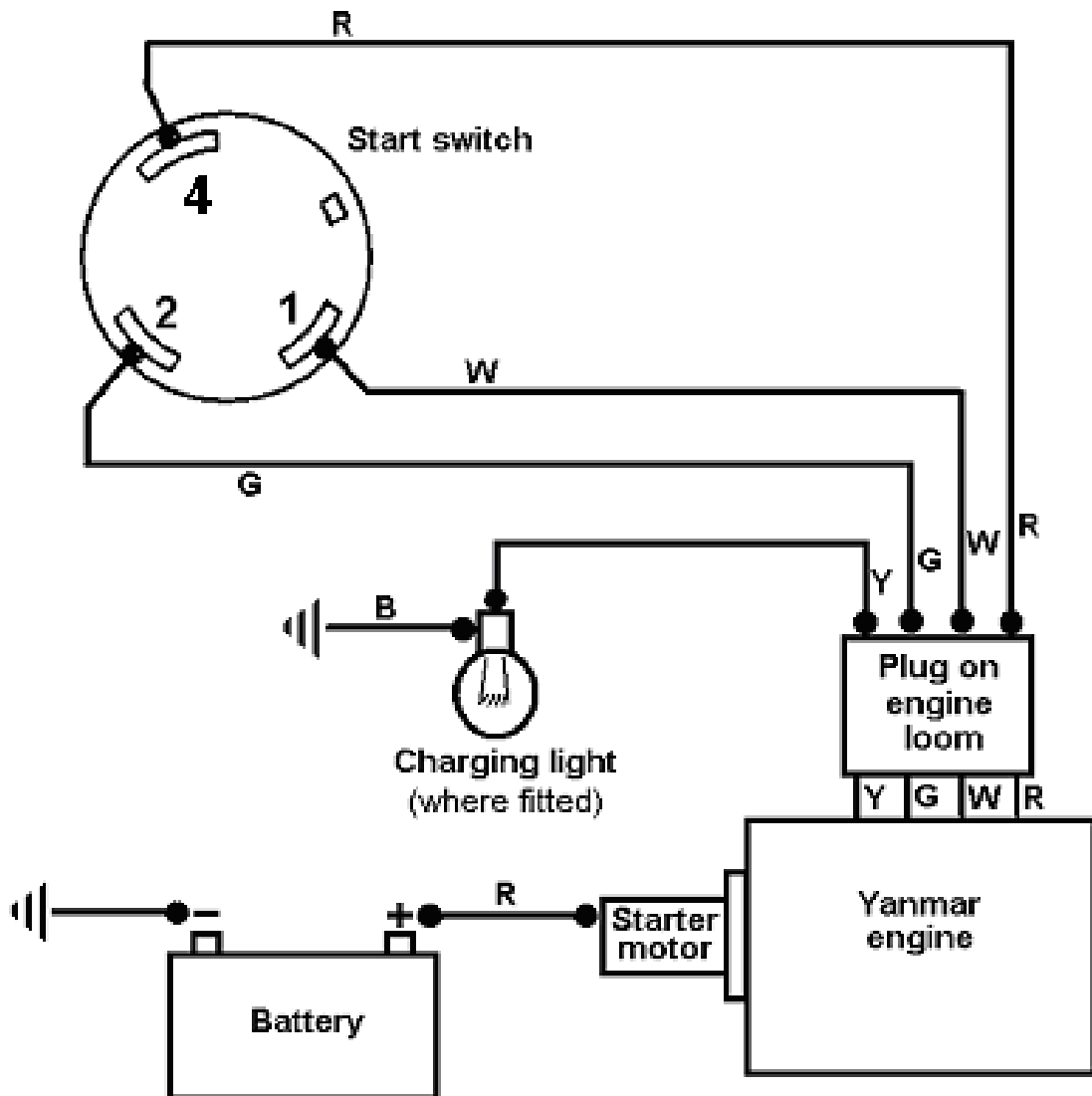

#### Wire colours

- R Red
- B Black
- G Green
- W White
- Y Yellow

#### NOTE: Wire identification

The red wire to the battery is much thicker than the red wire to the start switch.



# YANMAR L40 ARE-SE WIRING DIAGRAM

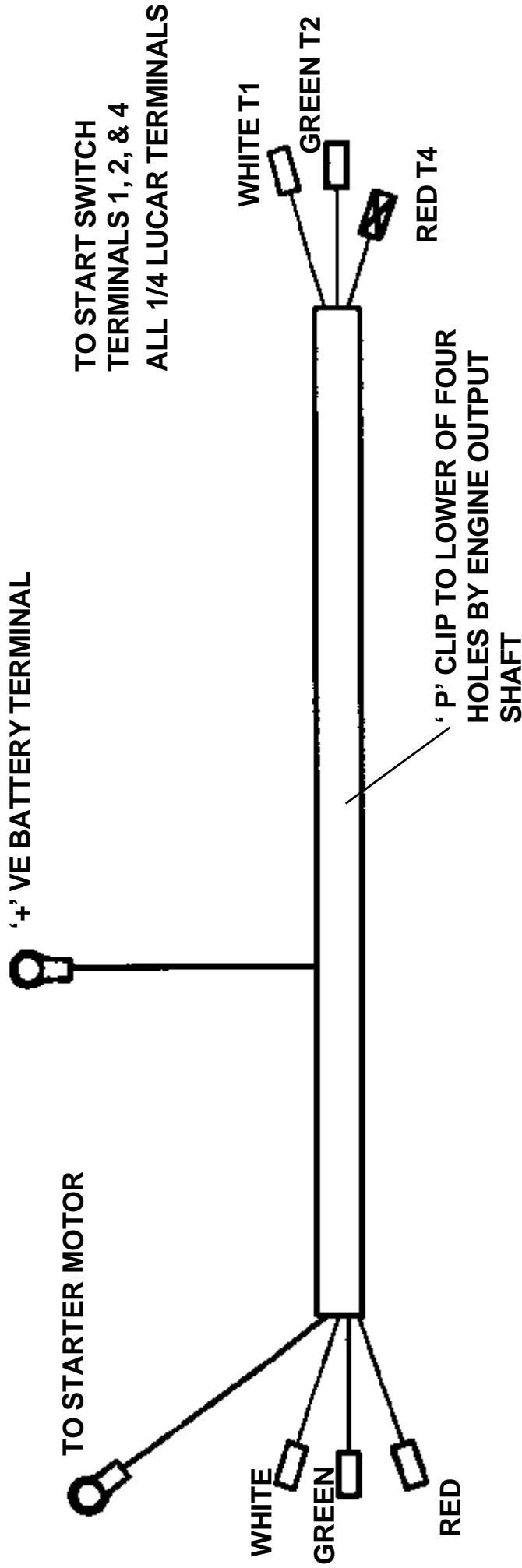

FOUR WAY PLUG TO REAR OF ENGINE BELOW IN-LINE FUSE ADJACENT TO REGULATOR

RED	GREEN
YELLOW	WHITE

# **WORKSHOP MANUAL**

**200T**

## **SECTION 7**

### **NOISE LEVELS**

## SECTION 7

### NOISE LEVELS

Noise Tests were carried out in accordance with EC Directive 79/113 on a 10 metre Hemisphere with the drum empty and rotating and in accordance with EC Directive 2000/14/EC again on a 10 metre hemisphere with the drum loaded and rotating.

Operators Ear Tests were carried out at a distance 1 metre from the Drum and Handwheel at a height of 1 metre.

#### Lister Petter LT1/LV1-10 Standard Build (79/113)

10 metre	101Lwa
----------	--------

Operators Ear	83Lpa
---------------	-------

#### Lister Petter LT1/LV1-10 Standard Build (2000/14/EC)

10 metre	102Lwa
----------	--------

Operators Ear	83Lpa
---------------	-------

#### Yanmar L40/L48 ARE-SE Standard Build (2000/14/EC)

10 metre	101Lwa
----------	--------

Operators Ear	80Lpa
---------------	-------

#### 240 Volt Electric Motor (79/113)

10 metre	98Lwa
----------	-------

Operators Ear	80Lpa
---------------	-------

# **WORKSHOP MANUAL**

**200T**

## **SECTION 8 SPECIAL TOOLS**

## 200T SPECIAL TOOLS

---

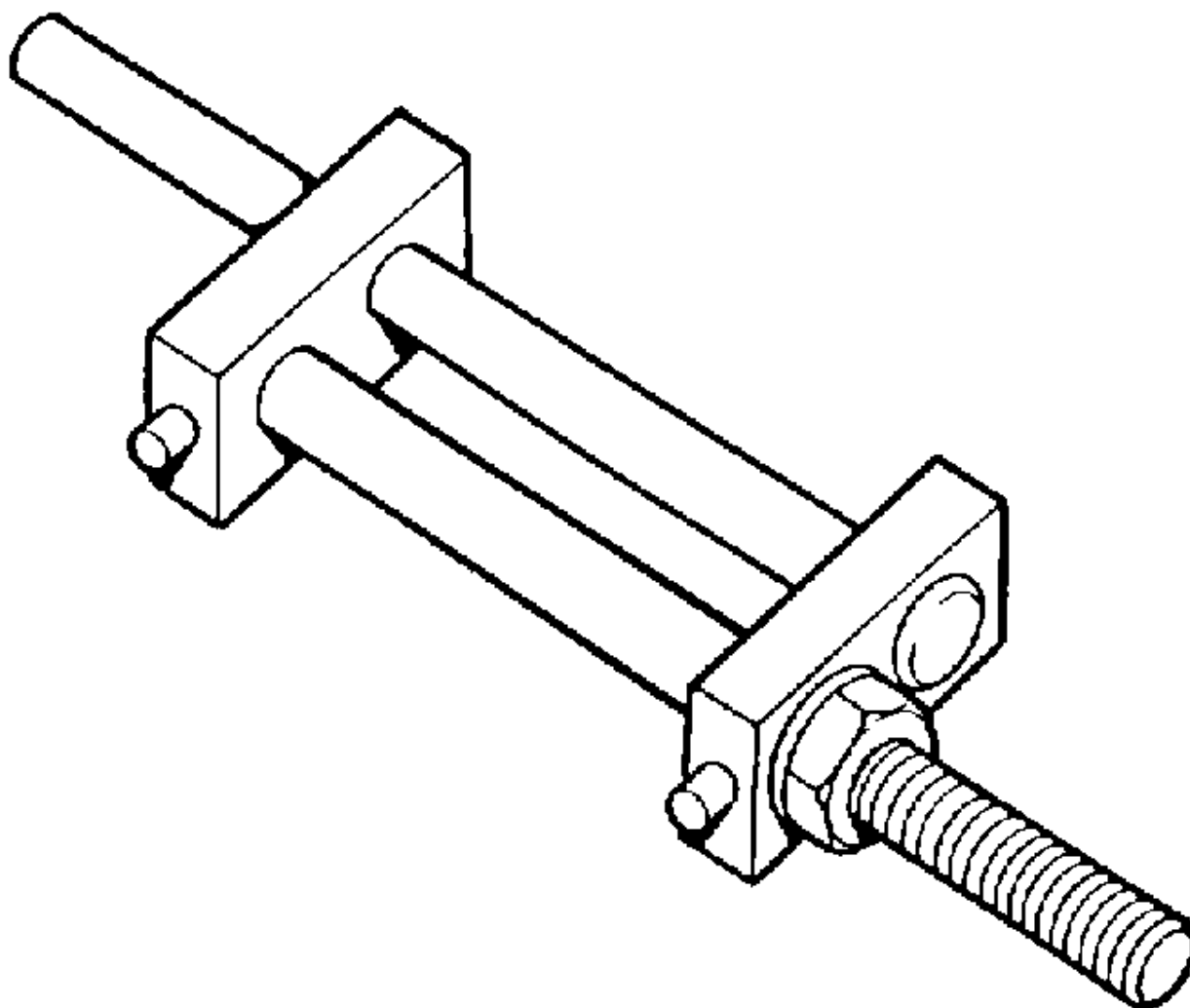

**513204000 DRUM CLIP TOOL**

---

# 200T SPECIAL TOOLS

1	513204000	CLAMP-DRUM CLIP	1
---	-----------	-----------------	---

# **WORKSHOP MANUAL**

**200T**

## **SECTION 9**

### **PARTS LISTING**

# 200T MAINFRAME AND FRONT AXLE

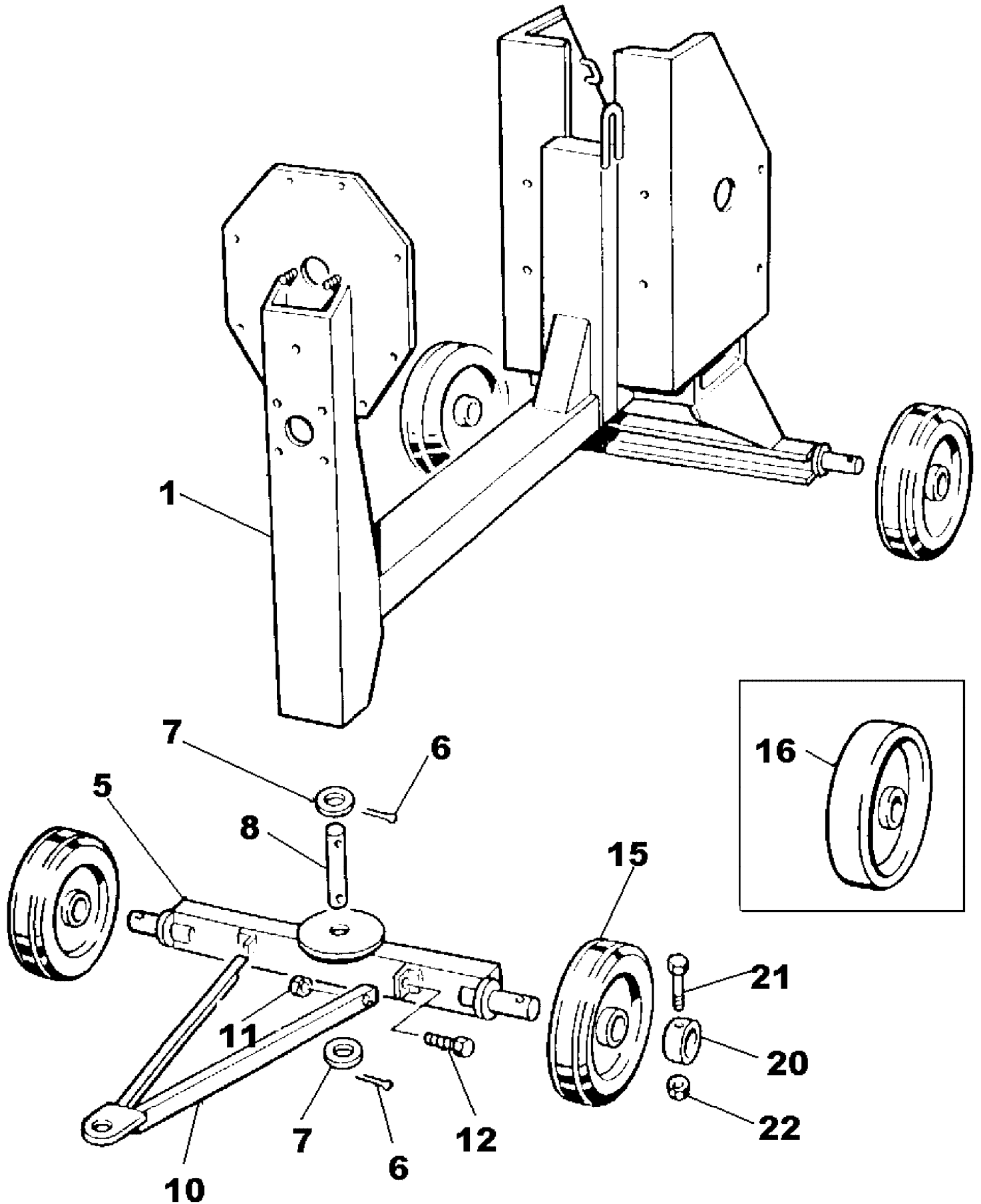



## 200T MAINFRAME AND FRONT AXLE

1	513357100	MAINFRAME	1
5	513324900	AXLE FRONT	1
6	353308200	PIN SPLIT	2
7	10S31	WASHER FLAT	2
8	513315100	PIN SWIVEL	1
10	513315200	BAR TOWING	1
11	61S05	NUT BINX	2
12	11S05D	SCREW SET	2
15	475115000	WHEEL SOLID	4
16	513198500	WHEEL STEEL	4
20	513324700	COLLAR	4
21	8S02H	BOLT	4
22	61S02	NUT BINX	4

# 200T SHEETMETAL AND PANELS

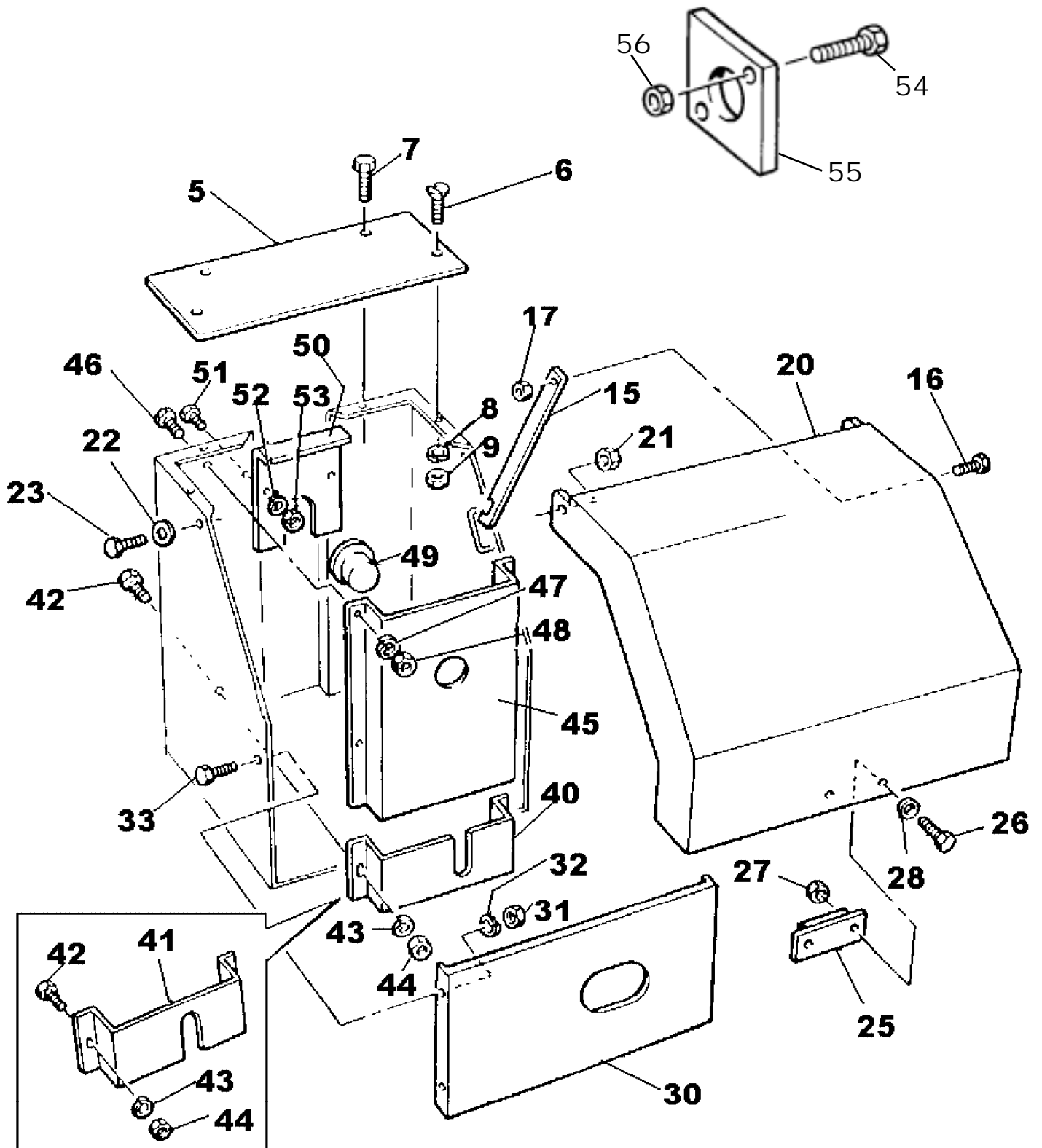

## 200T PANELS

5	513326000	PLATE TOP	1
6	52S02C	SCREW SET COUNTERSUNK HEAD	2
7	11S03A	SCREW SET	2
8	17S03	WASHER SPRING	2
8A	17S04	WASHER SPRING	2
9	7S02	NUT	2
9A	7S03	NUT	2
15	513325800	STRUT COVER	1
16	11S03D	SCREW SET	1
17	61S03	NUT BINX	1
20	513325500	COVER ENGINE/MOTOR	1
21	7S04	NUT	2
22	267S06	WASHER FLAT	2
23	11S04E	SCREW SET	2
25	513205300	STOP LID	1
26	11S02A	SCREW SET	2
27	61S02	NUT BINX	2
28	267S04	WASHER FLAT	2
30	513325400	PLATE CLOSING	1
31	7S03	NUT	4
32	17S04	WASHER SPRING	4
33	11S03A	SCREW SET	4
40	513266900	GUARD SPROCKET DIESEL	1
41	513336100	GUARD SPROCKET ELECTRIC	1
42	11S04B	SCREW SET	2
43	17S05	WASHER SPRING	2
44	7S04	NUT	2
45	513248700	GUARD CHAIN/BELT	1
46	11S04B	SCREW SET	4
47	17S05	WASHER SPRING	4
48	7S04	NUT	4
49	241859000	PLUG	1
50	513354600	PLATE CLOSING	1
51	11S02A	SCREW SET	2
52	17S03	WASHER SPRING	2
53	7S02	NUT	2
54	11S02C	SCREW SET	2
55	513362600	PLATE, ROPE GUIDE, YANMAR	1
56	61S02	NUT BINX	2

# 200T DRUM ASSEMBLY

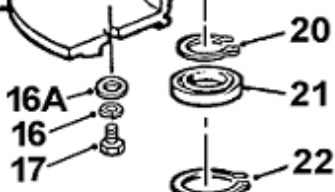
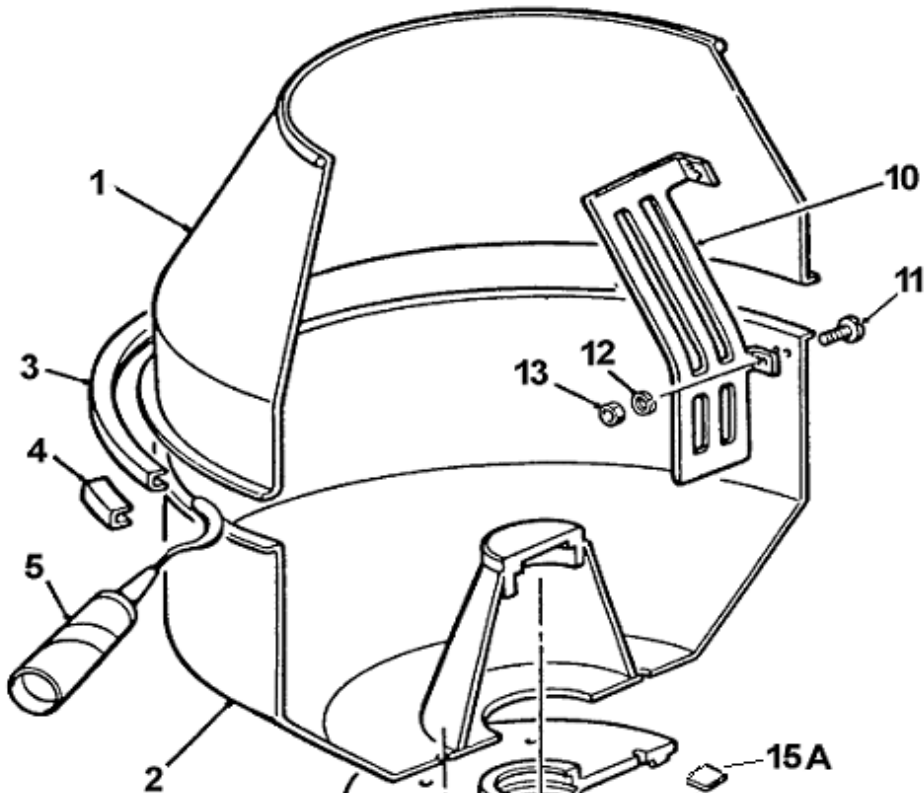

CAREFULLY REMOVE THE RUBBER SEALS FROM THE DRUM BEARINGS, PACK WITH GREASE THEN REFIT SEALS.

INSTALL THE DRUM SHAFT AND BEVEL GEAR INTO DRUM BASE AND FINGER TIGHTEN THE RETAINING SCREWS, ITEM 17.  
 CHECK THE GAP BETWEEN THE EDGE OF THE BEVEL THE GEAR AND DRUM (DUE TO MANUFACTURING TOLERANCES). INSTALL SHIMS ITEM 15A OF VARYING THICKNESS AS NECESSARY EQUISPACED AROUND THE CIRCUMFERENCE OF THE BEVEL GEAR IN 6/8 POSITIONS. THIS WILL ENSURE THAT WHEN THE RETAINING SCREWS ARE TIGHTENED THE CAST BEVEL GEAR WILL NOT BE DISTORTED. SEAL ROUND THE GEAR/DRUM CIRCUMFERENCE USING A SUITABLE FLEXIBLE SEALER

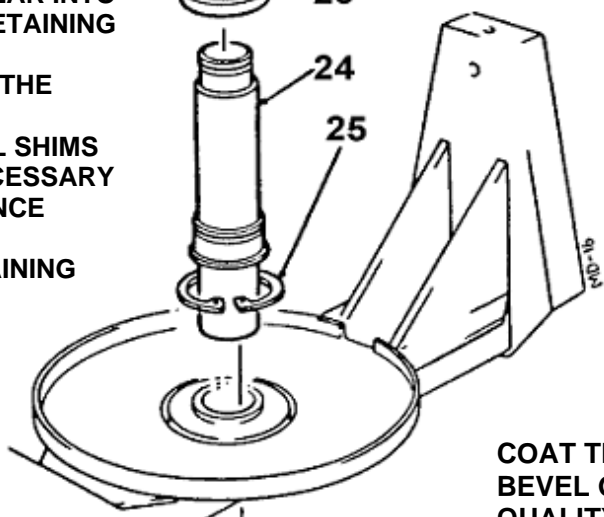

COAT THE TEETH OF THE BEVEL GEAR WITH A GOOD QUALITY OPEN GEAR FLUID BEFORE ASSEMBLING THE DRUM INTO THE TRUNNION.

COAT THE DRUM SHAFT AND BORES OF THE TRUNNION WITH ANTI SIEZE COMPOUND (COPPER GREASE) BEFORE ASSEMBLING INTO THE TRUNNION

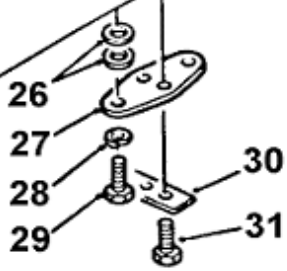

# 200T DRUM ASSEMBLY

---

1	513323902	DRUM TOP	1
2	513324000	DRUM BASE	1
3	513324100	CLIP DRUM	1
4	513324200	BRIDGE PIECE	1
5	V2000772	ADHESIVE FLEXIBLE	1
10	513324300	DRUM BLADE	2
11	16S09D	SCREW SLOTTED	8
12	17S05	WASHER SPRING	8
13	7S04	NUT	8
15	513305200	GEAR BEVEL	1
15A	513371203	SHIM, 2 MM THICK	A/R
15B	513371202	SHIM, 1.0MM THICK	A/R
15C	513371201	SHIM, 0.5MM THICK	A/R
16	17S06	WASHER SPRING	6
16A	267S07	WASHER FLAT	6
17	11S05D	SCREW SET	6
20	132760000	CIRCLIP	1
21	88S42D	BEARING	1
22	132775000	CIRCLIP	1
23	88S45D	BEARING	1
24	513310100	SHAFT DRUM	1
25	132313000	CIRCLIP	1
26	267S09	WASHER FLAT, HEAVY GAUGE 3MM THICK	A/R
26A	267S20	WASHER FLAT, LIGHT GAUGE, 2MM THICK	A/R
26B		SHIM, WASHER 1.0MM THICK	A/R
26C		SHIM WASHER 0.5MM THICK	A/R
27	513310600	PLATE, RETAINING	1
28	17S08	WASHER SPRING	2
29	11S06H	SCREW SET	2
30	513326300	WASHER LOCKING STOP	1
31	11S06E	SCREW SET	2

# 200T TRUNNION AND TILT WHEEL

COAT LOCKING PLUNGER ITEM 27 AND BORE OF ITEM 22 LIBERALLY WITH COPPERSLIP ON ASSEMBLY

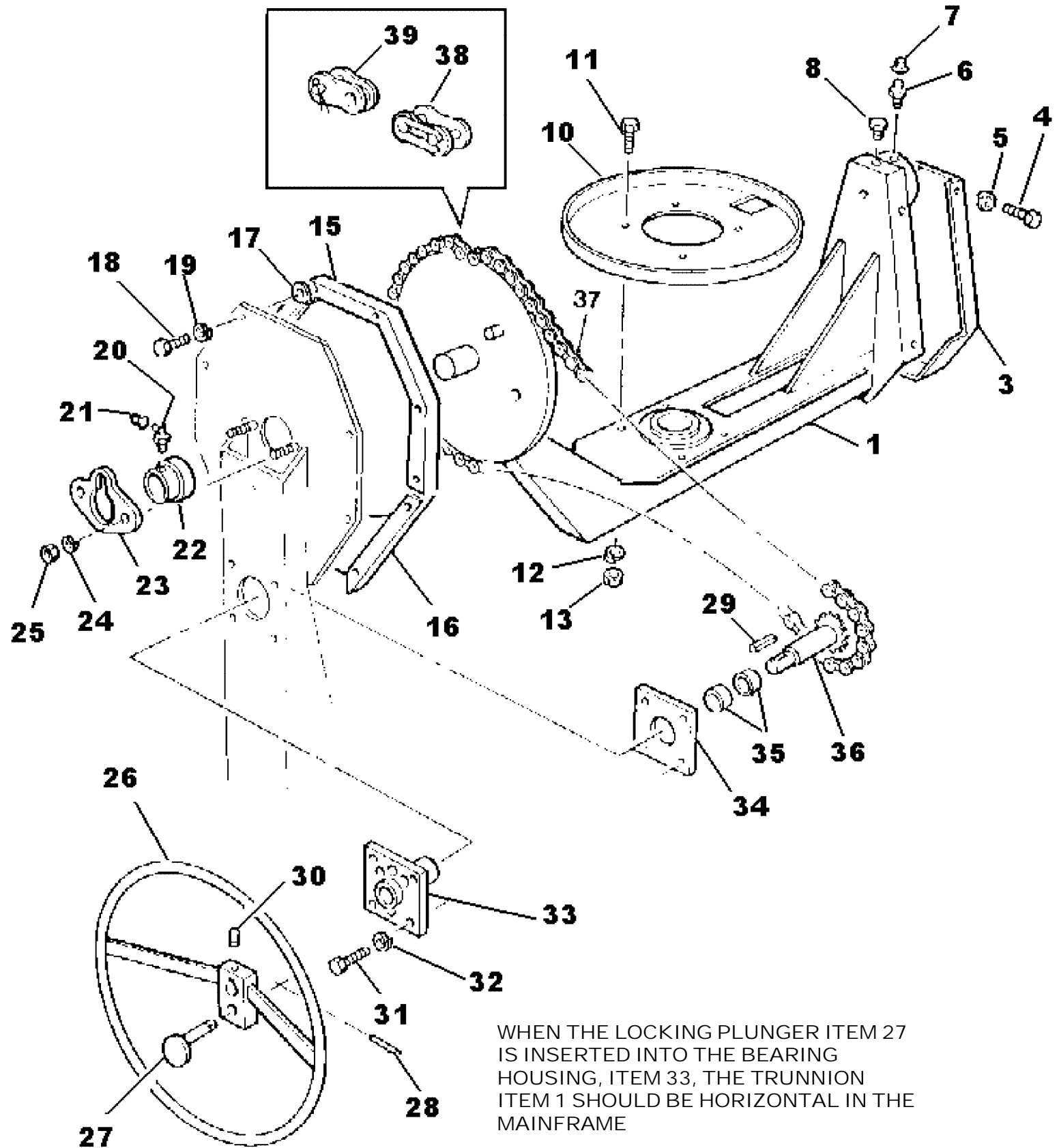

## 200T TRUNNION + TILT WHEEL

1	513354000	TRUNNION	1
3	513316600	COVER REAR CHAIN	1
4	11S02AA	SCREW SET	4
5	17S03	WASHER SPRING	4
6	131S01	NIPPLE GREASE	1
7	176S01	CAP NIPPLE	1
8	315803100	GREASE PLUG	1
10	513316500	GUARD DRUM GEAR	1
11	11S03B	SCREW SET	4
12	17S04	WASHER SPRING	4
13	7S03	NUT	4
15	513316300	GUARD-UPPER	1
16	513316400	GUARD-LOWER	1
17	332719000	NUT SPIRE	10
18	11S02C	SCREW SET	10
19	17S03	WASHER SPRING	10
20	131S02	NIPPLE GREASE 90°	1
21	176S01	CAP NIPPLE	1
22	513323700	INSERT	1
23	513323800	PLATE	1
24	17S06	WASHER SPRING	2
25	7S05	NUT	2
26	513315400	WHEEL TILT	1
27	513194400	PLUNGER LOCKING	1
28	54S01A	PIN ROLL	1
29	304710840	KEY RECT FEATHER	1
30	57S06F1	SCREW GRUB	1
31	11S04E	SCREW SET	4
32	17S05	WASHER SPRING	4
33	513315600	BEARING-TILT WHEEL	1
34	513315900	PLATE	1
35	112803400	BUSH	2
36	513316000	SHAFT TILT WHEEL	1
37	134105107	CHAIN TILT WHEEL	1
38	134105002	LINK CONNECTING	1
39	134105001	LINK HALF	A/R

# 200T DRUM DRIVE

**SPROCKETS 32 AND 20 MUST BE ALIGNED ON ASSEMBLY, ADJUST POSITION OF ITEM 20 ON BEVEL PINION SHAFT, ITEM 5**

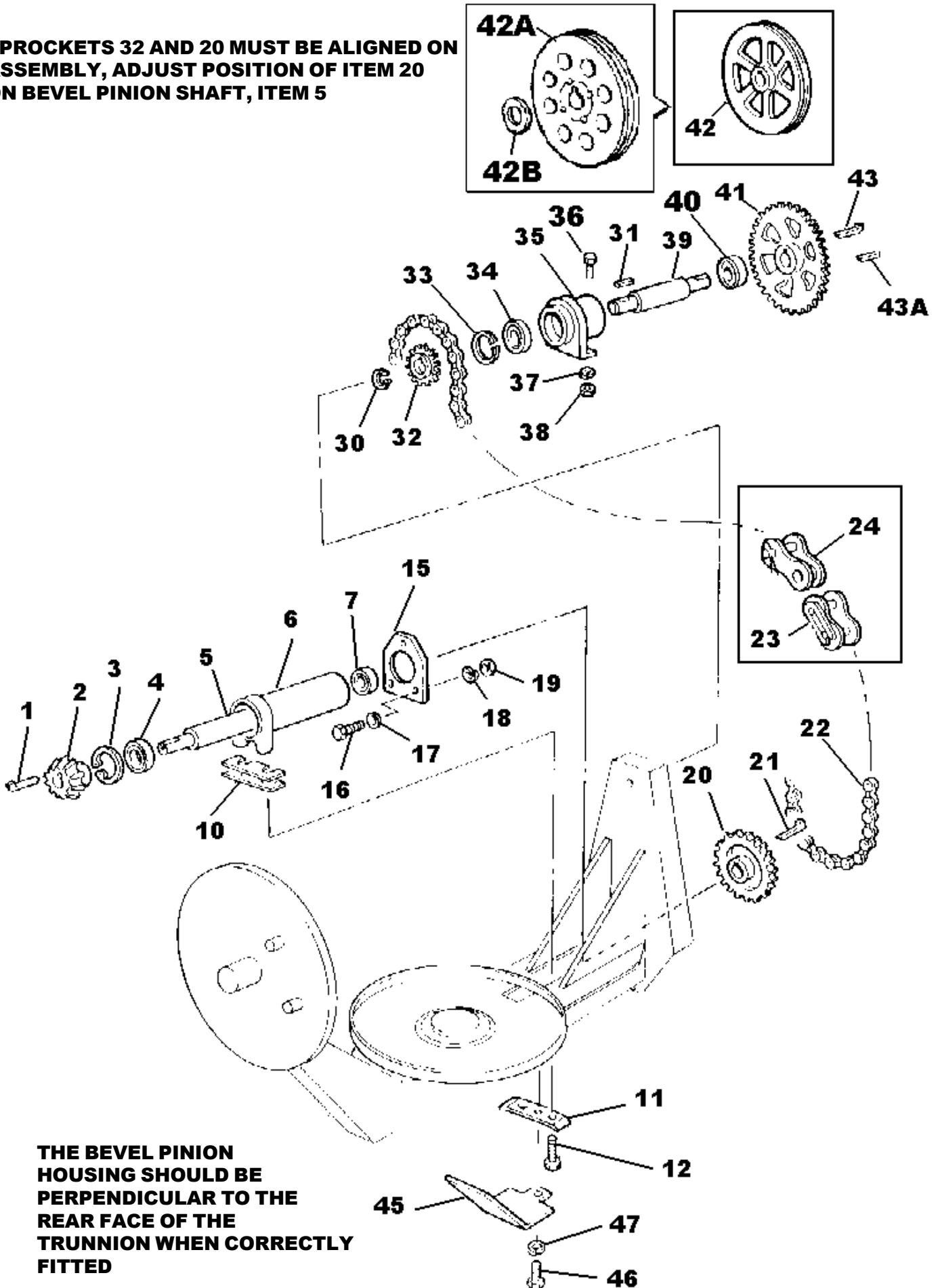

**THE BEVEL PINION HOUSING SHOULD BE PERPENDICULAR TO THE REAR FACE OF THE TRUNNION WHEN CORRECTLY FITTED**



## 200T DRUM DRIVE

1	300110845	KEY TAPER GIB HEAD	1
2	513310700	PINION	1
3	132362000	CIRCLIP	1
4	88S05D	BEARING	1
5	513310300	SHAFT	1
6	513305400	HOUSING	1
7	88S15D	BEARING	1
10	513152400	SHIM PACK	1 SET
11	513324400	WASHER LOCK STRIP	1
12	11S05H	SCREW SET	2
15	513298900	PLATE	1
16	11S04C	SCREW SET	2
17	267S06	WASHER FLAT	2
18	17S05	WASHER SPRING	2
19	7S04	NUT	2
20	513305300	SPROCKET	1
21	300110845	KEY TAPER GIB	1
22	134105070	CHAIN	1
23	134105002	LINK CONNECTING	A/R
24	134105001	LINK HALF	A/R
30	132725000	CIRCLIP	1
31	304708035	KEY FEATHER	1
32	513310500	SPROCKET	1
33	132362000	CIRCLIP	1
34	88S05D	BEARING	1
35	513305500	HOUSING	1
36	11S05F	SCREW SET	2
36A	267S07	WASHER FLAT	2
37	17S06	WASHER SPRING	2
38	7S05	NUT	2
39	513310400	SHAFT COUNTER	1
40	88S15D	BEARING	1
41	513310800	SPROCKET LISTER ENGINE	1
42	513331800	PULLEY 240 VOLT ELECTRIC MOTOR	1
42A	371123000	PULLEY C/W BUSH YANMAR ENGINE	1
42B	267S12	WASHER FLAT FIT BEHIND ITEM 42B ON SHAFT	1
43	300110845	KEY TAPER GIB HEAD LISTER & ELECTRIC 240V	1
43A	CR329047	KEY PARALLEL USE WITH YANMAR PULLEY	1
45	513211800	GUARD BEVEL PINION	1
46	66S03AA	SCREW SET	1
47	41S05	WASHER SPRING	1

# 200T LISTER-PETTER LT1/LV1 BUILD 10

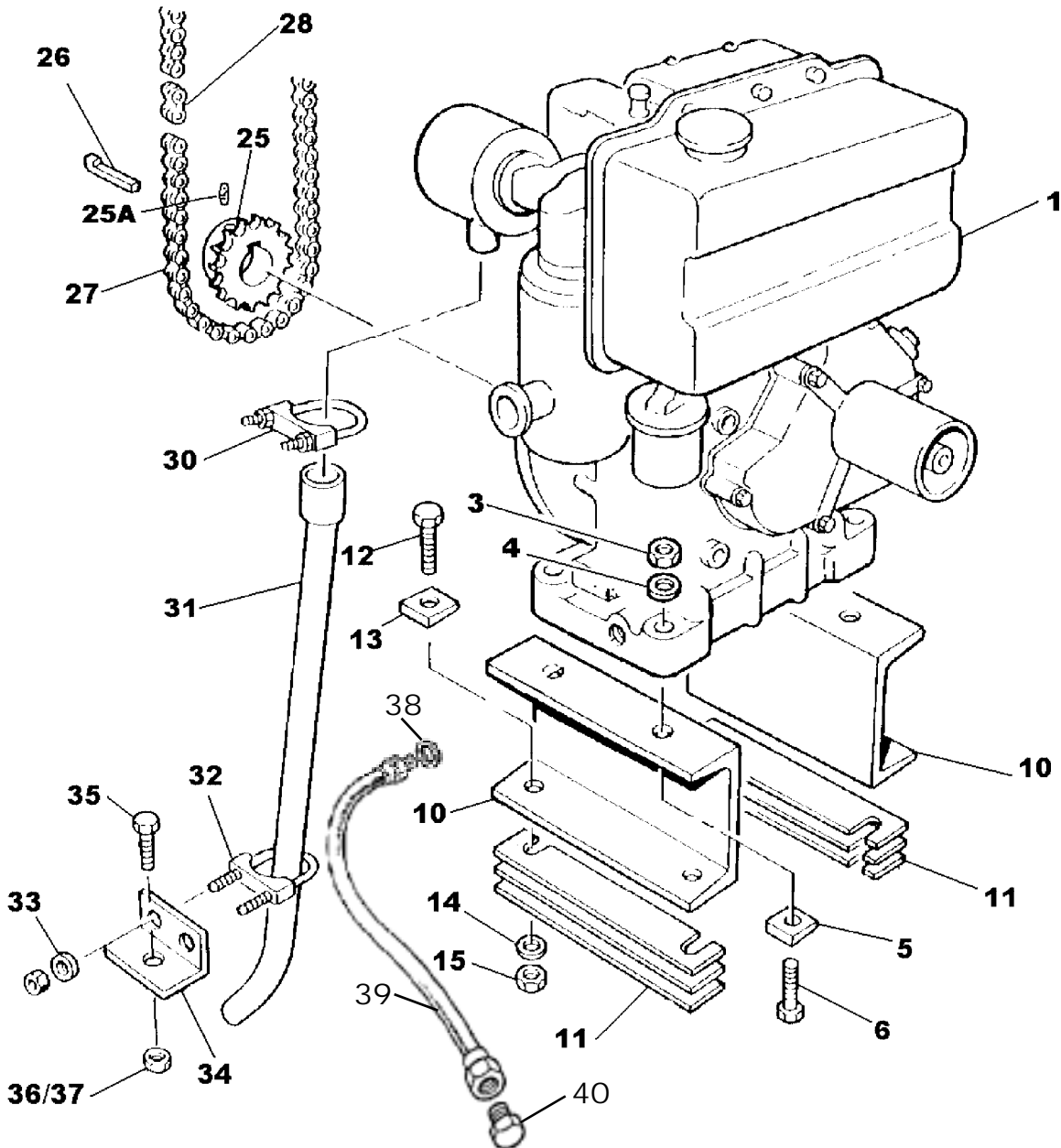
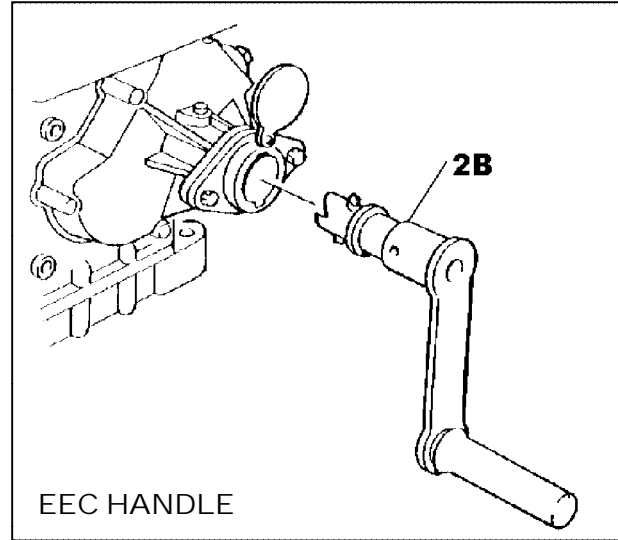
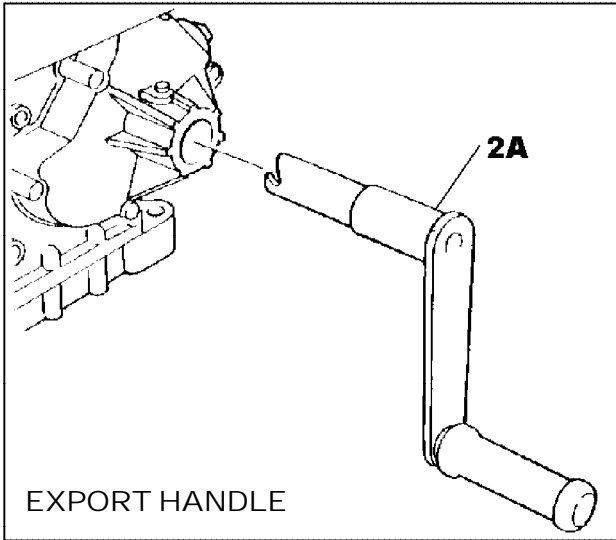

## 200T LISTER-PETTER LT1/LV1-10

1	354051000 (WITHOUT ANTI KICKBACK)	ENGINE LT1/LV1-10 (EXPORT)	1
1A	354054100 (WITH ANTI KICKBACK)	LT1/LV1-10 LKB UK/EEC (ANTI KICKBACK)	1
2A		EXPORT NON ANTI KICKBACK HANDLE	
2B		UK-EEC ANTI KICKBACK HANDLE	
3	61S05	NUT BINX	4
4	267S07	WASHER FLAT	4
5	105S05	WASHER TAPERED	4
6	8S05J	BOLT	4
10	513267400	CHANNEL ENG MOUNT	2
11	513248400	SHIMS (SET)	1
12	8S05E	BOLT	4
13	105S05	WASHER TAPERED	4
14	267S07	WASHER FLAT	4
15	61S05	NUT BINX	4
25	513326400	SPROCKET	1
25A	57S05D2	SCREW GRUB	1
26	300204160	KEY	1
27	134105095	CHAIN	1
28	134105002	LINK CONNECTING	1
-	134105001	LINK HALF (NOT ILLUSTRATED)	1
30	354051005	CLAMP EXHAUST	1
31	513267500	PIPE EXHAUST	1
32	153S01	CLAMP EXHAUST	1
33	267S04	WASHER FLAT	2
34	513337900	BRACKET	1
35	11S04B	SCREW SET	1
36	17S05	WASHER SRPING	1
37	7S04	NUT	1
38	100S04	SEAL BONDED	1
39	513362800	OIL DRAIN HOSE	1
40	127S04	PLUG, OIL DRAIN	1

# 200T YANMAR L40/L48 ARE-SE ENGINE

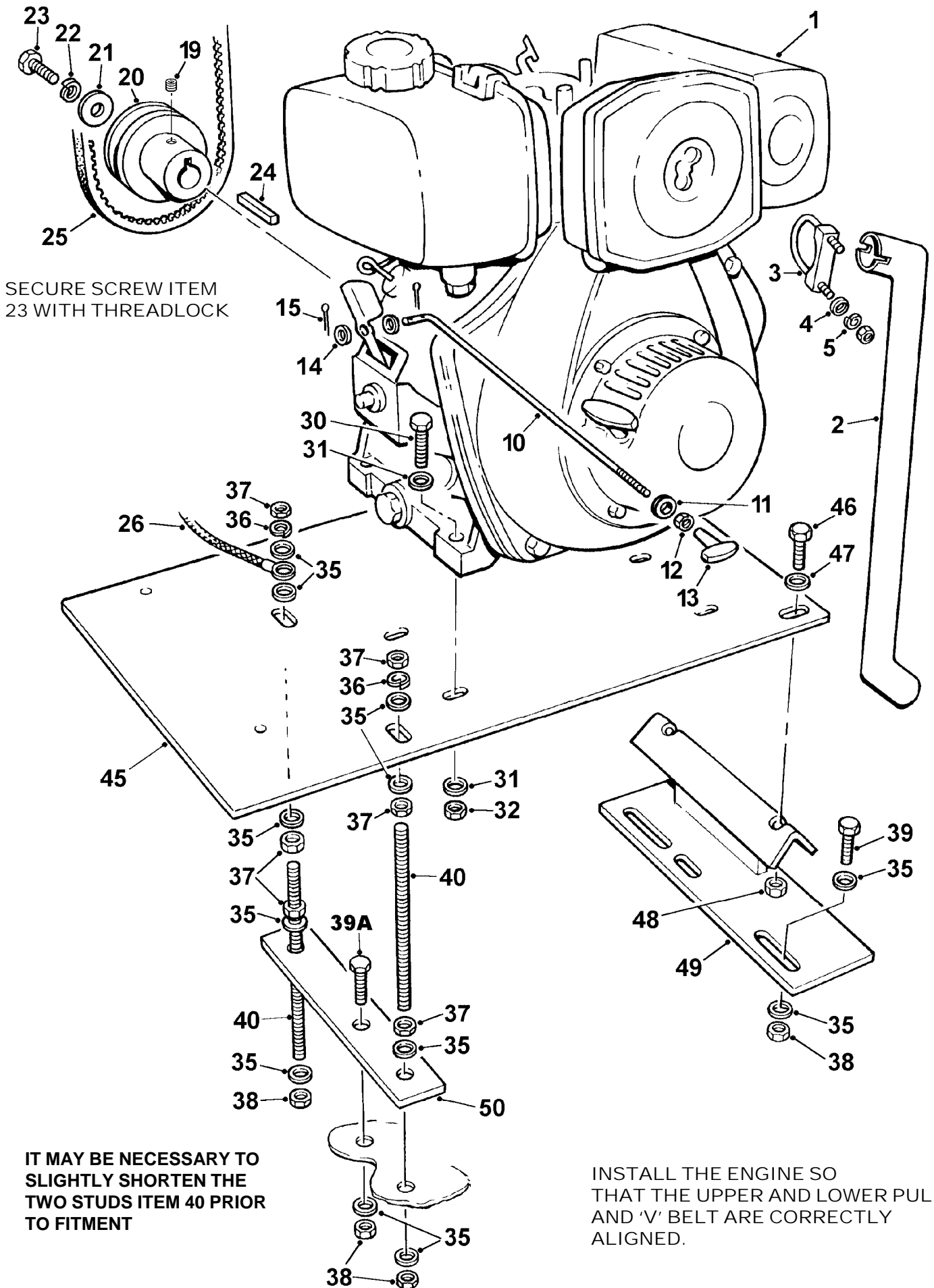

SECURE SCREW ITEM 23 WITH THREADLOCK

IT MAY BE NECESSARY TO SLIGHTLY SHORTEN THE TWO STUDS ITEM 40 PRIOR TO FITMENT

INSTALL THE ENGINE SO THAT THE UPPER AND LOWER PULLIES AND 'V' BELT ARE CORRECTLY ALIGNED.

# 200T YANMAR L40/L48 ARE-SE ENGINE

1	V2005210	ENGINE, YANMAR L40/L48 ARE-SE	1
2	513361600	PIPE EXHAUST	1
3	153S02	CLAMP EXHAUST	1
4	267S04	WASHER FLAT	2
5	17S03	WASHER SPRING	2
10	513362300	ROD ENGINE STOP	1
11	254820000	GROMMET, OPEN, FITTED IN CLOSING PLATE	1
12	7S02	NUT	1
13	V2005213	HANDLE 'T' ENGINE STOP	1
14	267S04	WASHER FLAT	2
15	44S02B	PIN, SPLIT	2
19	57S04D2	SCREW GRUB M6	1
20	V2005220	PULLEY	1
21	V2004220	WASHER SPECIAL	1
22	17S04	WASHER SPRING	1
23	11S03D	SCREW SET	1
24	305110550	KEY PARALLEL	1
25	397400500	BELT 'V'	1
26	V2005211	CABLE, NEGATIVE EARTH	1
30	8S03D	BOLT	4
31	267S05	WASHER FLAT	8
32	61S03	NUT BINX	4
35	267S07	WASHER FLAT	14
36	17S06	WASHER SPRING	2
37	7S05	NUT	6
38	61S05	NUT BINX	5
39	11S05D	SCREW SET	2
39A	11S05G	SCREW SET	1
40	513333100	STUD, CUT TO LENGTH	2
45	513361800	PLATE, ENGINE MOUNTING	1
46	8S04D	BOLT	2
47	267S06	WASHER FLAT	2
48	61S04	NUT BINX	2
49	513358800	SUPPORT BRACKET	1
50	513362500	BAR ENGINE MOUNT	1

# 200T YANMAR ELECTRICAL SYSTEM

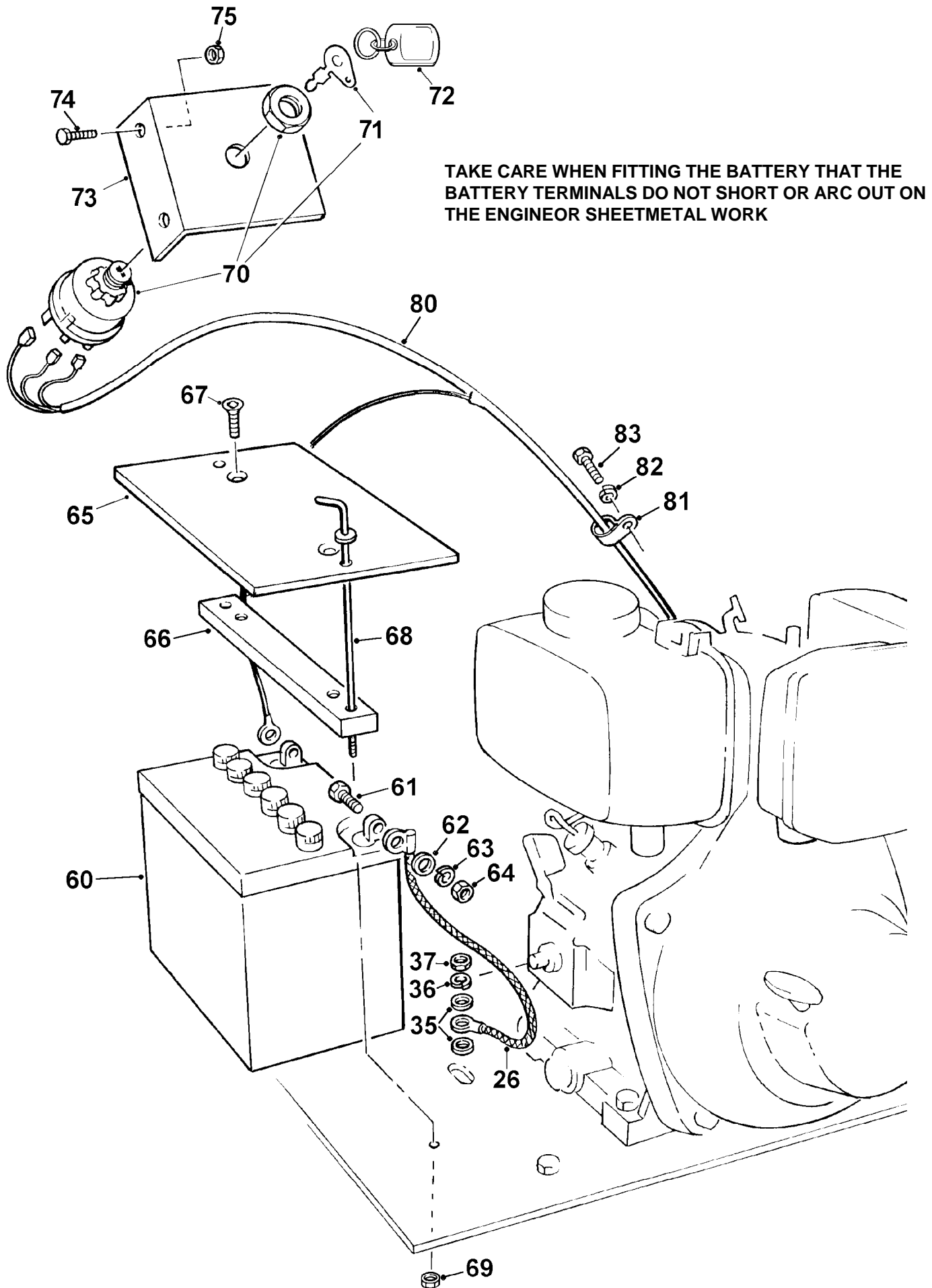

# 200T YANMAR ELECTRICAL SYSTEM

26	V2005211	CABLE, NEGATIVE EARTH	1
35	267S07	WASHER FLAT	2
36	17S06	WASHER SPRING	1
37	7S05	NUT	1
60	109S11	BATTERY 12 VOLT	1
61	11S02B	SCREW SET	1
62	267S04	WASHER FLAT	1
63	17S03	WASHER SPRING	1
64	7S02	NUT	1
65	513362000	COVER BATTERY	1
66	513361900	CLAMP BATTERY	1
67	52S02E	SCREW COUNTERSUNK	2
68	513361700	ROD BATTERY CLAMP	2
69	61S02	NUT BINX	2
70	V2003561	SWITCH START C/W KEY	1
71	V601179	KEY,SUPPLIED WITH SWITCH	1
72	V2003540	RING KEY	1
73	513359200	BRACKET SWITCH START	1
73A	V2005218	DECAL SWITCH START	1
74	11S03A	SCREW SET	2
75	61S03	NUT BINX	2
80	513362200	LOOM WIRING	1
81	V2005209	CLIP 'P'	1
82	17S04	WASHER SPRING	1
83	1103A	SCREW SET	1

# 200T 240 VOLT ELECTRIC MOTOR

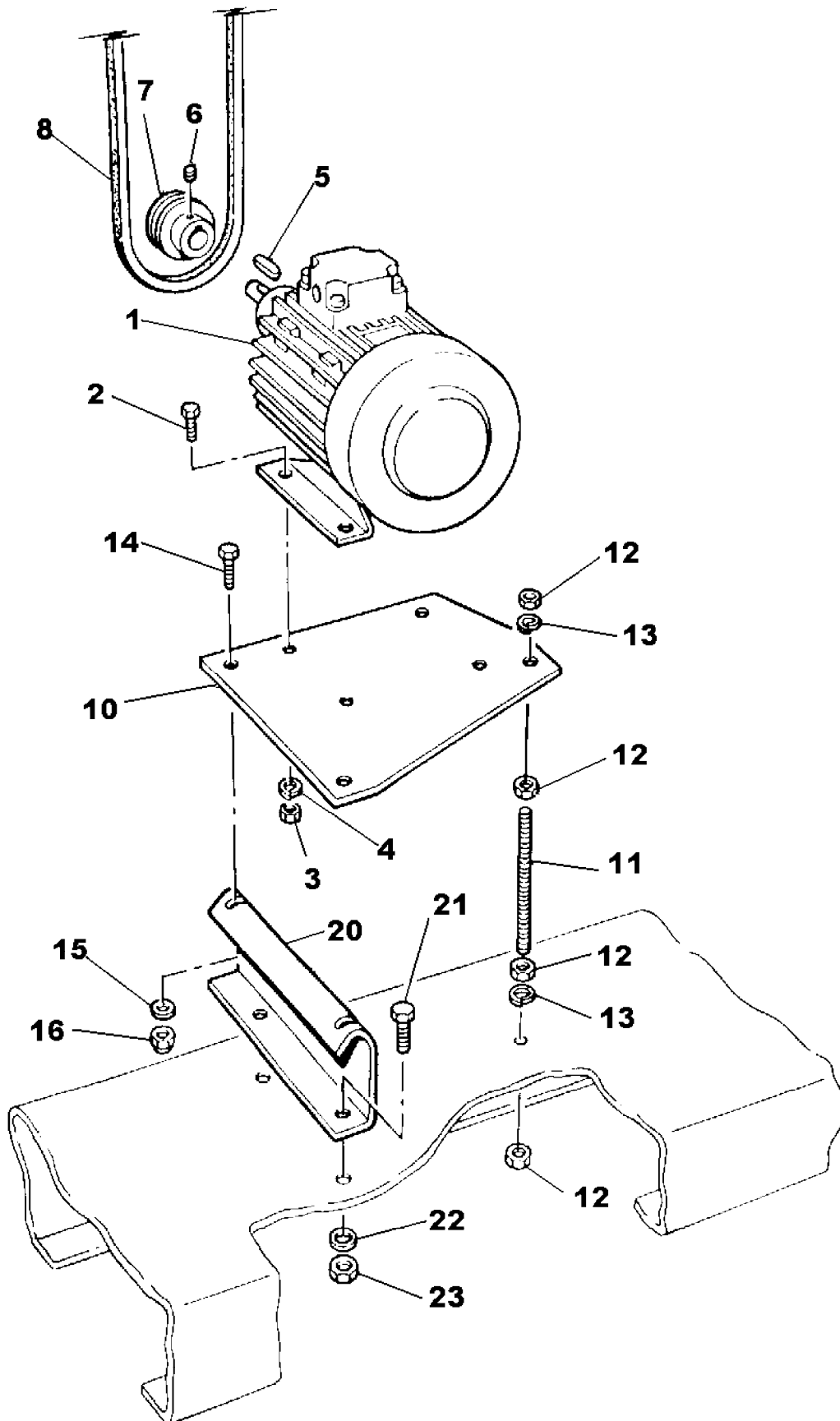



# 200T 240VOLT ELECTRIC MOTOR

1	202438000	MOTOR 240V	1
2	11S04D	SCREW SET	4
3	7S04	NUT	4
4	17S05	WASHER SPRING	4
5	304710840	KEY PARALLEL	1
6	57S04D2	SCREW GRUB	1
7	513333500	PULLEY VEE	1
8	397400100	BELT VEE	1
10	513335900	PLATE MOTOR MOUNTING	1
11	513333100	STUD	1
12	7S05	NUT	4
13	17S06	WASHER SPRING	2
14	8S05E	BOLT	2
15	267S07	WASHER FLAT	2
16	59S04	NUT NYLOC	2
20	5133396000	SUPPORT MOUNT	1
21	11S05D	SCREW SET	2
22	267S07	WASHER FLAT	2
23	59S04	NUT NYLOC	2

# 200T 240 VOLT START-STOP SWITCH

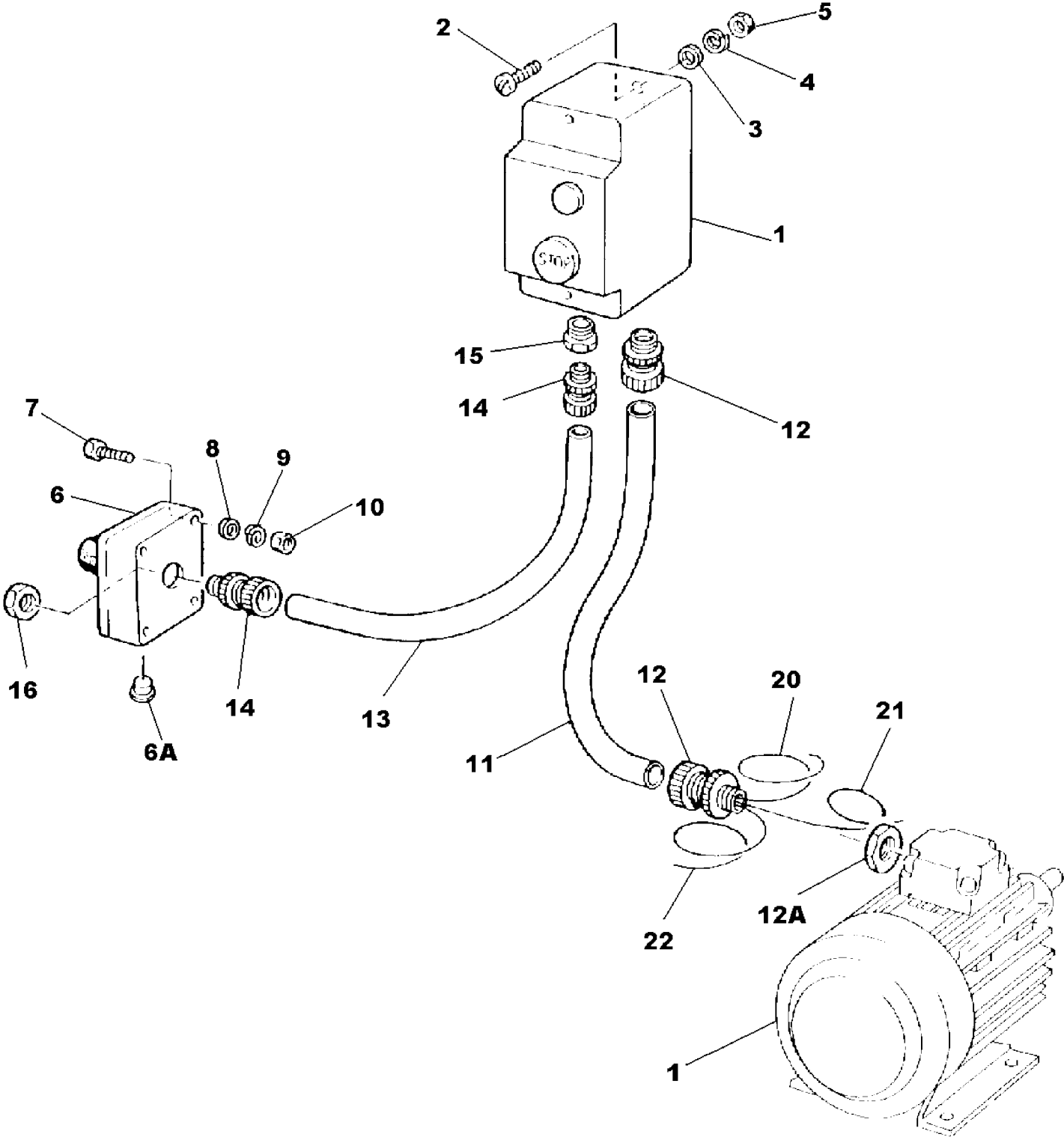

# 200T START/STOP SWITCHES-240 VOLT ELECTRIC

1	208392500	SWITCH-STARTER	1
-		OVERLOAD RELAY-SUPPLIED WITH STARTER	
2	16S06C	SCREW RD/HEAD	2
3	267S03	WASHER FLAT	2
4	17S02	WASHER SPRING	2
5	7S01	NUT	2
6	208880000	SWITCH STOP	1
7	11S01D	SCREW SET	2
8	267S03	WASHER FLAT	2
9	17S02	WASHER SPRING	2
10	7S01	NUT	2
11	131770010	TUBE CONDUIT 20MM	1MT
12	131271000	COUPLING 20MM	2
12A	56S07	NUT LOCK	1
13	131766010	TUBE CONDUIT 16MM	1MT
14	131270000	COUPLING 16MM	2
15	131570016	FITTING REDUCING	1
16	133266050	NUT LOCK	1
20	144797000	CABLE RED	2MT
21	144798000	CABLE BLACK	2MT
22	144799000	CABLE GREEN/YELLOW	2MT

# 200T DECALS AND LOGOS

1

# 200T

2

WINGET	
Model	
Serial no.	
Engine no.	Power output
Capacity	Weight kg.
SRO	Year of mark.

© 2004 Winget Group Company

3

**DANGER**  
KEEP ENGINE HOUSING  
LID CLOSED WHEN  
ENGINE IS RUNNING

4

**SAFETY WARNING**

- 1 Before starting this machine, the operator should be familiar with the operating instructions issued by the manufacturer.
- 2 The manufacturer's rated capacity must never be exceeded.
- 3 Before carrying out any maintenance, servicing, or greasing, always ensure that the engine has been switched off. Never work on a machine while it is running.

5

# WINGET

6



7



8



9



10



11

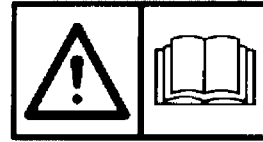

12

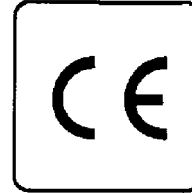

13



14

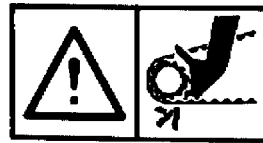

15

 **WHEN MACHINE UNATTENDED  
REMOVE STARTING HANDLE  
TO PREVENT UNAUTHORISED USE.**

16

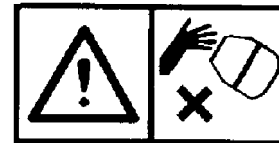

17

 **ENGINE STOP  
UNDER ENGINE  
COVER.**

18

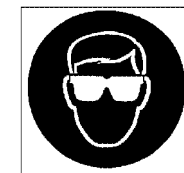

19



20

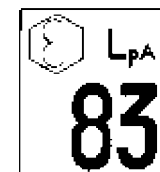

## 200T DECALS AND LOGO'S

---

1	V2003110	DECAL 200T	2
2	V2003037	PLATE SERIAL NUMBER	1
2A	101S05D	RIVET	4
3	504600900	DECAL ENGINE HOUSING	1
4	504694600	DECAL SAFETY	1
5	V2003039	DECAL WINGET	3
6	V2003038	DECAL STRIPE	2
7	V2003101	DECAL DIESEL	1
8	V2003665	DECAL LIFTING POINT	1
9	V2003598	DECAL BRITISH MADE	1
10	V2004307	DECAL ELECTRICAL HAZARD	2
11	V2004229	DECAL OPERATORS HANDBOOK	2
12	V2004223	DECAL CE MARK (ONLY FITTED TO EC SPEC MACHINES)	1
13	V2004282	DECAL HOT SURFACE	1
14	V2004281	DECAL ENTRAPMENT	1
15	V2004288	DECAL REMOVE STARTING HANDLE	1
16	V2004289	DECAL KEEP HANDS CLEAR	2
17	V2004302	DECAL ENGINE STOP	1
18	V2004744	DECAL EYE PROTECTION	1
19	V2004132	DECAL 102 LWA (LT1 DIESELS)	1
20	V2003574	DECAL 83 LPA (LT1 & YANMAR DIESELS)	1
21	V2004227	DECAL BATTERY ISOLATOR	1
22	V2004235	DECAL BATTERY NEGATIVE	1
23	V2005276	DECAL COLD START YANMAR L40 ARE SE	1
24	V2005214	DECAL YANMAR RECOIL	1
25	V2005218	DECAL START SWITCH YANMAR L40 ARE SE	1
26	V2005208	DECAL FOLLOW INSTRUCTIONS	1
27	V2005311	DECAL 101 LWA (YANMAR DIESELS)	1
28	V2004130	DECAL 80 LPA (240 VOLT ELECTRIC MOTOR)	1
29	V2004297	DECAL 98 LWA (240 VOLT ELECTRIC MOTOR)	1
30	V2005290	DECAL ENGINE STOP BUTTON YANMAR L40ARE SE	1
31	V2005291	DECAL TRANSPORTATION BY FORKLIFT	1

# 200T DECALS AND LOGOS

21



22

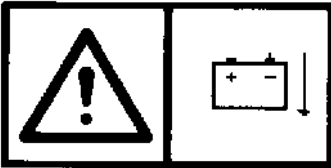

23

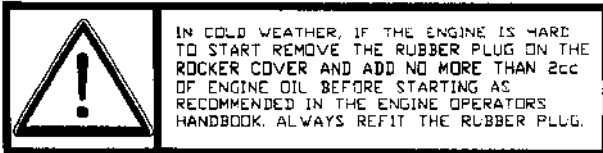

24

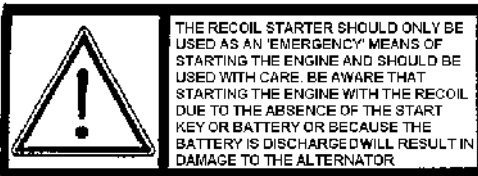

25

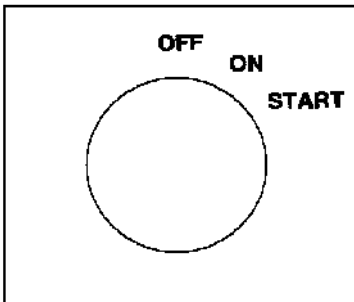

26

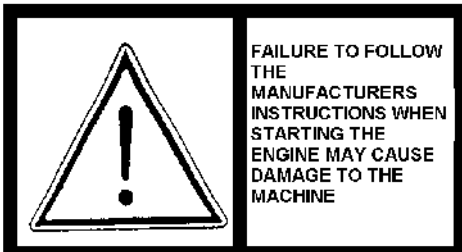

27

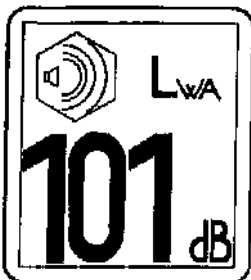

28

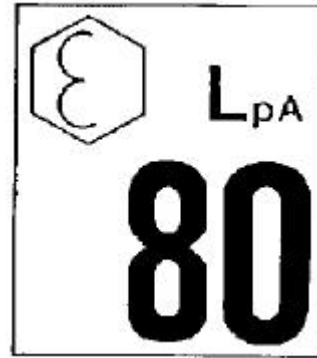

29

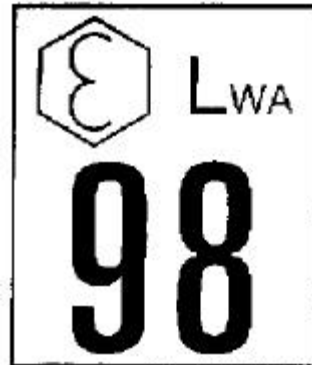

30



31

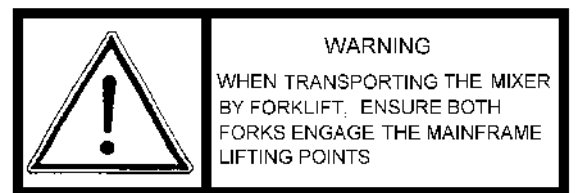

**INTENTIONALLY BLANK PAGE**

# CALIFORNIA

## Proposition 65 Warning

**Diesel engine exhaust and some of its constituents are known to the State of California to cause cancer, birth defects, and other reproductive harm**