

# DUMPER

# 2B1500

## HYDRAULIC STEERING

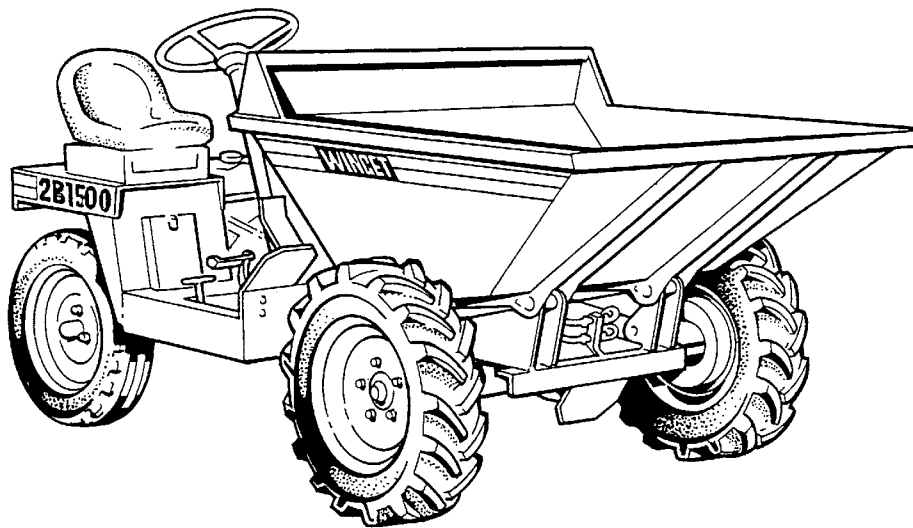

# OPERATORS HANDBOOK & PARTS

From Serial No: 1214

Issued April 2019

# WINGET

WINGET LIMITED, P.O. Box 41, Edgefold Industrial Estate, Plodder Lane, Bolton, BL4 0LR, England  
Tel: +44 (0) 1204 854650  
parts@winget.co.uk  
service@winget.co.uk  
www.winget.co.uk



# DUMPER

# 2B1500

## HYDRAULIC STEERING

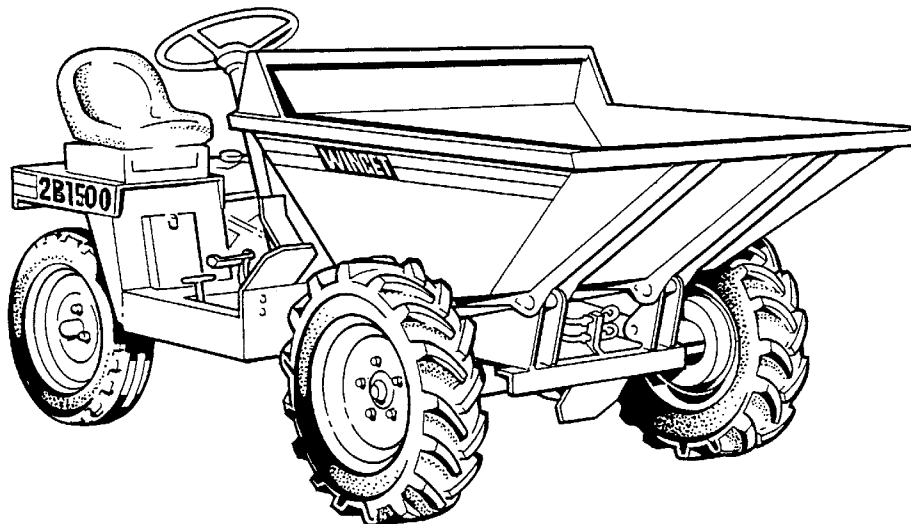

The contents of this Handbook, although correct at the time of publication, may be subject to alteration by the Manufacturers without prior notice.

Winget Limited operate a policy of continuous product development. Therefore, some illustrations or text within this publication may differ from your machine.

## CONTENTS

Section	Page	Section	Page
<b>INTRODUCTION</b>		<b>SERVICE</b>	
Contents	II	Service Safe Working	3.1
Introduction to the Handbook	III	Service schedule chart	3.2
Machine identification	III	Engine TR1	3.4
Warranty Terms and Conditions	IV	Lubrication oil and filter	3.4
		Fuel system	3.6
		Air cleaner	3.7
		Gearbox	3.8
		Front axle	3.9
		Wheels and tyres	3.10
		Battery	3.11
		Steering Valve	3.12
		Greasing	3.13
		Hydraulic system	3.14
		Braking system	3.18
<b>SAFE WORKING</b>		<b>TECHNICAL INFORMATION</b>	
Machine modification	1.1	Dimensions	4.1
Training	1.1	Specifications	4.2
Running-in	1.1	<i>Road speeds</i>	
Driving	1.1	<i>Lubricants and fluids</i>	
Skips and loading	1.3	<i>General Dumper specifications</i>	
Towing	1.3	<i>Capacities – fluids</i>	
Gradients	1.3	<i>Adjustments</i>	
Hydraulics	1.4	<i>Pressures</i>	
Servicing	1.4	<i>Noise levels</i>	
Decal identification	1.6	<i>Drawbar loads</i>	
		<i>Load capacities</i>	
		<i>Vibration declaration</i>	
		Main electrical circuit	4.4
		Road lights electrical circuit	4.5
<b>OPERATION</b>		<b>PARTS</b>	
Dumper controls	2.1	This section, at the rear of the book, is a pictorial parts catalogue.	
Running-in a new engine	2.3		
Pre-start checks	2.3		
Lister-Petter TR 1 engine	2.4		
Engaging the gear lever	2.7		
Gradients	2.7		
Braking	2.7		
Stopping the Dumper	2.7		
Leaving the Dumper	2.7		
Skip operation	2.8		
Skip operation & Steering	2.8		
Towing with the Dumper	2.9		
Towing the Dumper	2.9		

## THE HANDBOOK

The contents of this Handbook, although correct at the time of publication may be subject to alteration by the Manufactures without notice. Winget Limited operate a policy of continuous product development. Therefore, some illustrations or text within this publication may differ from your machine.

**WARNING**



*The operator must read all the Handbook and fully understand its contents before attempting to operate the machine.*

### THE HANDBOOK MUST NOT BE REMOVED FROM THE MACHINE.

The Handbook must be kept clean and in good condition. Additional copies of the Handbook can be obtained from your Distributor.

The contents of this Operator's Handbook are designed as a guide to the machine's controls, operation, working capacities and maintenance. It is **not** a training manual.

Only trained operators should use this machine. Consult your Distributor for details of authorised training courses..

**WARNING**



In this Handbook are **WARNING** notes. They are preceded by this symbol:

**WARNING**



*These notes are used to indicate the procedure being described in the Handbook must be followed to avoid serious injury or death to yourself or to others; or damage to the machine.  
The warnings are also used to protect the machine from unsafe servicing practices.*

Pay particular attention to the warnings given in the Handbook.

If you have any doubts about any aspect of the machine's capability or servicing procedures, you must consult the manufacturer.

## MACHINE IDENTIFICATION

Please record the model and serial numbers of your dumper in the spaces provided and quote them when ordering parts.

Model – Year .....	Front axle serial no. ....
Dumper serial no. ....	Front tyre size .....
Key, start .....	Rear tyre size .....
Engine serial no. ....	
Gearbox serial no. ....	

## WARRANTY TERMS & CONDITIONS

The Manufacturer assures you that if any part of the machine becomes defective due to faulty manufacture or materials within 12 months from the date of purchase, the part will be repaired or replaced under warranty free of charge by any authorised Winget Distributor. Warranty repairs **must** be carried out by Winget Distributors.

This Warranty is given to the first owner and may be transferred to subsequent owners for the balance of the Warranty period.

The Manufacturer's liability only extends to the costs of repair or replacement of the faulty parts and necessary labour charges involved in the repairs. The Company accepts no liability for any consequential loss, damage or injury, resulting directly or indirectly from any defect in the goods.

Items not covered by Warranty and considered to be the customer's responsibility include normal maintenance services; replacement of service items and consumables; replacement required due to abuse, accident, misuse or improper operation; replacement of wearable items e.g. pins, bushes, brake linings, clutch linings etc.

The Warranty will not apply where the equipment is modified, converted, or used for purposes other than those for which it was designed, unless clearance for the modifications etc. have been granted by the Manufacturer, in writing.

The Pre-Delivery Inspection and Warranty Registration Document must be completed correctly and returned to the Manufacturer within 7 days of sale date. Failure to do so may result in the claim being subsequently rejected.

Tyres and tubes are not covered by Warranty, but are covered by the tyre manufacturer's own warranty system which provides against defects in material or workmanship. Engines are covered separately by the engine manufacturers, and engine warranty repairs must be handled by the relevant engine manufacturers' distributors.

No claim will be considered if other than genuine Winget Limited parts, which must be obtained from Winget Limited via an authorised Distributor, are used to effect a repair, or if lubricants other than those recommended by Winget Limited are used.

The equipment must be serviced in accordance with the service schedules laid down by Winget Limited. Evidence that these have been complied with may be required before Warranty Claims are reimbursed.

The Manufacturer's policy is one of continuous improvement. Winget Limited reserve the right to change specifications without notice. No responsibility will be accepted for discrepancies which may occur between specification of machines and the descriptions contained in publications.

Safety is the responsibility of the persons working with this machine. Think “safety” at all times. ***Read and remember the contents of this Handbook.***

**The safe working recommendations for specific tasks are found with the instructions for the relevant operation in this Handbook.**

## **MACHINE MODIFICATION**

**WARNING** Any modifications to the machine will affect its working parameters and safety factors. Refer to the Manufacturers before fitting any non-standard equipment or parts.



The manufacturers accept no responsibility for any modifications made after the machine has left the factory, unless previously agreed by the Manufacturers in writing. The Manufacturers will accept no liability for damage to property, personnel or the machine if failure is brought about due to such modifications, or fitment of spurious parts.

## **TRAINING**

**WARNING** Only trained operators should use this machine.



Operators should hold an appropriate full motor vehicle driving licence and undergo both a safety awareness course and a operator training course for Site Dumpers run by a relevant training organisation.

It is strongly recommended that operators read the publication "Safe Working with Small Dumpers" which is available from bookshops to order quoting the following number ISBN 011 8836935. Another useful publication is British Standard number BS 6264, "Procedure for Operator Training For Earth Moving Machinery" available from the British Standard Institution.

## **RUNNING-IN**

**WARNING** While a gradual 'running-in' of a new engine is not necessary, it is extremely important that the instructions given in *Section 2 "Operation"* on "Running-in a new engine" should be followed very closely during the first fifty hours of operation



## **DRIVING**

**WARNING** *NEVER* use the machine for purposes other than those for which it was designed. This machine was designed to carry loads such as soil, clay, sand, wet concrete, stone or other similar materials. It was not designed to carry loads which may move around in the skip uncontrollably, nor to carry any loads or materials which overhang the skip in any way. If in any doubt as to the suitability of this machine for a particular task, contact your nearest Distributor or the Manufacturer for advice.



*ALWAYS* be aware of local and national regulations governing the use of the machine.

*NEVER* commence work with the machine until the “Daily (or every ten hours)” service checks have been made. (See Service Section for details)

*ALWAYS* check wheel nut tightness daily

*NEVER* carry passengers

Ensure that the seat is securely fixed to the machine. Where seat belt restraints are fitted as part of Rops/Fops protection they must be worn. Check that the seat belt is in good condition, free from cuts and frayed edges.

*ALWAYS* remain in the driving seat whenever the engine is running. Never attempt to operate any controls unless seated.

*ALWAYS* apply the parking brake before leaving the driver’s seat.

*NEVER* dismount with the engine running, and never leave the machine unattended with the key in the start switch.

Where Battery Isolators are fitted they must be activated only when the engine is turned off except in cases of emergency

Activating a Battery Isolator when the engine is running can result in damage to the electrical components and circuits.

*NEVER* fill the fuel or hydraulic tanks with the engine running.

*ALWAYS* drive only on surfaces that are known to be stable.

*ALWAYS* keep the floor plates and walkways clean.

*NEVER* drive the machine close to the edge of any excavation. Always use effective wheel stops to prevent the machine running close to the edge. Make sure that the stops are in proportion to the size of the wheels and are set sufficiently far enough back from the edge of the excavation to prevent the weight of the load causing a collapse.

*NEVER* adjust the tyre pressure in an attempt to improve traction on soft ground or obtain a softer ride on hard ground. Incorrectly adjusted tyres can affect the steering and handling characteristics

*NEVER* attempt to free a machine which is “bogged down” by pushing with the bucket of a backhoe loader, tracked excavator or other similar machine.

*NEVER* make unnecessary “crash stops” when travelling at speed, especially in forward direction.

*NEVER* work under an unpropped skip, If the dumper was supplied with a special skip support always ensure that it is used.



**SKIPS AND LOADING****WARNING**

*NEVER* exceed the rated payload. The weights of all loads above skip water level must be checked.

*NEVER* remain on the machine when loading the skip with excavators or loaders. Stop the engine, apply the parking brake, dismount, and stand well clear.

*ALWAYS* ensure that the load is evenly distributed in the skip.

*NEVER* carry loads or heap materials in such a manner as to affect the forward vision.

*ALWAYS* take extra care when tipping non free running loads.

*NEVER* use the skip in a tipped position to bulldoze *heaped materials level* or to backfill material into excavations.

*NEVER* try to operate the hydraulic tipping skip whilst steering on hydraulic power steering models, there is no priority flow to the steering

**TOWING****WARNING**

*NEVER* attempt to start the engine of a dumper by towing or pushing.

*Dumpers are not designed as towing vehicles. However, trailers may be towed provided that:*

- 1 The combined weight of the trailer and its load does not exceed the dumper "drawbar pull of 250kg (2500N)" and dumper "drawbar load of 50kg (500N)".
- 2 Trailers may be towed in first gear on level dry ground, provided a purpose made towing pin is used.
- 3 The dumper skip must be loaded with half the rated payload to ensure tyre adhesion when braking.

*NEVER* tow loads up, down or across gradients.

**GRADIENTS****WARNING**

*NEVER* operate **Two Wheel Drive rigid chassis Dumpers** on any gradients which exceed 10% (1 in 10), or across gradients which exceed 10% (1 in 10).

*ALWAYS* remember that slippery or loose surface conditions can adversely affect safe machine operation, including braking, particularly on gradients.

*ALWAYS* choose routes that avoid steep, slippery or loose gradients.

*NEVER* coast down gradients. Always negotiate gradients in first gear.

*ALWAYS* drive forwards up gradients when loaded.

*ALWAYS* reverse down gradients when loaded.

*ALWAYS* keep the load facing uphill.

*NEVER* park on a gradient. If this is unavoidable, *ALWAYS* chock the wheels.

*NEVER* attempt to turn on a gradient.

*NEVER* tow up, down or across a gradient.

## HYDRAULICS

### WARNING



*ALWAYS* "Dump" residual pressure from the system before leaving the machine or before carrying out any maintenance or adjustments.

If maintenance work requires the skip to be in the raised position, then it must be raised and supported before dumping the pressure.

Dump pressure by switching off the engine, then moving the hydraulic control lever several times in each direction.

*NEVER* leave the machine unattended with pressure in the system.

*ALWAYS* purge hydraulic rams before commencing work. With the engine running operate the hydraulic control to fully extend and retract the rams. Then operate the steering lock to lock.

*ALWAYS* practise the greatest cleanliness when maintaining hydraulic components.

## SERVICING

### WARNING



*ALWAYS* report any defect at once, before an accident or consequential damage can occur.

*ALWAYS* conform to service schedules except where:

- 1 Warning lights or warning indicators, if fitted, call for immediate attention.
- 2 Adverse conditions necessitate more frequent servicing.

*ALWAYS* wear correctly fitting protective clothing. Loose or baggy clothing can be extremely dangerous when working on running engines or machinery.

*ALWAYS*, where possible, work on or close to engines or machinery only when they are stopped. If this is not practical, remember to keep tools, test equipment and all parts of your body well away from the moving parts.

*ALWAYS* "Dump" pressure from the hydraulic system before carrying out any kind of maintenance or adjustment. (**see Service - Hydraulic system**).

*ALWAYS* avoid contact with exhaust pipes, exhaust manifolds and silencers when the engine is running; these can be very hot.

*ALWAYS* work out of doors, or in a well-ventilated area.

*NEVER* run an engine in an enclosed space. Exhaust fumes in enclosed areas can kill.

*ALWAYS* disconnect battery cables and remove battery before using an external charger, carrying out welding repairs or to prevent unauthorised usage when unattended or during a repair.

*NEVER* allow unqualified personnel to attempt to repair, remove or replace any part of the machine, or anyone to remove large or heavy components without adequate lifting tackle.

*NEVER* attempt to modify or repair Rops Frames or Fops Canopies by welding, drilling or any other means. Attempts to do so will invalidate Rops/Fops Certification.

*ALWAYS* obtain advice before mixing oils; some are incompatible. If in doubt drain and refill.

*NEVER* allow oils and fuels to come into regular contact with skin. This can lead to serious skin diseases including, medical evidence suggests, skin cancer. *ALWAYS* wear protective gloves when handling oils and fuels whether topping up, draining or refilling. *ALWAYS* wash hands if oils or fuels come into contact with the skin.

Many liquids used in this machine are harmful if taken internally or splashed into the eyes. In the event of accidentally swallowing oils, fuels, anti-freeze, battery acid etc, *DO NOT* encourage vomiting, seek qualified medical assistance immediately.

*ALWAYS* dispose of waste oils and fuels into waste oil storage tanks. If storage tanks are not available consult your distributor or local authority for addresses of local designated disposal points. It is illegal to dispose of waste oil into drains or water courses or to bury it.

*ALWAYS* dispose of unserviceable batteries safely. Comply with local byelaws and national regulations on the disposal of hazardous waste. Consult your local authority for addresses of local designated disposal points.

Equipment that includes friction materials will sometimes contain asbestos. When removing friction material dust from components, such as when servicing brakes or clutches, do not blow out with an airline; it could be harmful to inhale the dust. Remove the dust with a vacuum cleaner or wipe clean with a damp rag. Waste should be placed in a sealed container, marked, and disposed of in accordance with local or national regulations.

The accumulated dust found in clutch housings may contain lead/antimony. No food should be eaten at a work place contaminated by this dust. Hands must be washed before eating. Do not blow out dust with an airline.

*NEVER* work under an unpropped skip. ***If the dumper was supplied with a special Skip Support always ensure that it is used.***

*ALWAYS* ensure that when using a starting handle that it is clean and in good condition. Keep the engine starting dog and the part of the starting handle that mates with it lightly lubricated (*Refer to the Engine Handbook*).

## DECALS

**Attached to the dumper are several pictorial warning decals**

Ensure that all warning decals fitted to the mixer are legible. If any should become detached, they must be replaced immediately.

For detailed information on how to safely use the items described by the decals, see the "Safe working, Operation and Servicing" sections of this Handbook.

**Brief descriptions of the pictorial decals are as follows:**

Fuel tank filling point

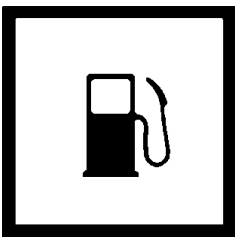

Wear ear protection



Hydraulic oil filling point

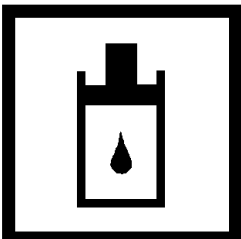

The battery isolator is situated close to this decal

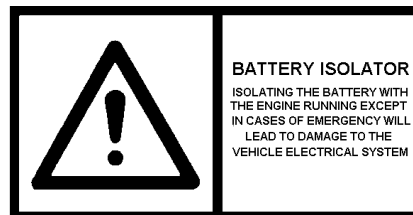

Remove starting handle

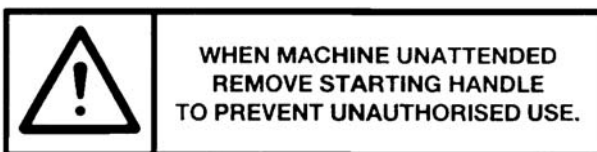

Read Operators Handbook, or Operators Handbook storage place.

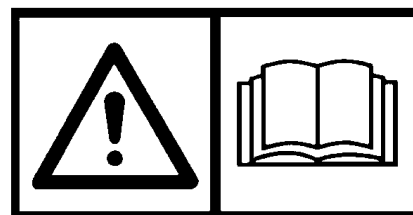

Attach lifting hooks to this eye.



The battery negative terminal is connected to earth.

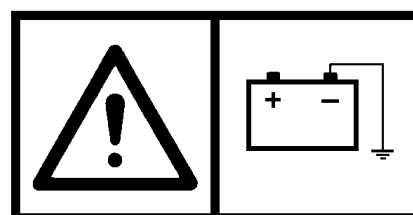

This decal indicates the maximum loads that the dumper towbar can carry and pull.

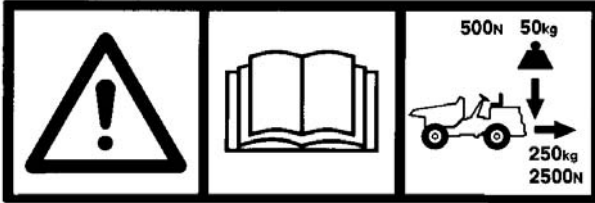

Forks and buckets are not to be used to push or lift the dumper.

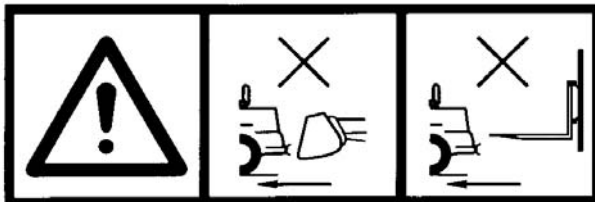

The figure shown is the maximum load for the skip onto which this decal is fastened

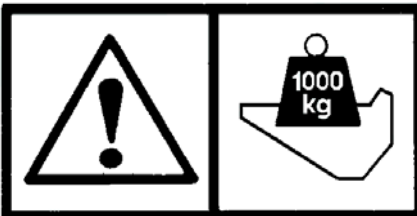

The figure shown is the maximum load for the skip onto which this decal is fastened

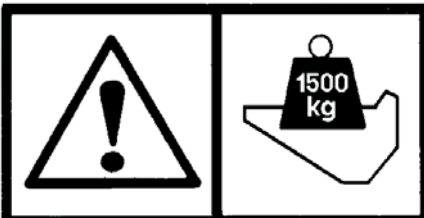

Beware of electrical hazards.

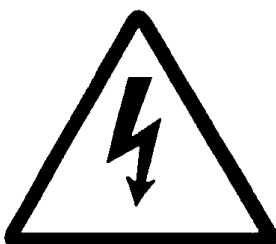

These surfaces may be hot.



When loaded, always REVERSE down gradients.

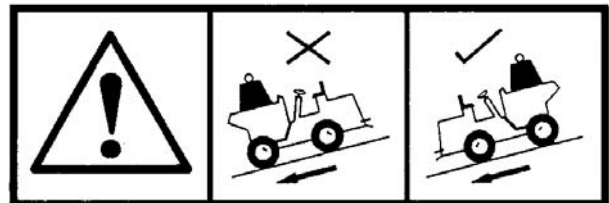

ISO Skip Support, when used, is pinned around the tipping ram rod to prevent the ram from closing.

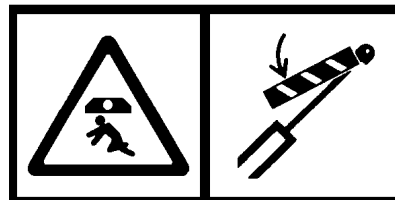

Wear eye protection



ISO 8999 safety symbols used with Lister/Petter engines



Read the handbook

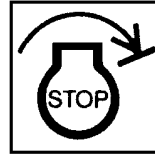
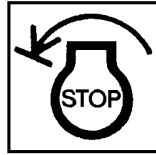

Stop control (on engine)

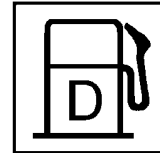

Diesel fuel fill



Engine oil fill



Engine oil level

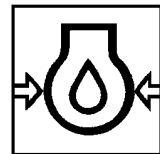

Engine oil pressure

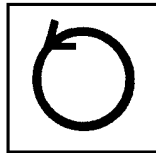

Anti-clockwise rotation

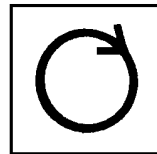

Clockwise rotation



Lifting eye - engine only

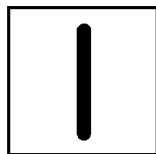

On

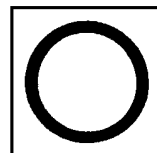

Off

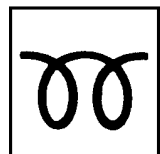

Pre-heat



Rotational speed control



Linear speed control



Tachometer



Elapsed hours



Battery charging

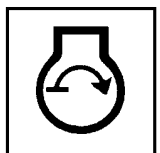

Engine cranking



Electrical hazards



General hot surface warning

**CONTROLS AND SERVICE POINTS**

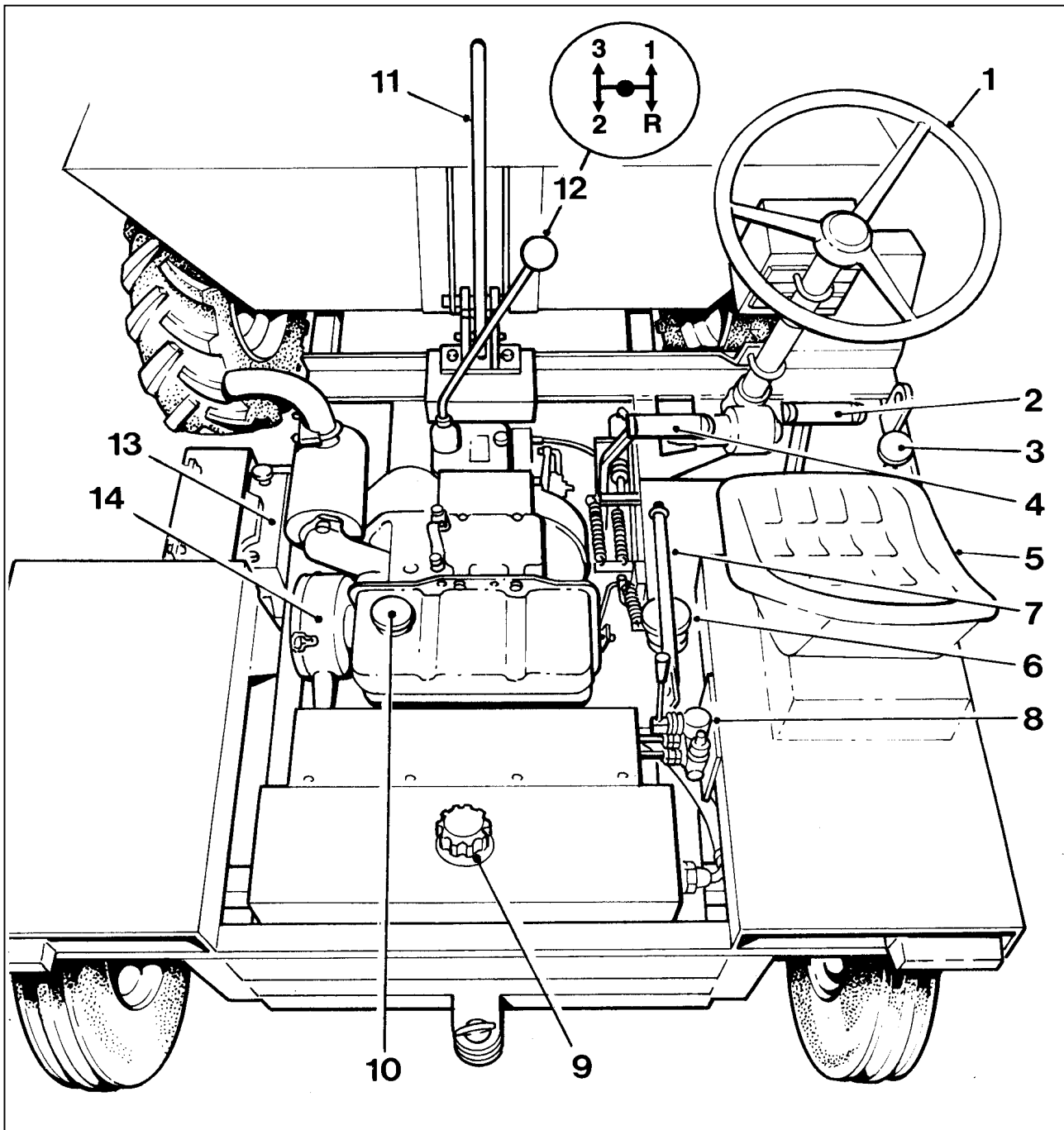

1 Steering wheel

2 Brake

3 Accelerator

4 Clutch

5 Seat

6 Brake oil reservoir

7 Parking brake

8 Skip control, tip/return  
(Hydraulic tipping)

9 Hydraulic oil filler cap

10 Fuel filler cap

11 Skip release lever (Manual tipping)

12 Gear lever

13 Battery

14 Engine air cleaner

## ELECTRICAL CONTROLS

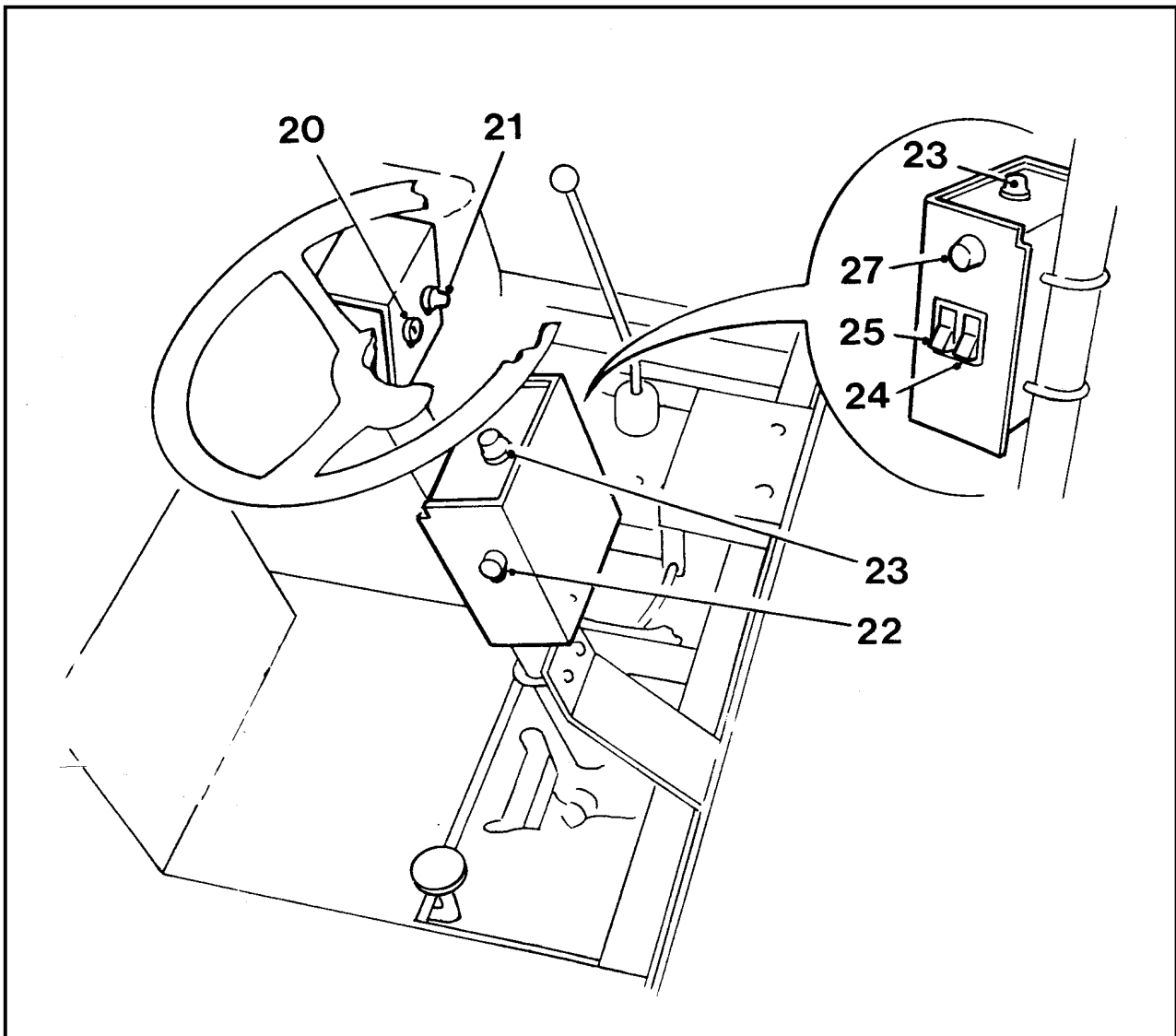

- 20 Key start switch, (electric starting only)
- 21 Warning light: battery charging (electric starting only)
- 22 Switch: direction indicators
- 23 Warning light: direction indicators
- 24 Switch: hazard warning lights
- 25 Switch: side and head lights
- 27 Horn



## DRIVING THE DUMPER

### Safety warnings

Read also the "**Safe Working**" Section before operating the dumper.

**WARNING**  ALWAYS wear correctly fitting protective clothing. Loose or baggy clothing can be extremely dangerous when operating or servicing machinery.

*Only skilled personnel are permitted to work with this machine.*

*ALWAYS be aware of local and national regulations governing the use of this machine.*

### Starting the engine

**WARNING**  NEVER use ether type starting aids.

*ALWAYS stop the engine if the battery charge warning light (where fitted) fails to cancel.*

*ALWAYS stop the engine if warning lights illuminate. Detect the fault before continuing.*

**DO NOT PROCEED IF A FAULT IS EVIDENT**

*NEVER attempt to start the dumper by pushing or towing.*

*NEVER operate controls unless you are seated on the machine, and ALWAYS remain in the driving seat whenever the engine is running.*

### Running-in a new engine

While a gradual 'running-in' of a new engine is not necessary, it is **EXTREMELY IMPORTANT** that the following instructions should be followed very closely during the first fifty hours of operation.

- 1 Avoid overloading the engine.
- 2 Use the lower gears when operating with heavy loads, and avoid continuous operation at constant engine speeds.
- 3 Check the instruments frequently, and keep the oil compartments and the hydraulic reservoirs filled to their recommended levels.
- 4 Do not operate the engine at high speeds without a load.
- 5 Do not allow the engine to run at idle speeds for long periods; this may cause bore glazing and an increase in oil consumption.

Operating in this way throughout the machine's life will prove beneficial to its overall performance and efficiency.

### Pre-start Checks

*NEVER commence work with the machine until the checks detailed in "Every 10 operating hours, or daily" have been carried out. (See Service Schedule).*

**WARNING**



Check that all controls are clean and not slippery, and that they all function correctly.

Check that the areas around pivot points, rams and linkages are all free from mud, ice and debris.

Check that all grab handles, steps and platforms are clean and dry.

Check the machine for any obvious damage or faults.

Check that all decals can be clearly read.

## DRIVING THE DUMPER

### Lister Petter TR1 engines

#### Description

- A Dipstick
- B Lubricating oil filler
- C Engine control
- D Decompressor levers
- E Fuel tank
- F Cold start oil cups

#### Automatic Excess Fuel Device

The engine is fitted with an automatic excess fuel device which becomes operative, ready for the next start, when the engine is stopped.

If the engine stops other than by the operation of the engine control, the control (G) must be turned anti-clockwise to the 'STOP' position and released before the device can operate.

As the engine runs up to speed the excess fuel device will automatically reset to the normal running position.

#### Cold Start Below -10 deg.C (14 degF)

A cup and plunger is normally fitted to the combustion air intake port on TR engines.

With the fuel turned on, turn the engine for up to 20 revolutions to prime the fuel and lubrication systems.

Withdraw the plunger (H) and fill one third of the cup (J) with the same type of lubricating oil as used in the engine.

Replace the plunger and inject the oil just before starting the engine.

#### WARNING



*The device must not be used more than three times in succession during the same attempt to start the engine.*

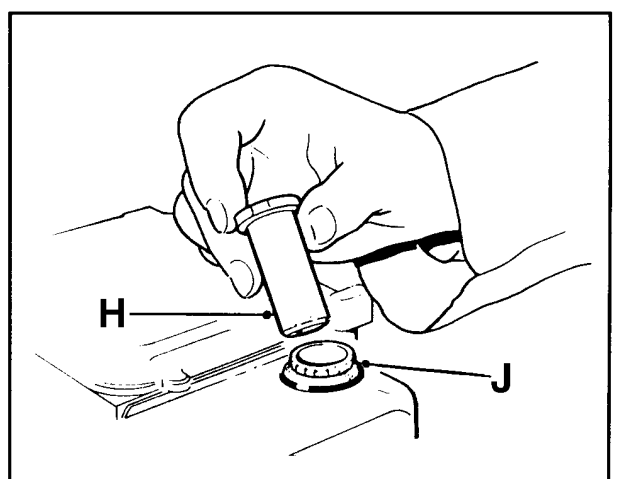
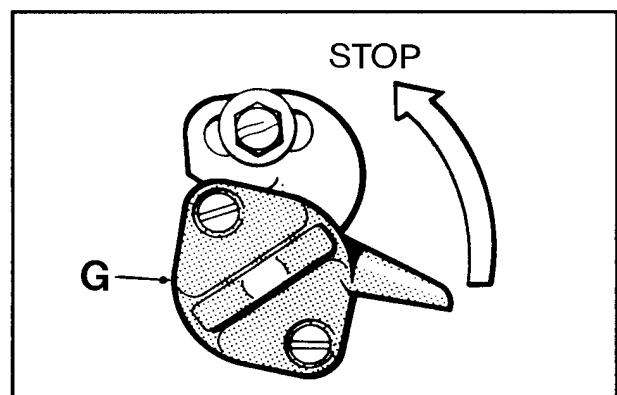
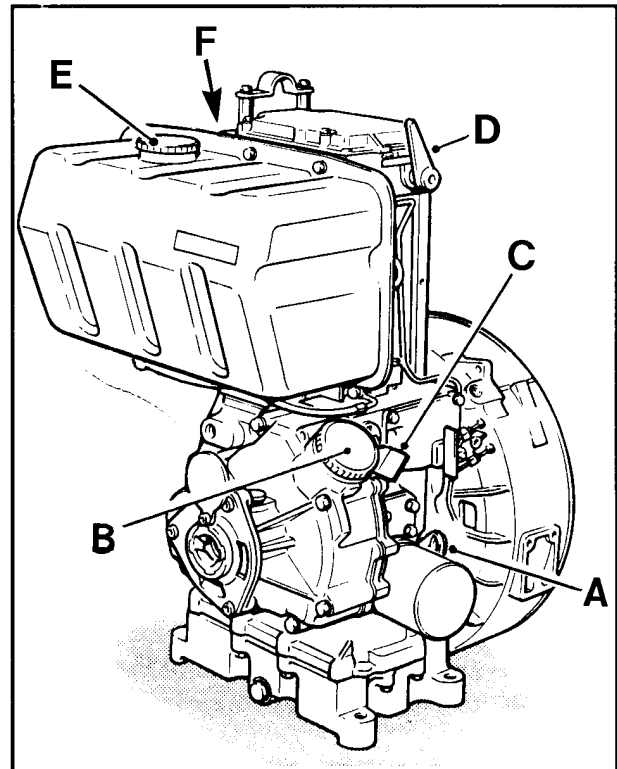

## DRIVING THE DUMPER

### *Hand starting TR1 engines*

Ensure the parking brake is in the raised "ON" position.

Ensure gear lever is in the neutral position.

**Always use the correct starting handle which has been designed for the engine.**

Ensure there are no burrs on the handle.

Before attempting to use the handle, clean and lightly oil that part of it which fits onto the engine.

**WARNING** *Do not attempt to use a handle if it is damaged in any way.*



Turn the engine control lever anti-clockwise to the "STOP" position (**L**) and release it.

Move the decompressor lever towards the flywheel (**M**).

Insert the correct handle into the starting housing.

Turn the engine slowly for up to 20 turns to prime the combustion chamber and lubricating oil system.

Maintaining a firm grip on the starting handle, crank the engine really fast and when sufficient speed is obtained move the decompressor lever away from the fly wheel (**N**) and continue to crank until the engine fires.

Retain a firm grip on the handle and remove it from the engine.

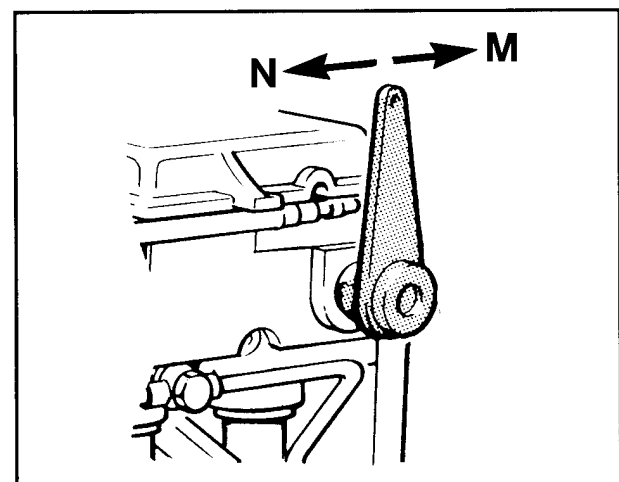
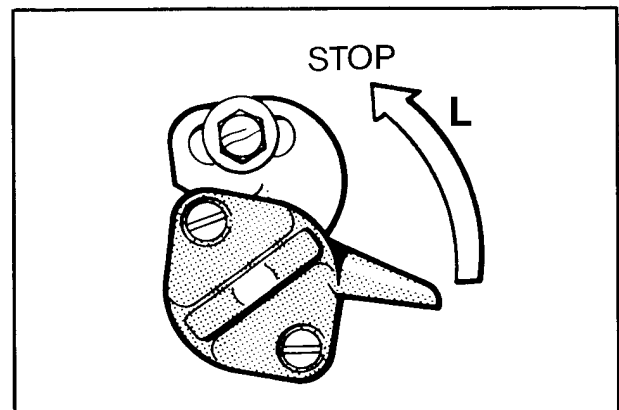

## DRIVING THE DUMPER

### *Key Starting TR1 engines*

Ensure the parking brake is in the raised "ON" position.

Ensure the gear lever is in the neutral position.

Fully depress and hold down both clutch and accelerator pedals.

Check that the decompressor lever, (if fitted) is away (**N**) from the flywheel.

Turn the engine control lever anti-clockwise to the "STOP" position (**L**) and release it.

Turn the start key clockwise to position (**1**), the battery charging light (**P**) will illuminate.

Turn the key and hold at the "START" position (**2**) until the engine fires and then release it immediately.

If the engine fails to start within 20 seconds, release the key and attempt to restart after allowing sufficient time for all moving parts to stop.

### *Stopping the engine*

**WARNING** *Never stop the engine by operating the decompressor lever or valve damage may occur*



**Key start engines:** *Turning the starter key to the "OFF" (0) position will not stop the engine unless an optional fuel control solenoid is fitted.*

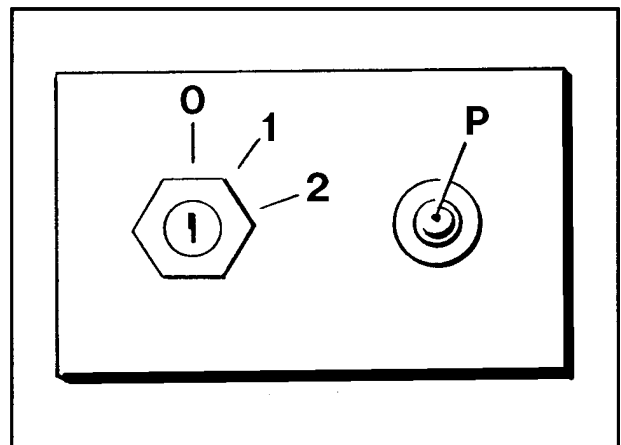

It is advisable to run on light load for a few minutes before stopping

Turn the engine control anti-clockwise to the "STOP" position (**L**) and hold it there until the engine comes to rest.

Key start engines: After the engine has stopped, turn the starter key to the "OFF" (**0**) position.

## **DRIVING THE DUMPER**

### **Gradients**

**IMPORTANT:** Read the notes in "Safe Working" and also remember the following:

Slippery or loose surface conditions can adversely affect safe machine operation, particularly on gradients.

**ALWAYS** choose routes that avoid steep, slippery or loose gradients.

**NEVER** park the machine on a gradient.

**NEVER** attempt to turn on, or drive across, a gradient.

**ALWAYS** drive forwards up gradients when loaded.

**ALWAYS** reverse down gradients when loaded.

**NEVER** tow up or down gradients.

**NEVER** operate on a gradient which exceeds 10% (1 in 10), or across gradients which exceed 10% (1 in 10). This should be reduced where surfaces are wet or unstable.

### **Braking**

The brake pedal operates a hydraulic master cylinder that supplies oil to brakes within the front axle. There are no brakes on the rear axle.

The handbrake operates a caliper that acts upon a disc mounted on the transmission.

### **Engaging gear lever**

The gearbox incorporates a self centering safety device on the gear lever which may make the gear lever stiff to operate. When changing gear, always depress the clutch pedal before moving the gear lever from one gear to another. The gearbox is not a synchromesh type gearbox.

### **Stopping the dumper**

**IMPORTANT:** Never make unnecessary 'crash' stops when travelling at speed, especially in forward direction.

Release accelerator and brake to a halt progressively.

Select neutral gear.

Apply parking brake when stationary.

Stop the engine. Turn the starter key to the 'OFF' position, and remove the key.

### **Leaving the dumper**

Ensure the machine is parked on firm, level ground. Do not park on a gradient.

Check that the parking brake is applied. Ensure that the skip is fully lowered.

With the engine stopped, operate the hydraulic lever (where fitted) fully in each direction several times to 'dump' hydraulic pressure from the system.

Remove starter key (where fitted) from switch.

*Electric start dumpers:* If unattended for some time, remove earth cable from battery, or activate the Battery Isolator, (where fitted).

## DRIVING THE DUMPER

### Skip operation

#### Loading

Never remain on the dumper when using excavators or loaders to load the skip. Stop the engine, apply the parking brake, dismount, and stand well clear.

Ensure that the load is evenly distributed in the skip. Never carry loads in such a manner as to affect the forward vision.

Never exceed the rated payload. The weights of all loads above skip water level must be checked.

#### Tipping

Only discharge on level ground.

It is recommended that only free flowing materials be tipped. *Take extra care when tipping non free running loads.*

#### Release lever (Gravity tipping)

*To tip the skip:*

Pull back the Release Lever. The skip will tilt forwards under its own weight.

*To return the skip:*

Pull the skip back manually into the carrying position. Ensure that it is locked into the skip catch.

#### Skip control lever (Hydraulic tipping)

The control lever has three positions; they are, Tip(or Dump), Hold and Return

*To tip the skip:*

Move the lever to DUMP.

*To return the skip:*

Move the lever to RETURN.

If the tipping lever is released when in the DUMP or RETURN position, it will automatically return to the central HOLD position and movement of the skip will stop. In this way, the speed at which the skip is tipped can be finely controlled.

#### Skip Operation & Steering

Do not attempt to steer the dumper at the same time as operating the skip.

The hydraulic system does not provide priority flow to the steering system, therefore the steering will fail to work whilst the skip is being operated.

## DRIVING THE DUMPER

### Towing with the dumper

Dumpers are not designed as towing vehicles, however, trailers may be towed providing that:

- 1 The combined weight of the trailer and its load does not exceed the specified maximum dumper drawbar pull and dumper drawbar load (*see specifications*).
- 2 Trailers may be towed in first gear on level dry ground, provided a purpose made towing pin is used.
- 3 The dumper skip must be loaded with half the rated payload to ensure tyre adhesion when braking.

Never tow loads up, down or across gradients.

### Towing the Dumper

The dumper should only be towed if recovery is needed of a broken-down unit, or to free a "bogged down" machine.

Always ensure that ropes, chains, etc.. used to tow the dumper have sufficient safe working load capability.

When towing the dumper, always ensure that the speed is kept to an absolute minimum.

Always tow the dumper with the gear lever in neutral.

Never attempt to start the dumper by pushing or towing.

**WARNING** *Read the safety notes in "Safe Working", Section 1 of this book.*



*Also note the following:*

### **Safe handling of oils, filters and filter elements**

**WARNING** *Do not allow oils to come into regular contact with skin. This can lead to serious skin diseases. Medical evidence suggests they may include skin cancer.*



*Always wear protective gloves when handling oils for topping up, draining, or refilling.*

*Dispose of waste oil into waste oil storage tanks. If storage tanks are not available, consult your Distributor or local authority for addresses of local designated disposal points.*

*It is illegal to dispose of waste oil into drains or water courses or to bury it.*

*The materials used in the manufacture and treatment of some filters and elements may cause irritation or discomfort if they come into contact with the eyes or mouth and they may give off toxic gases if they are burnt.*

*After handling any filters or oils the user's hands should be thoroughly washed, particularly before eating.*

*Used filter elements contain some of the filtered oil and should be handled and disposed of with care.*



**SERVICE SCHEDULE**

**IMPORTANT:** The engine will require additional services or adjustments in addition to those listed below (See the appropriate Engine Operator's handbook or Workshop Manual).

**WARNING** *Warning lights and indicators REQUIRE IMMEDIATE ACTION*



<b>SERVICE OPERATION</b>	<b>REFERENCE</b>	<b>PAGE</b>
--------------------------	------------------	-------------

***Every 10 operating hours, or daily, the above and the following***

Engine oil level	Engine	3.4
Fuel tank level	Engine	3.7
Air cleaner	Engine	3.7
Wheel nut tightness	Wheels & tyres	3.10
Axle oil seals	Front axle	3.19
Brake oil reservoir	Brake system	3.18
Hydraulic oil level & hose connection	Hydraulic system	3.14

***Every 50 operating hours, or weekly, the above and the following***

Axle nuts	Front axle	3.9
Front axle oil level	Front axle	3.9
Tyre pressure & condition	Wheels & tyres	3.10
Battery electrolyte level	Battery	3.11
Grease nipples	Greasing	3.13
Gearbox oil levels	Gearbox	3.8
Steering Valve Retention	Steering Valve	3.12
Parking brake Check function of the parking brake and adjust if necessary		
Propeller shaft Tighten securing nuts		
Brake pedal travel Check the action of the brake pedal; it should have a short travel and firm action. If travel is excessive, or action spongy, have the brakes serviced by your distributor.		

***First 100 operating hours***

Hydraulic oil filter	Hydraulic system	3.17
----------------------	------------------	------

**SERVICE SCHEDULE**

<b>SERVICE OPERATION</b>	<b>REFERENCE</b>	<b>PAGE</b>
--------------------------	------------------	-------------

**Every 125 operating hours, the above and the following**

Air cleaner element	Engine	3.7
---------------------	--------	-----

**Every 250 operating hours, the above and the following**

Engine oil & filter	Engine	3.5
Fuel filter	Engine	3.6

**Every 500 operating hours, the above and the following**

Air cleaner element	Engine	3.7
Fuel filter	Engine	3.6
Frame assembly bolts	Check all structural nuts & bolts for tightness	

**Every 1000 operating hours, the above and the following**

Hydraulic oil & filter	Hydraulic system	3.17
Gearbox oil change	Gearbox	3.8
Front axle oil change	Front axle	3.9

**Every 2000 operating hours, or 2 years, the above and the following**

Brake system overhaul	Braking system	3.18
-----------------------	----------------	------

**Extra services****Dirty working conditions**

Increase the frequency of all services during extremes of dirt, heat and cold, especially those relating to clean air, cooling efficiency, lubrication and machine cleanliness.

**Laying-up protection**

When a machine is to remain idle, remove the battery to the workshop. Seal all openings: air intake, exhaust breathers. Grease bright parts and protect rubber components from direct sunlight. Fill the fuel tank, check the tyre pressures and exhaust any pressure from the hydraulic system.

## ENGINE

## Lister-Petter TR1

The engine will require additional services and adjustments in addition to those quoted in this handbook. Please refer also to the relevant Engine Operator's Handbook or Workshop Manual.

## Engine lubrication oil

For engine oil grades and oil change periods when operating in temperatures above 30°C, see "Engine Handbook".

**WARNING**

*Lubrication oil cleanliness is vital for the successful operation of your engine. The oil should be stored under the cleanest possible conditions. When changing or topping-up oil, use only clean receptacles.*

*Always wear protective gloves when handling oils for topping up, draining, or refilling.*

*Oils and fuels can cause skin irritation. Wear suitable protective clothing to prevent skin contact.*

*After handling oils the users hands should be thoroughly washed, particularly before eating.*

## Every 10 operating hours, or daily

## Check lubrication oil level as follows:

Stop the engine and allow the oil to settle.

Remove and clean dipstick **(B)**, then check that the oil is at the full mark. If level is low, top up through the filler **(C)** to the full mark with clean oil of the correct grade. DO NOT OVERFILL.

*For correct grade of engine oil, see "Specifications"*

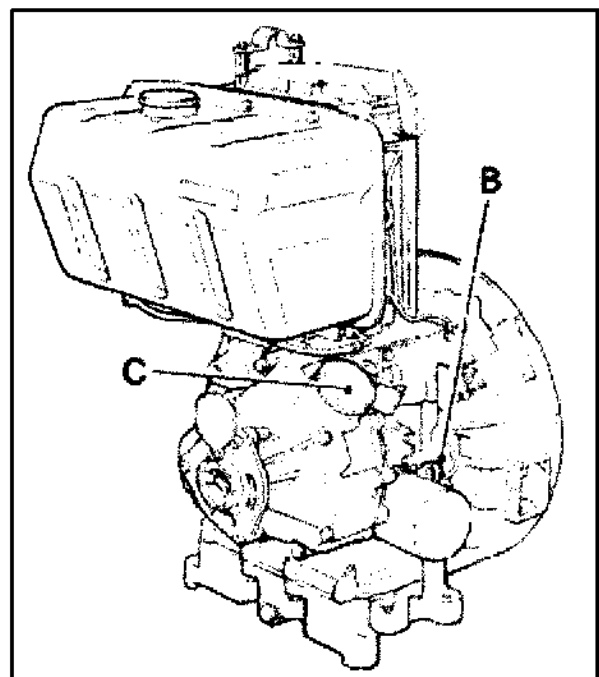

## ENGINE

## Every 250 hours

## Oil filter

Change oil filter element as follows:

Using a suitable strap wrench, unscrew and remove the old filter (A).

**Do not attempt to clean the old filter! Dispose of it safely.**

Thoroughly clean the crankcase filter housing face.

Apply a small amount of clean engine oil to the filter sealing joint.

**Do not use a strap wrench to fit the new element.**

Screw on the new filter by hand, until the sealing joint is just touching the crankcase and then tighten a further half turn.

## Drain and refill the oil sump

Change the sump oil as follows:

If possible run the engine immediately before draining the oil.

Place a suitable container under the drain plug. Remove the drain plug (D) and drain oil.

Clean and coat the threads of the drain plug with an appropriate sealant.

Replace the drain plug (D) taking care not to over tighten it.

Fill the sump through the oil filler (C) to the top mark on the dipstick (B).

Start the engine, run it for a few minutes and check the drain plug, and the oil filter do not leak.

Stop the engine, allow the oil to settle for 2 minutes. then check the level on the dipstick (B).

Add more oil if necessary.

*For correct grade of engine oil, see "Specifications".*

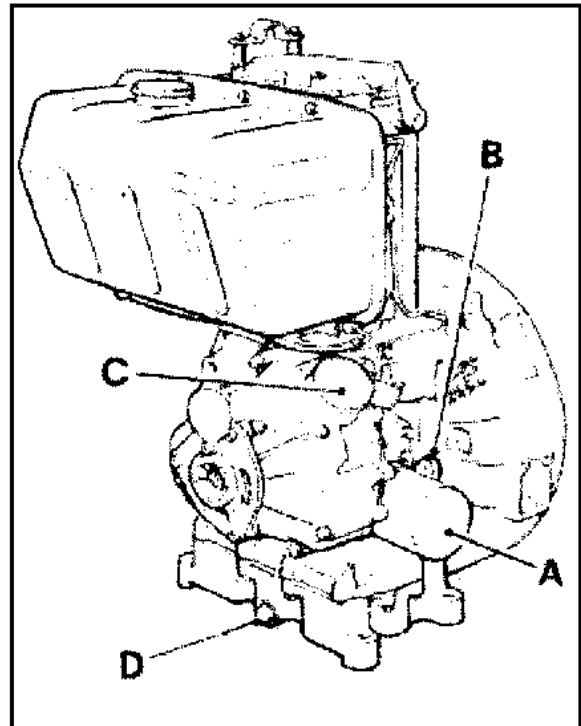

**ENGINE****Every 250 Hours****Fuel filter**

Change the fuel filter element if the fuel being used is not perfectly clean (see below)

**Every 500 Hours****Fuel filter**

Change fuel filter element as follows:-

Disconnect the fuel pipe from below the tank.

Remove retaining plug ( R ).

Remove the old element ( S ) and joint ( T ).

Replace and tighten the retaining plug ( R ).

Refit the fuel pipe.

Prime the system.

**Priming the fuel system**

Prime the system as follows:

Fill the fuel tank

Move the engine control lever to the RUN position.

Vent fuel at each pump in turn through the bleed screw ( U ) until a full air free flow of fuel is obtained. Tighten the bleed screw replacing the sealing washer if necessary.

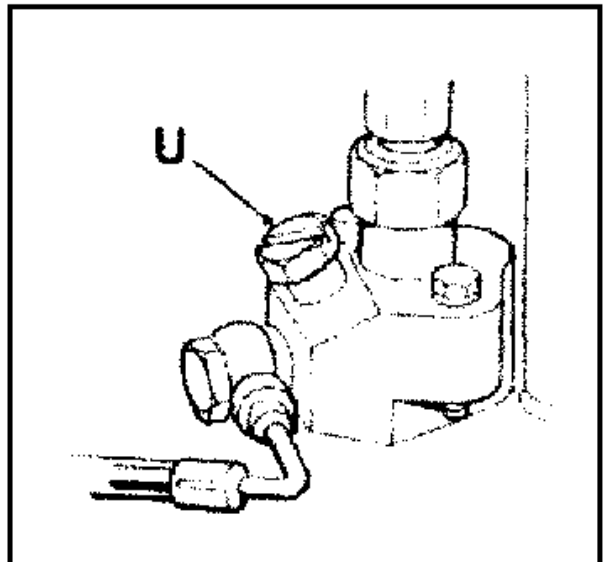
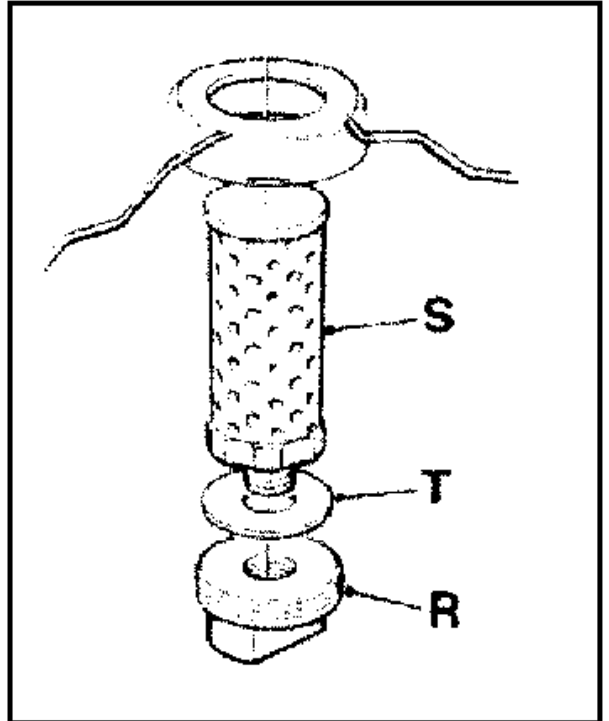

## ENGINE

**Every 10 operating hours, or daily****Fuel tank**

Fill the fuel tank at the end of each day to reduce overnight condensation within the tank.



**WARNING** Never mix gasoline or any other fuel mixes with diesel fuel because of increased fire or explosion risks.

Never remove the filler cap, or refuel, with the engine running.

Never smoke when refilling the tank.

**To fill the tank:**

Stop the engine.

Clean the area around the filler cap. Remove the cap.

Fill the tank. *Do not fill the tank to capacity. Allow room for expansion, and wipe up spilt fuel immediately, otherwise paintwork will be damaged.*

Replace cap.

**Every 10 operating hours, or daily****Air cleaner: check/clean/replace**

Check and clean or replace the element **(X)** under very dusty conditions.

Access the element by unclipping the metal cover.

**Every 125 operating hours****Air cleaner: check/clean/replace**

Check the air cleaner element, clean or replace if necessary

**Every 500 operating hours****Air Cleaner: replace**

Fit new air cleaner element

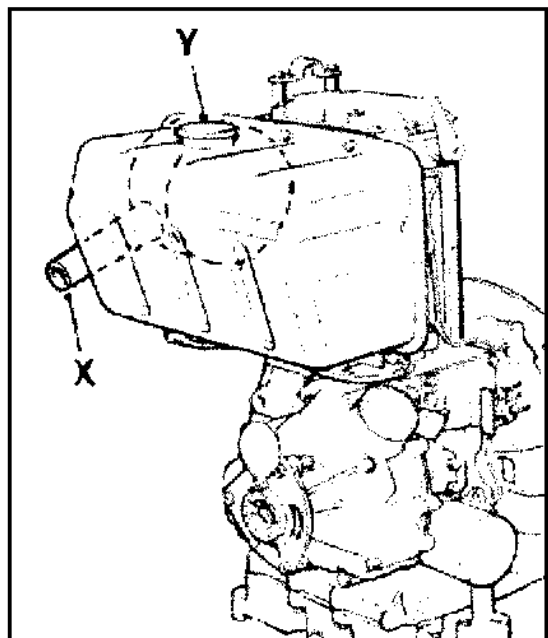

## ENGINE

## Safe handling of oils

## WARNING



*Do not allow oils to come into regular contact with skin. This can lead to serious skin diseases. Medical evidence suggests they may include skin cancer.*

*Always wear protective gloves when handling oils for topping up, draining, or refilling.*

*Dispose of waste oil into waste oil storage tanks. If storage tanks are not available, consult your Distributor or local authority for addresses of local designated disposal points.*

*It is illegal to dispose of waste oil into drains or water courses or to bury it.*

## Every 50 operating hours, or weekly

## Check gearbox oil level

Check the gearbox oil level when the machine has stood for 2 minutes.

Clean the area around the dipstick/filler (V) before removing.

Remove the dipstick and check the oil level. Top-up between the two marks (W). *It is most important not to overfill.*

For the correct type and grade of oil, see "Specifications".

## Every 1000 operating hours

## Change gearbox oil

Clean the areas surrounding the dipstick (V) and drain plugs (X).

Place a suitable container beneath the drain plug.

**CAUTION:** Before removing the drain plug be sure to stand to one side to avoid the oil that will spill from the hole.

Remove the drain plug (X) and drain the gearbox. *(Do not lose its sealing washer)*

Replace drain plug with its sealing washer. Remove the dipstick (V) from the filler hole.

Fill with oil. Check that the final level is between the two marks on the dipstick. *It is most important not to overfill.*

For the correct type and grade of oil, see "Specifications".

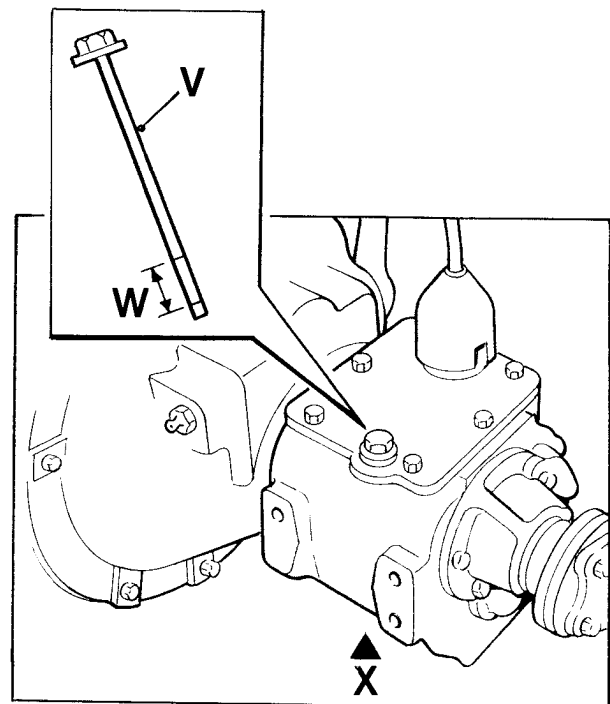

## FRONT AXLE

**Every 10 operating hours, or daily****Check for leaks**

Check for oil leaks around joints and seals.

**Every 50 operating hours, or weekly****Tighten securing nuts**

Tighten axle arm/main case joint securing nuts and half shaft nuts.

**Axle oil level**

Do not check the oil level until the machine has stood for 2 minutes.

Clean the area surrounding level/filler plug (D) before removing it.

The oil is correct when level with the bottom of the level/filler plug hole.

If the level is low, top-up with clean oil of the correct grade through the hole.

Replace plug (D).

*For the correct type and grade of oil, see "Specifications".*

**Every 1000 operating hours****Axle oil change**

Change the lubrication oil in the front axle as follows:

Clean the areas surrounding the level/filler plug (D), and drain plug (E).

Place a suitable container beneath the drain plug.

**CAUTION:** Before removing the plugs be sure to stand to one side to avoid the oil that will spill from the drain hole.

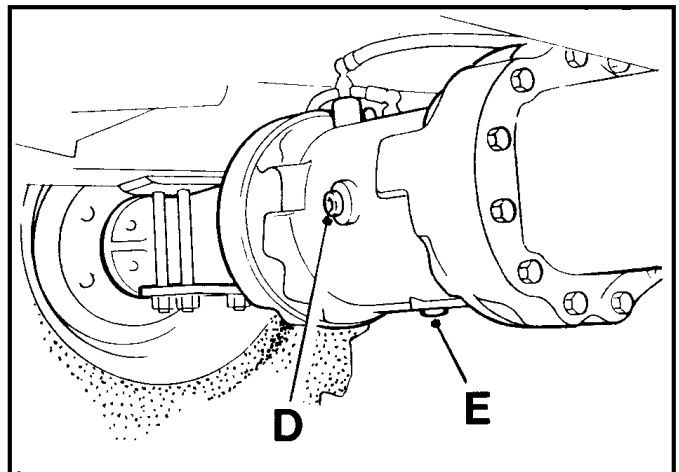

Remove drain plug (E) and drain oil from the casing. Replace drain plug.

Refill at the level/filler hole (D) with clean oil of the correct grade.

The level is correct when oil reaches the bottom of the hole.

Replace plug (D).

*For the correct type and grade of oil, see "Specifications".*



## WHEELS & TYRES

### Every 10 operating hours, or daily

#### Wheel nuts

Tighten wheel nuts whenever necessary, every ten hours or daily.

After a wheel change, the nuts should be checked several times a day until they maintain their correct setting.

*For wheel nut tightening torque, see "Specifications".*

### Every 50 operating hours, or weekly

#### Tyre pressures

**WARNING**

*ALWAYS ensure that when adding air to a tyre the area is clear of personnel.*

*NEVER over-inflate a tyre beyond its specified pressure.*

*NEVER adjust the tyre pressure in an attempt to improve traction on soft ground or obtain a softer ride on hard ground.*

*Incorrectly adjusted tyres can affect the steering and handling characteristics.*

Check the tyre pressures only when the tyres are cold.

*For correct pressures see "Specifications".*

#### Tyre condition

Check the tyres for damage and deterioration.

## BATTERY

## Safe handling of batteries

**WARNING**

*The battery contains a sulphuric acid electrolyte which can cause severe burns and produce explosive gases.*

*Wear protective clothing, gloves and goggles when servicing the battery.*

*Avoid contact with the skin, eyes or clothing. If spilled onto the skin, flush immediately with cold water. If splashed into the eyes, flush immediately with cold water for 15 minutes and get prompt medical attention.*

*Do not take internally. If accidentally swallowed, call a doctor immediately.*

*Do not use a naked flame or smoke near the battery. Do not produce sparks with cable clamps when charging the battery or starting the engine with a slave battery.*

*Always disconnect battery leads, or activate battery isolator where fitted, before carrying out any maintenance to the electrical system.*

*ALWAYS dispose of unserviceable batteries safely. Comply with local byelaws and national regulations on the disposal of hazardous waste. Consult your local authority for addresses of local designated disposal points.*

## Every 50 hours

**Check battery electrolyte level**

The battery is situated beneath a cover on the left-hand side of the dumper.

Ensure that the electrical connections are clean and tight, and coat the terminals with petroleum jelly to protect them from corrosion.

Remove battery filler plugs and check that the electrolyte level is between 6 - 9 mm (0.25 - 0.37 in) above the tops of the separators.

If necessary, top-up with distilled water. Replace battery filler plugs and tighten securely.

**Battery removal****WARNING**

*if the battery is to be removed from the machine, ensure the following procedure is used.*

Switch the engine off.

Remove the starter key from the machine.

Ensure all electrical circuits are switched off. Activate the battery isolator, where fitted.

Remove the battery cover and clamp.

Disconnect the earth (-) load from the battery before removing the positive(+) load.

Lift the battery from the machine.

**WARNING**

*When installing the battery, the positive (+) lead MUST be connected first.*

**STEERING VALVE**

**Every 50 operating hours, or weekly**

**Steering Valve Retention**

Check the screws retaining the steering valve and bracket, ensuring they are tight. Check the valve for signs of leaks or damaged hoses.

**Every 50 operating hours, or weekly**

**WARNING** *Always use lubricants of the grade specified.*  
 *Always lubricate and service BEFORE work commences, and WITHIN the periods specified.*

**Grease points**

Clean nipples BEFORE and AFTER greasing. Apply the grease gun until clean grease appears.

**Location of grease points**

- A Tipping rams (2 on each ram)
- B Skip pivots (2)
- C Propeller shaft (3)
- E Brake pedal pivot shaft (2)
- F Clutch pedal pivot shaft (2)
- G Accelerator pivot shaft (2)
- H King pins (2 on each pin)
- I Axle centre pin (1)
- K Gearbox lever pivot (1 each side of gearbox)
- # Clean and lubricate all linkages not fitted with a grease nipple.

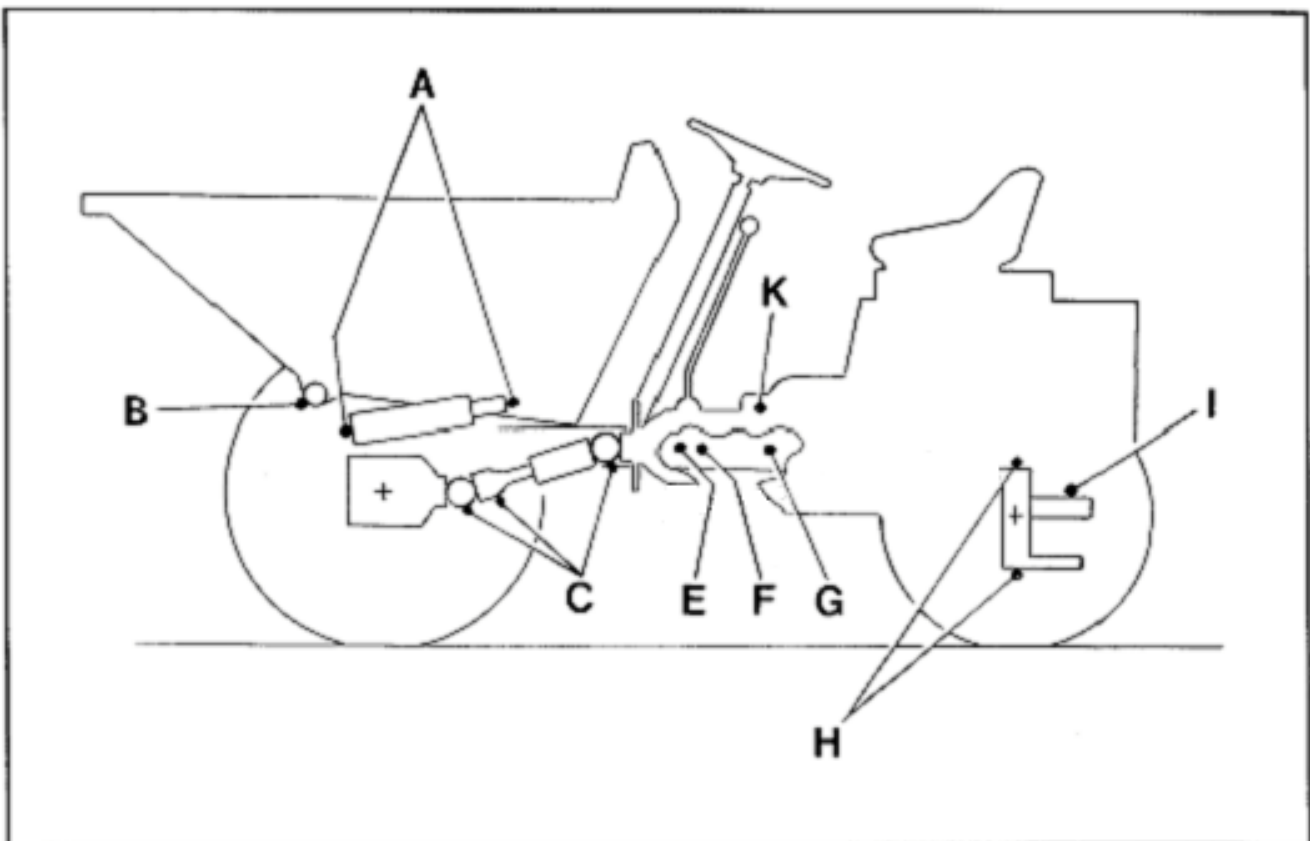

## HYDRAULIC SYSTEM

### Hydraulic System Safety

(see also "Safe Working" section)

**WARNING**



*Do not allow oils to come into regular contact with skin. This can lead to serious skin diseases. Medical evidence suggests they may include skin cancer.*

*Always wear protective gloves when handling oils for topping up, draining, or refilling.*

*Always practice the greatest cleanliness when servicing hydraulic components.*

*Always clean the areas surround filler points, filters etc., before and after servicing.*

*Dispose of waste oil into waste oil storage tanks. If storage tanks are not available, consult your Distributor or local authority for addresses of local designated disposal points.*

*It is illegal to dispose of waste oil into drains or water courses or to bury it.*

### Dumping hydraulic pressure

**WARNING**



*Always dump all hydraulic pressure from the system before servicing any hydraulic component.*

### To dump pressure:

**Stop the engine.**

**Move the skip control lever several times in each direction.**

### Description of hydraulic system

The hydraulic system provides power for skip tipping and the power steering.

#### The main components consist of:

**Tank:** The tank is filled through a filler/strainer which incorporates an oil level indicator. The filler cap is fitted with a breather. In the bottom of the tank is a suction filter.

**Pump:** The pump is driven directly from the engine

**Filter:** The filter is situated in the bottom of the tank. The oil is drawn from the tank, through the filter to the pump.

**Tipping control valve:** The control valve receives oil from the pump and delivers it to the skip tipping rams. The rate of oil flow to the rams is proportional to the distance that the control valve lever is moved.

If the control lever is held either fully to the left or right after the rams have reached their full stroke, a relief valve opens, allowing the oil to return to the tank. A high pressure carryover (H.P.C.O.) supplies oil under pressure to the steering valve.

**In Line Relief Valve:** The inline relief Valve, mounted on the hydraulic tank, is fitted to gravity tipping machines which do not have a Tipping Control Valve. The relief valve protects the hydraulic system in the event of an over pressure event.

The hydraulic system does not provide priority flow to the steering, therefore the steering should not be operated when the skip is being tipped or lowered.

Hydraulic system

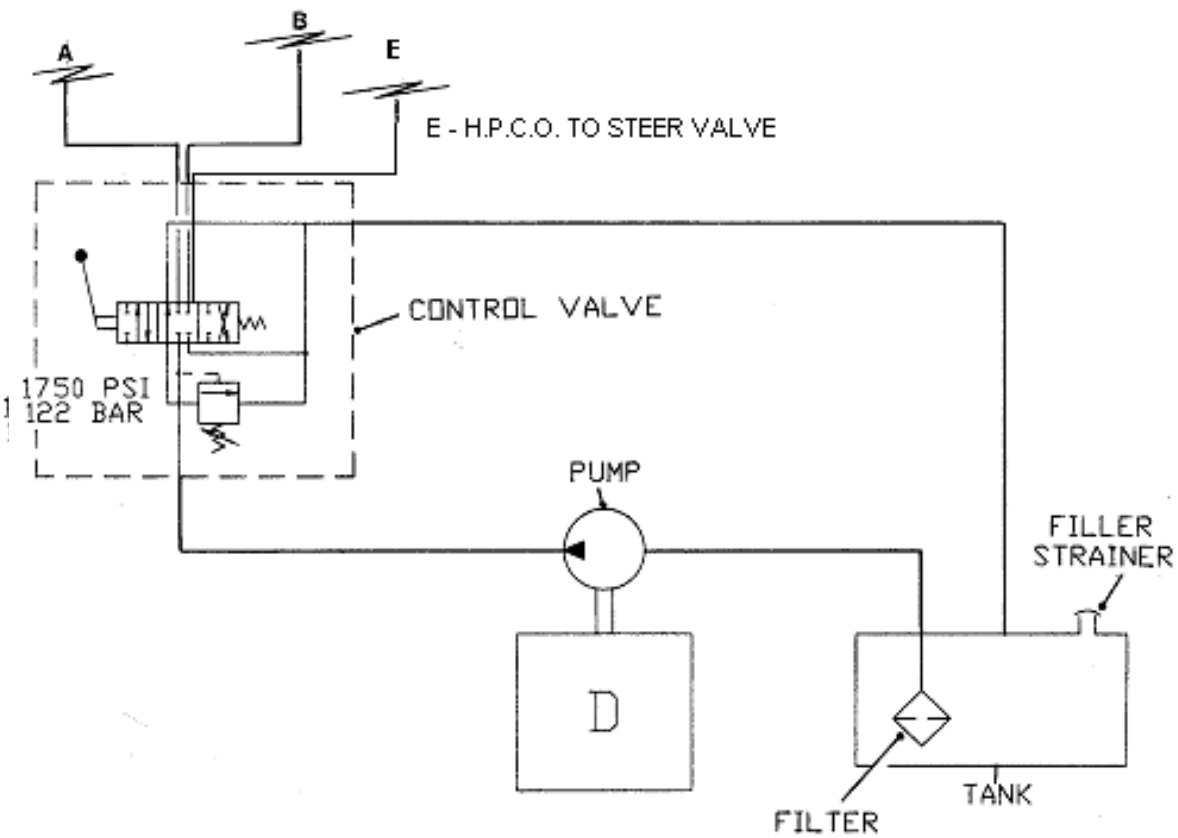
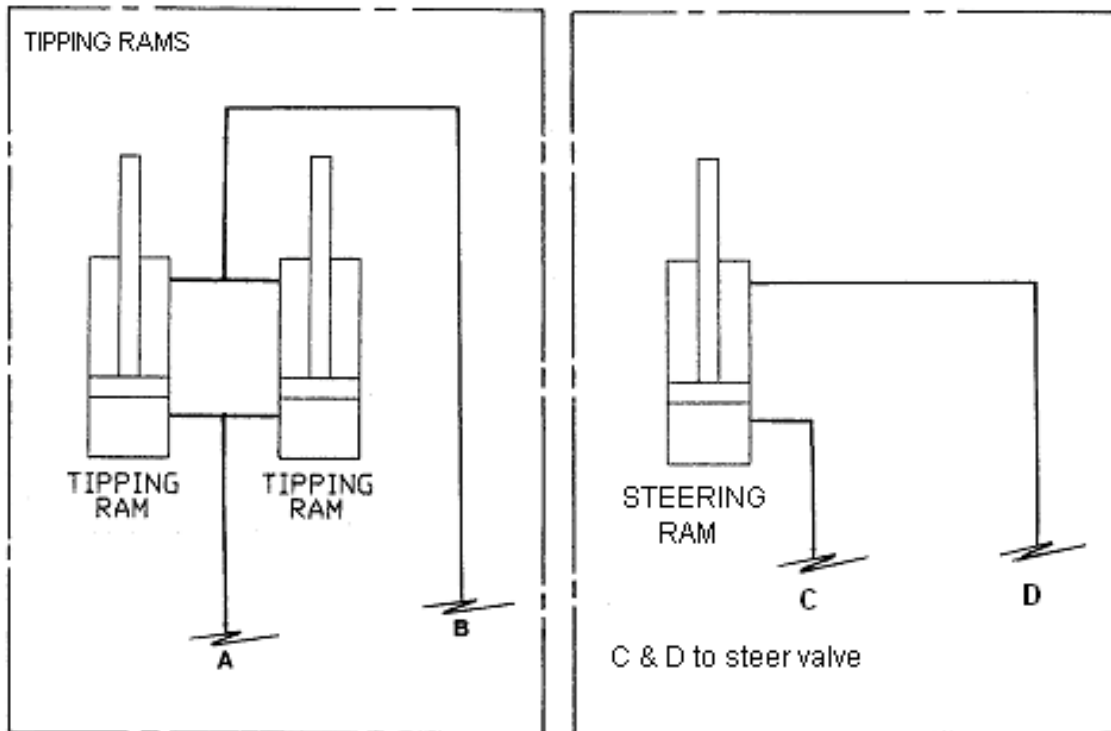

## HYDRAULIC SYSTEM

### Hydraulic System Checks

If the hydraulic system fails to operate completely, or does so extremely slowly, carry out the following procedure.

Check that the hydraulic tank is full of oil to the correct level. The level is correct when the cone at the base of the filler neck is visible.

Check that the filter has been regularly cleaned in accordance with the maintenance schedule. If not, clean filter.

Check that the hydraulic pressure is correct as follows:

#### HYDRAULIC TIP

Fit a 3000 lb/in<sup>2</sup> gauge into the hydraulic system at the base of the skip ram.

Operate control lever to tip skip and check the pressure reading on the gauge when ram is fully extended and relief valve is 'blowing'.

#### GRAVITY TIP

Fit a 3000 lb/in<sup>2</sup> gauge into the hydraulic circuit between the relief valve and the steer valve.

Turn the steering wheel to full lock and check the pressure reading on the gauge when full lock is reached and the relief valve is 'blowing'.

*See "Specifications" for correct pressure*

**If this procedure does correct the fault, contact your Distributor.**

Periodically check the supply hose between the pump and the hydraulic tank to ensure that it is not deformed. Any deformation in the hose may result in a restricted flow and damage to the pump.

### Every 10 operating hours, or daily Check hydraulic oil level

**Do not check oil level before closing the tipping rams, and the engine has been stopped for 2 minutes.**

The oil level **(A)** is correct when the cone **(B)** at the base of the filler neck is visible. Do not overfill; it will cause leakage from the breather!

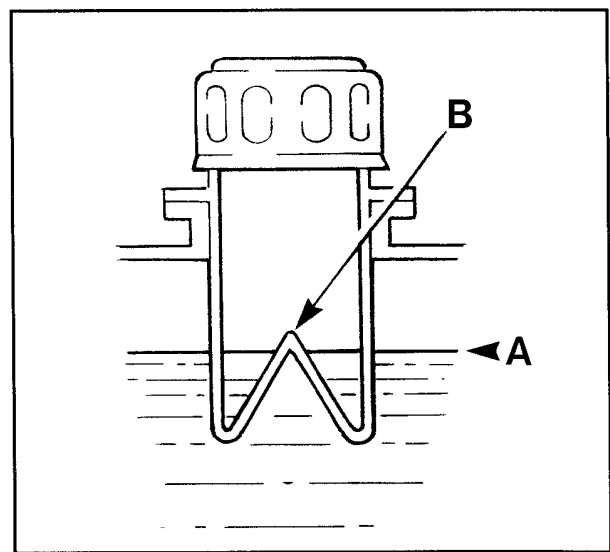

**First 100 operating hours****Clean / change hydraulic oil filter**

**WARNING** *Before cleaning filter, stop the engine and dump hydraulic pressure.*



Place a *clean* suitable container beneath the hydraulic tank filter. Clean the area surrounding the filter.

Carefully unscrew the filter (C) from the tank (D) allowing the oil to drain into the container.

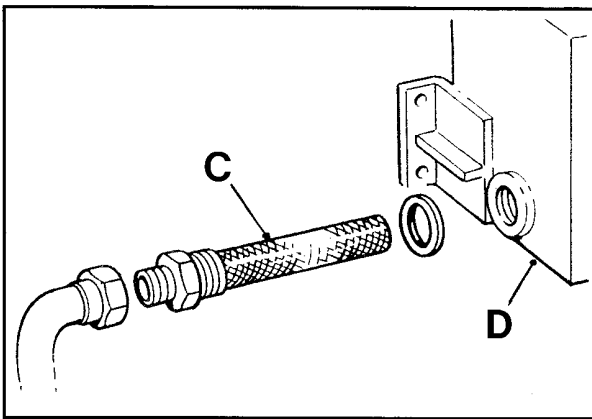

*Provided that the oil does not become contaminated it can be used to refill the tank after the filter has been cleaned and replaced*

Wash the filter in white spirit and check it for any damage. *If the filter cannot be thoroughly cleaned, fit a new one.*

Screw the filter back into the tank.

Fill tank with oil. (The oil level (A) is correct when the cone (B) at the base of the filler neck is visible.) For the correct type of oil, see "*Specifications*".

Run the engine to circulate the oil.

Operate the hydraulic control to purge any air from the system.

Stop the engine and top up the tank as required. Check the areas around the filter for leaks.

**Every 1000 operating hours****Clean / change hydraulic oil filter**

Clean or change the hydraulic oil filter, using the procedure described in the previous "*First 100 operating hours*".

**Every 1000 operating hours****Change hydraulic oil**

Run the engine and operate the hydraulics to warm the oil. Fully close the tipping rams.

Switch off the engine and dump hydraulic pressure.

Clean the area surrounding the hydraulic tank filter and filler cap.

Place a suitable container on the ground beneath the filter to catch oil.

**CAUTION:** Before removing the filter be sure to stand to one side to avoid the oil that will spill from the hole. Carefully remove the filter and drain the oil from the tank.

Flush out the tank with clean hydraulic oil, taking extreme care to remove all dirt and foreign matter.

Refit the filter.

Clean the filler cap breather.

Refill the tank with clean oil of the correct type and grade. For the correct type of oil, see "*Specifications*".

Run the engine to circulate the oil.

Operate the hydraulic control to purge any air from the system.

Stop the engine and top up the tank as required.

Check the area around the filter for leaks.



**DIMENSIONS**

<i>Earth skip</i>		<i>m</i>	<i>ft in</i>
<b>A</b>	Overall length	2.85	9' 4"
<b>B</b>	Overall width	1.64	5' 5"
<b>C</b>	Overall height	1.37	4' 6"
<b>D</b>	Skip discharge height	0.130	0' 5"
<b>E</b>	Skip loading height	1.17	3' 10"
<b>F</b>	Ground clearance	0.28	0' 11"
<b>G</b>	Track	1.37	4' 6"
<b>H</b>	Wheel base	1.66	5' 5"
<b>J</b>	Maximum skip height when tipped	1.47	4' 10"
<b>K</b>	Skip discharge forward of tyres	0.35	1' 2"
<b>L</b>	Skip discharge width	1.42	4' 8"
Articulation		0.29	0' 11½"
Turning circle		7.35	24' 1"

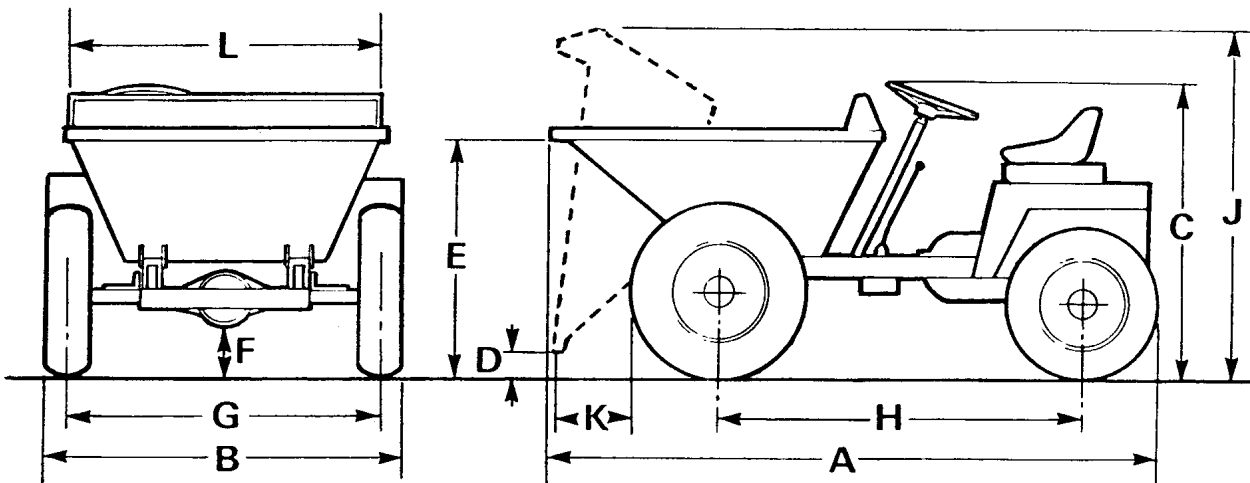

## SPECIFICATIONS

<b>ENGINE</b>	Lister-Petter TR1: Single cylinder, direct injection, naturally aspirated, flywheel fan air cooled diesel. Rotation: Anti-clockwise when looking on the flywheel. TR1: Power output: 6.7 kW (9.0 bhp) @ 1800 rev/min.
<b>ELECTRICS</b>	(Where fitted) 12 volt negative earth.
<b>FUEL</b>	System: Single element fuel pumps. Fuel specification: BS2869:1988 Class A2, or BS EN590:1995 Class A1. Fuel tank capacity: 8.25 litres Fuel filter: Strainer within fuel tank. Air cleaner: Renewable element.
<b>AXLES</b>	Front: Heavy duty with fully floating half shafts. Rear: Centrally pivoted steer axle (without brakes).
<b>BRAKE</b>	Service: Front axle braking. Totally sealed oil immersed multi-plate disc brakes, featuring fully automatic adjustment for wear. Parking: Hand operated, ratchet type, actuating disc brake on transmission.
<b>TRANSMISSION</b>	Heavy duty constant mesh gearbox, with 3 forward and 1 reverse gear.
<b>HYDRAULICS</b>	Pump: Gear type. Control valve: Monobloc with pressure relief valve. Filter: Suction strainer mounted within the hydraulic tank.

## VIBRATION DECLARATION

Whole body vibration level  $a_w$  (m/s<sup>2</sup>) :- 0.7 - 0.8 Typical\*

**\*Note:** *The absence of a harmonised test code together with the variable conditions under which this equipment may be used allows only representative figures to be quoted.*

Hand/arm vibration level  $a_{ha}$  (m/s<sup>2</sup>) :- Less than 2.5

## SPECIFICATIONS

### ROAD SPEEDS *with engine at 1800 rev/min*

1st Gear		2nd Gear		3rd Gear		Reverse	
km/h	(mph)	km/h	(mph)	km/h	(mph)	km/h	(mph)
4.1	(2.6)	9.1	(5.75)	15.7	(9.8)	4.3	(2.6)

### LUBRICANTS AND FLUIDS Total oils (factory fill)

### Capacities

Engine Lub. Oil	Rubia H 10W/40	2.7 litres
<i>Note: For engine oils used in temperatures above 30 deg. C consult the Engine Handbook</i>		
Gearbox	Rubia B 20W/30	2.0 litres (approx)
Front axle	Universal plant oil or Transmission MP	3.5 litres
Hydraulic system	Azzola ZS46	27.3 litres (tank)
Braking system	Azzola ZS22	0.3 litres (approx)
General grease	Multis EP 2	as required
General lubrication oil	Rubia B 20W/30	as required

### TYRE PRESSURES

Front	2.35 bar	(35 lb in <sup>2</sup> )
Rear	2.35 bar	(35 lb in <sup>2</sup> )

### ADJUSTMENTS

Wheel nuts torque	200 lbf ft	(271 Nm)
Engine	<i>(see Engine Workshop Manual)</i>	

### TYRES

Front	7.50 x 16 traction
Rear	6.00 x 16 ribbed

### DRAWBAR LOAD

Weight on drawbar	500 N	(50 kg)
Drawbar pull	2500 N	(250 kg)

### NOISE LEVELS

TR1 engine	94 LPA	107 LWA
------------	--------	---------

### HYDRAULIC PRESSURE

	120.7 bar	(1750 psi)
--	-----------	------------

### PAYLOAD & CAPACITIES

Payload	1500 kg (4410 lbs)
Water level	700 litres (24.7 ft <sup>3</sup> )
Struck	700 litres (24.7 ft <sup>3</sup> )
Heaped	973 litres (34.3 ft <sup>3</sup> )

### MACHINE WEIGHTS

Unladen GT	940 kg	(2068 lbs)
Unladen HT	980 kg	(2156 lbs)

MAIN ELECTRICAL CIRCUIT (without road lights)

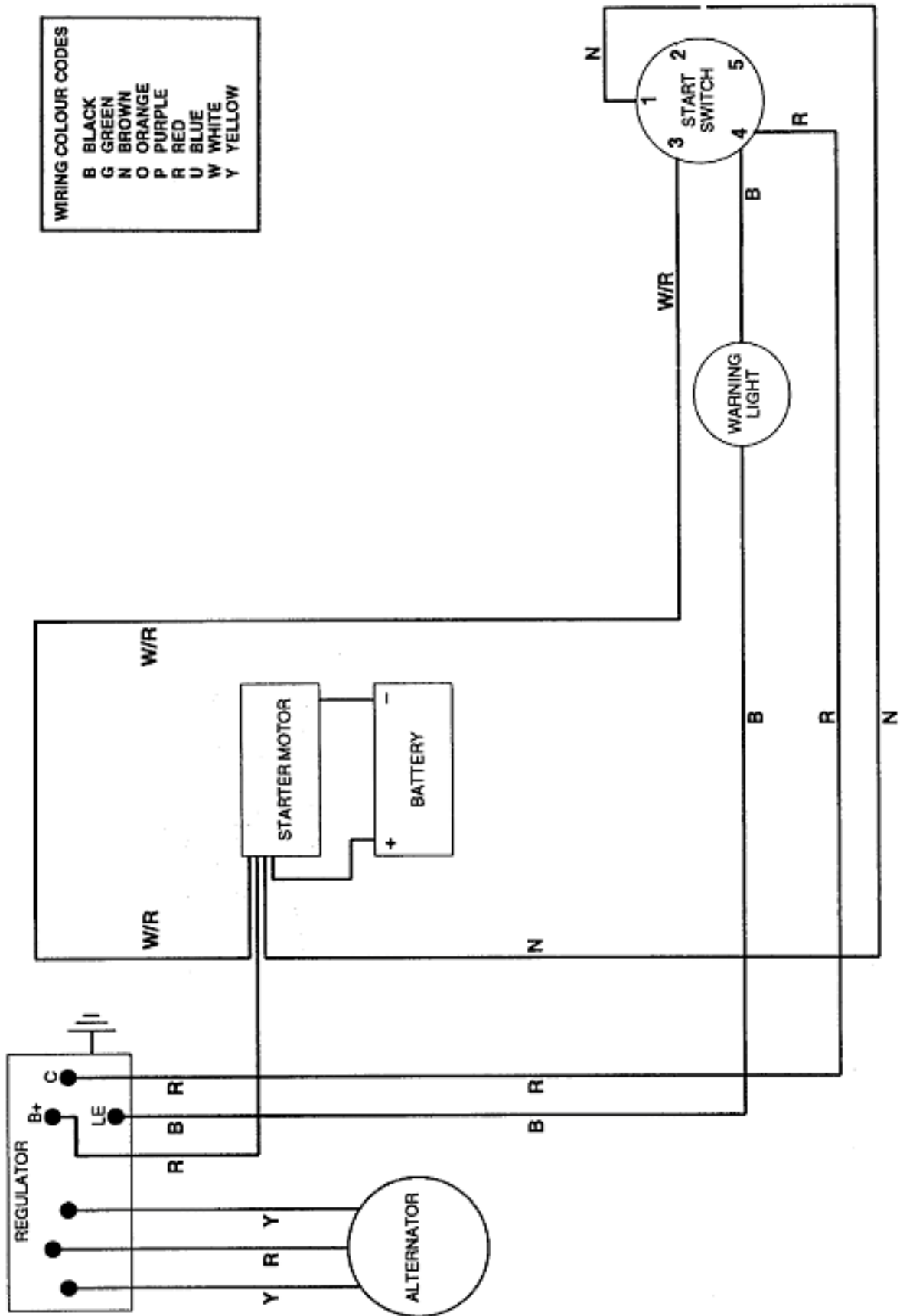

WIRING COLOUR CODES

B	BLACK
G	GREEN
N	BROWN
O	ORANGE
P	PURPLE
R	RED
U	BLUE
W	WHITE
Y	YELLOW

ROAD LIGHTS ELECTRICAL CIRCUIT

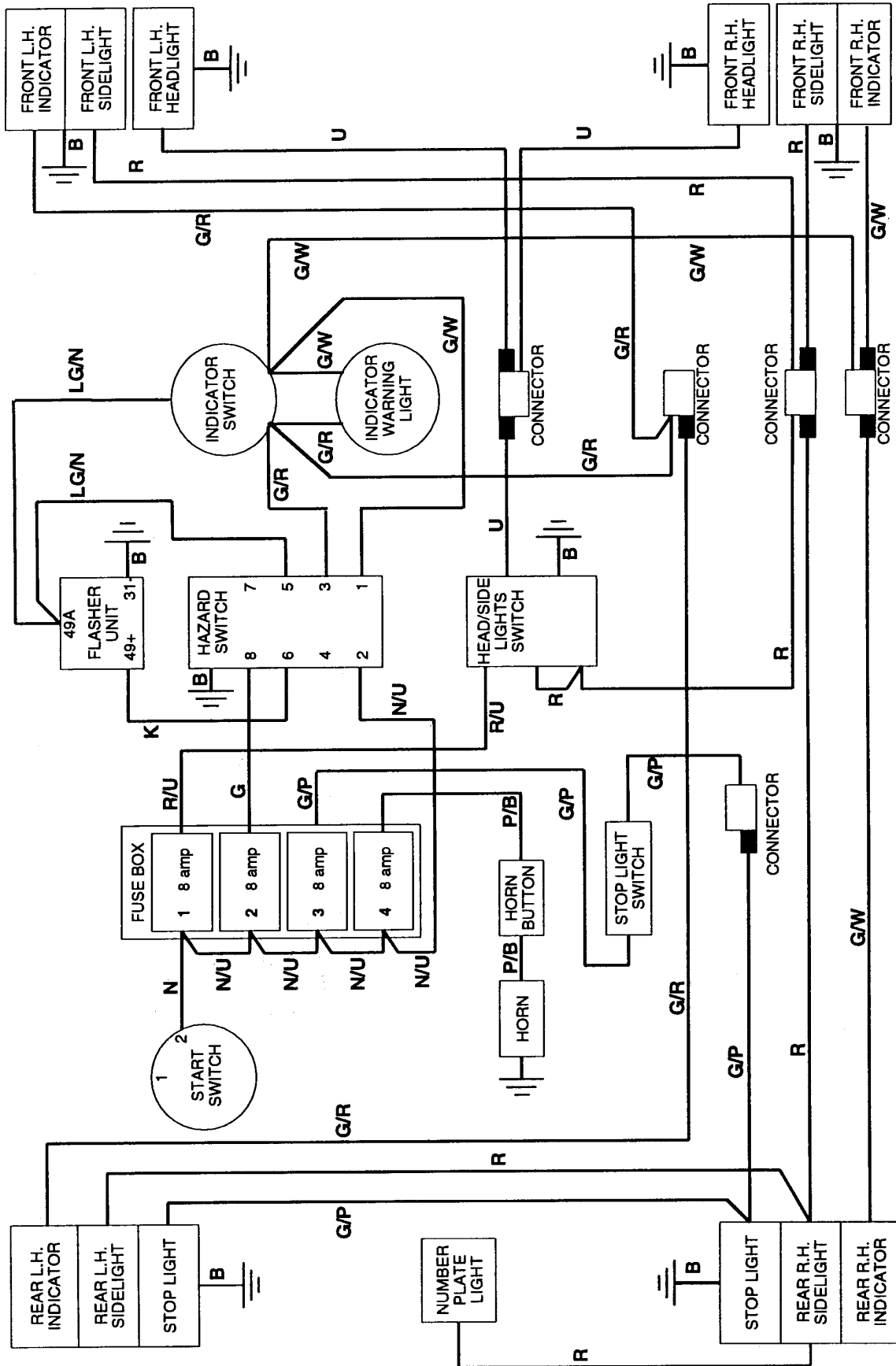



# 2B1500 DUMPERS

## PARTS

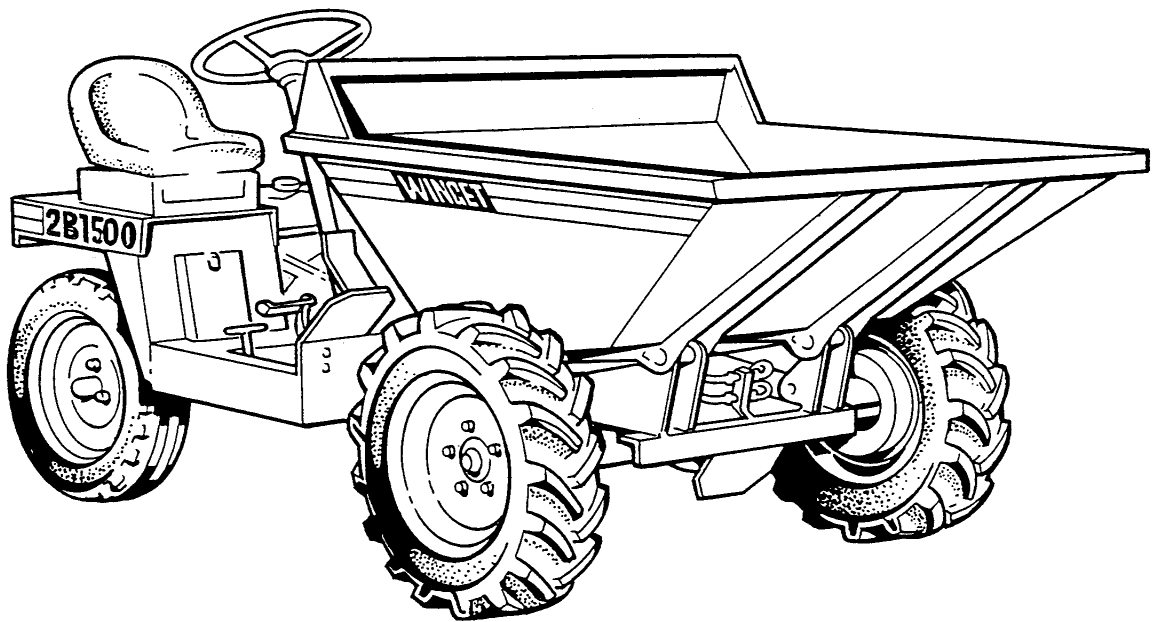





# ***Contents***

- A CHASSIS & SKIPS**
- B AXLES & STEERING**
- C TRANSMISSIONS**
- D BRAKES**
- E ENGINES**
- F ELECTRICS**
- H HYDRAULICS**
- J DECALS**



# 2B1500 DUMPER

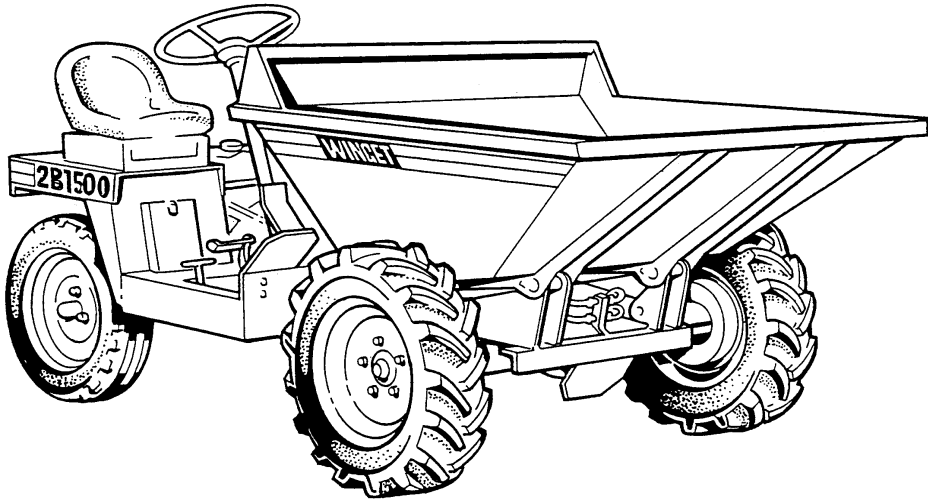



# ***Chassis, Panels & Skips***

**CHASSIS**

---

**A - 1**

**BATTERY TRAY**

---

**A - 1B**

**SEAT "KAB" (*To ISO 6683*)**

---

**A - 1D**

**R.O.P.S. FRAME**

---

**A - 1E**

**SKIPS**

**Gravity tip**

---

**A - 2**

**Hydraulic tip**

---

**A - 3**

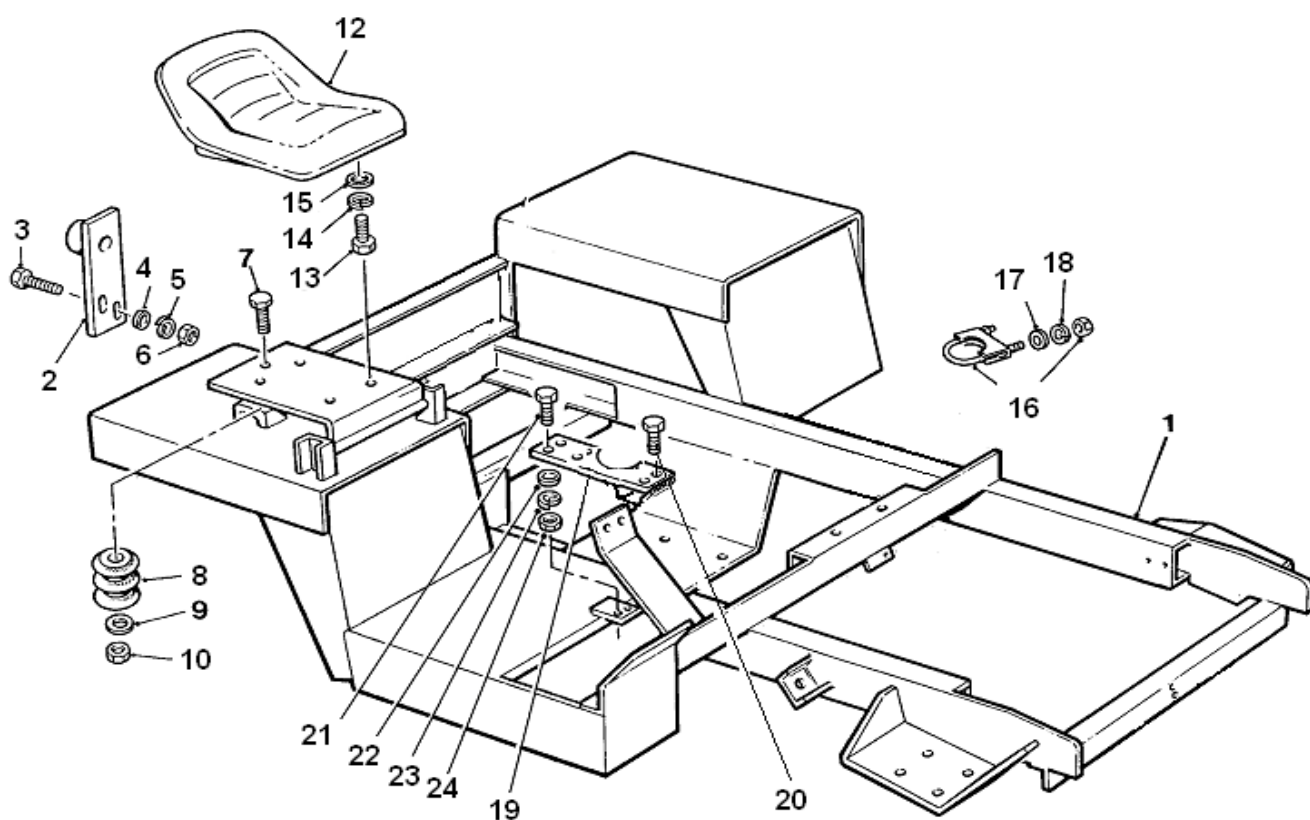

**CHASSIS & FITTINGS****A - 1**

<b>Item</b>	<b>Part no</b>	<b>Serial no</b>	<b>Description</b>	<b>Qty</b>
1	40286A01		CHASSIS	1
2	20355A04		BRACKET, starting handle support	1
3	11S04E		SCREW	2
4	267S06		WASHER, flat	4
5	17S05		WASHER, spring	2
6	7S04		NUT	2
7	11S04E		SCREW, set	1
8	10519A01		SPRING, seat mounting	1
9	V2004220		WASHER, special	1
10	59S03		NUT, nyloc	1
12	V2000954		SEAT, cushioned	1
13	11S03B		SCREW, set	4
14	17S04		WASHER, spring	4
15	267S05		WASHER, flat	4
16	153S05		"U" BOLT, c/w nuts <i>discard clamp</i>	1
17	267S05		WASHER, flat	2
18	17S04		WASHER, spring	2
19	V2006339		BRACKET, steer valve mounting	1
20	8S04K		BOLT	2
21	11S04D		SCREW, set	2
22	17S05		WASHER, spring	4
23	267S06		WASHER, flat	4
24	7S04		NUT	4

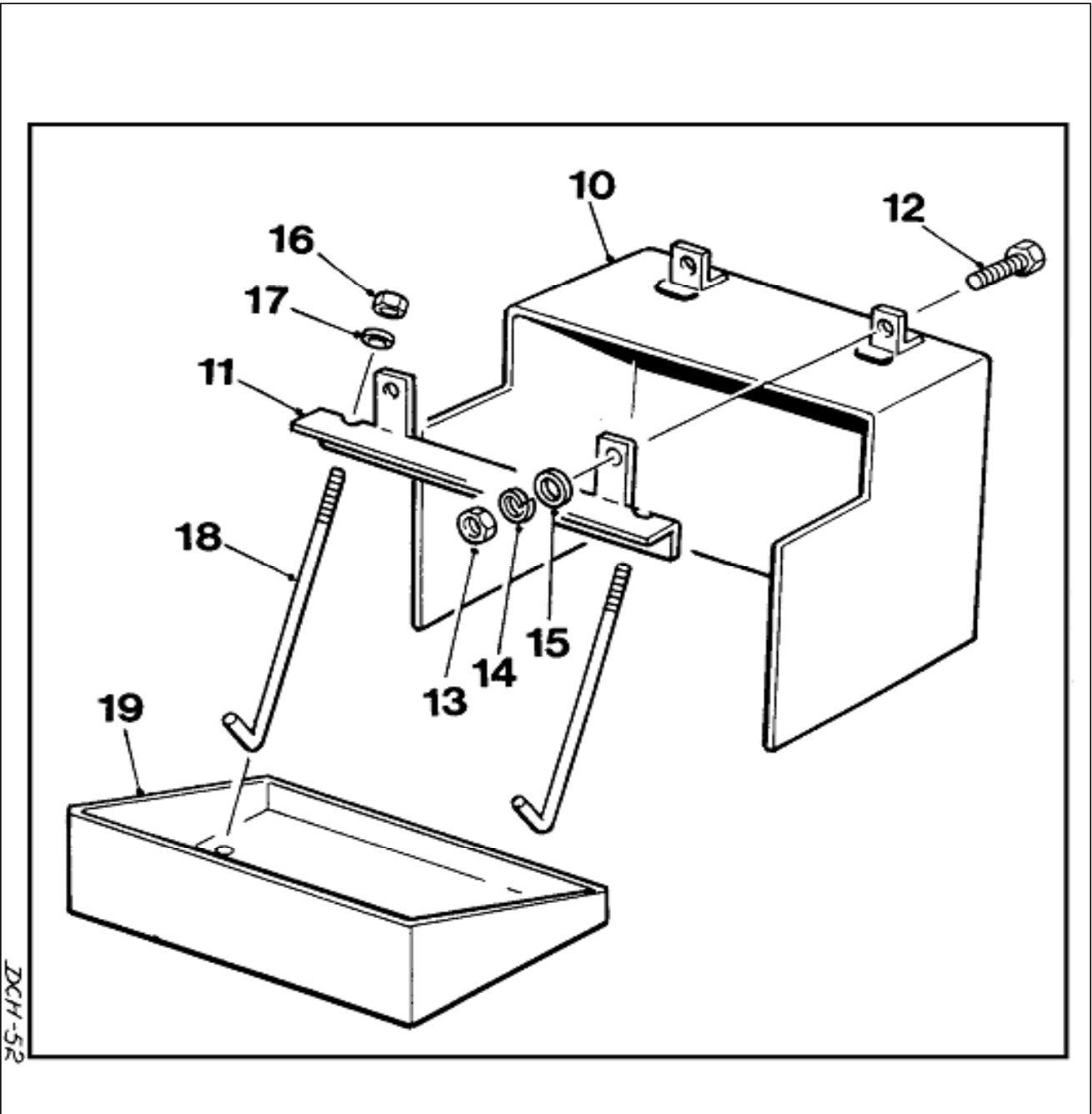



**BATTERY TRAY****A - 1B**

<b>Item</b>	<b>Part no</b>	<b>Serial no</b>	<b>Description</b>	<b>Qty</b>
10	513358600		COVER, battery	1
11	V2004055		CLAMP, battery	1
12	11S04C		SCREW,set	2
13	7S04		NUT	2
14	17S05		WASHER, spring	2
15	267S06		WASHER, flat	2
16	61S02		NUT	2
17	267S04		WASHER, flat	2
18	V2004120		ROD, clamp	2
19	513358500		TRAY, battery. ( <i>welded to chassis</i> )	1

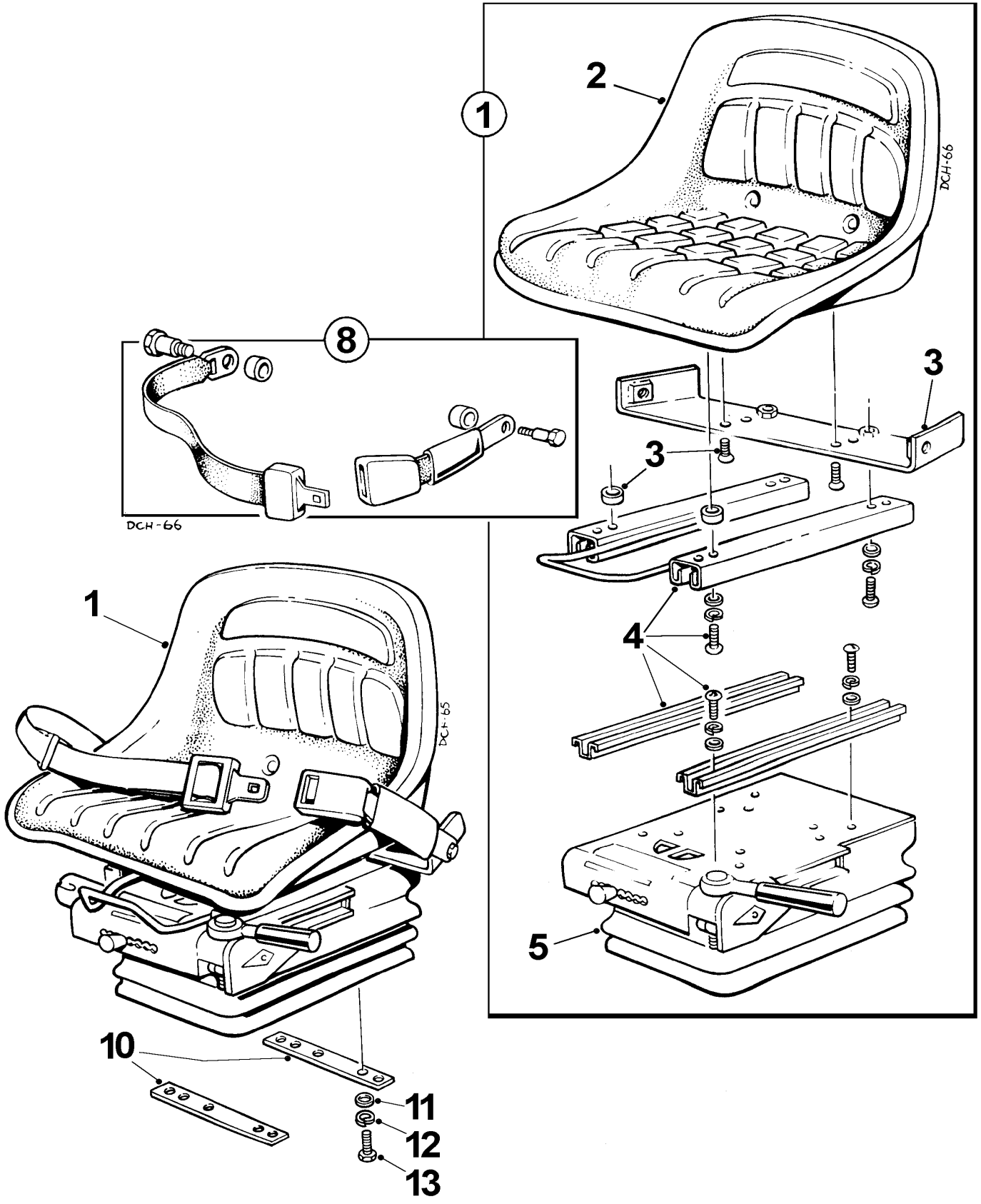

Item	Part no	Serial no	Description	Qty
<b><i>This seat and belt must be used with R.O.P.S. kits (see pages A-1E and A-1F)</i></b>				
1	V2005013		SEAT, assembly c/w with seat belt	1
2	V2000954		SEAT, 'KAB P2N'	
3	V602750		BRACKET, anchorage	1
4	V602752		SLIDE RAIL, assembly	1
5	V602751		UNIT, suspension 'XH2' (ISO 6683)	1
8	V602749		BELT, seat	1
10	V2004206		PLATE, clamp	2
11	267S05		WASHER, flat	4
12	17S04		WASHER, spring	4
13	11S03C		SCREW, set	4

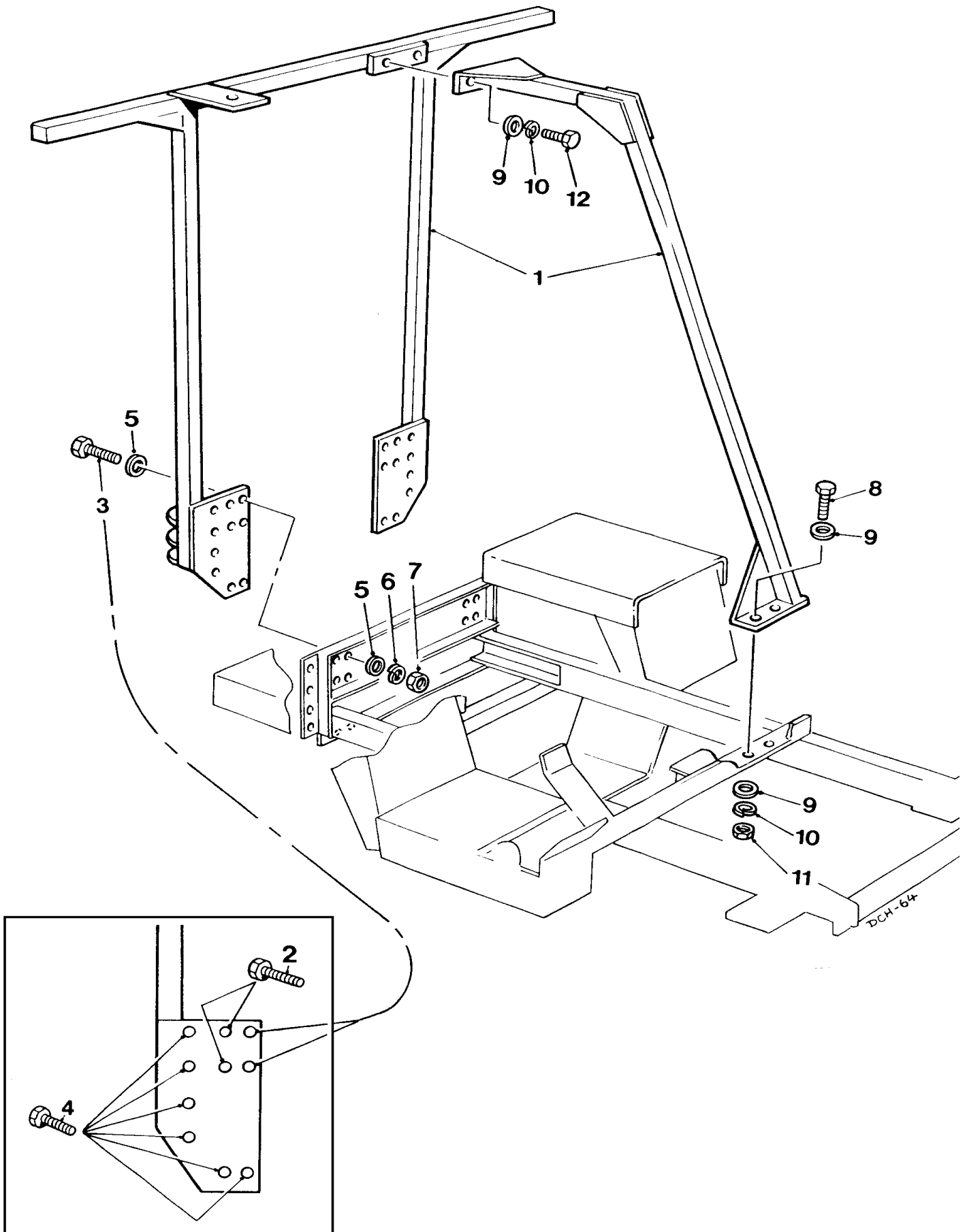

**R.O.P.S. FRAME****A - 1E**

Item	Part no	Serial no	Description	Qty
.....	V602747		# R.O.P.S. KIT, <i>includes items 1 to 12 below plus KAB XH2/P2N seat assembly with seat belt to ISO 6683. (See page A-1D)</i>	
1	V2004946		FRAME, R.O.P.S.	1
2	11S04G		SCREW, set	4
3	11S04E		SCREW, set	4
4	11S04F		SCREW, set	12
5	267S06		WASHER, flat	40
6	17S05		WASHER, spring	20
7	7S04		NUT	20
8	11S05G		SCREW, set	2
9	267S07		WASHER, flat	6
10	17S06		WASHER, spring	4
11	7S05		NUT	2
12	11S05C		SCREW, set	2

# *To fit kit refer to Service Bulletin SB226*

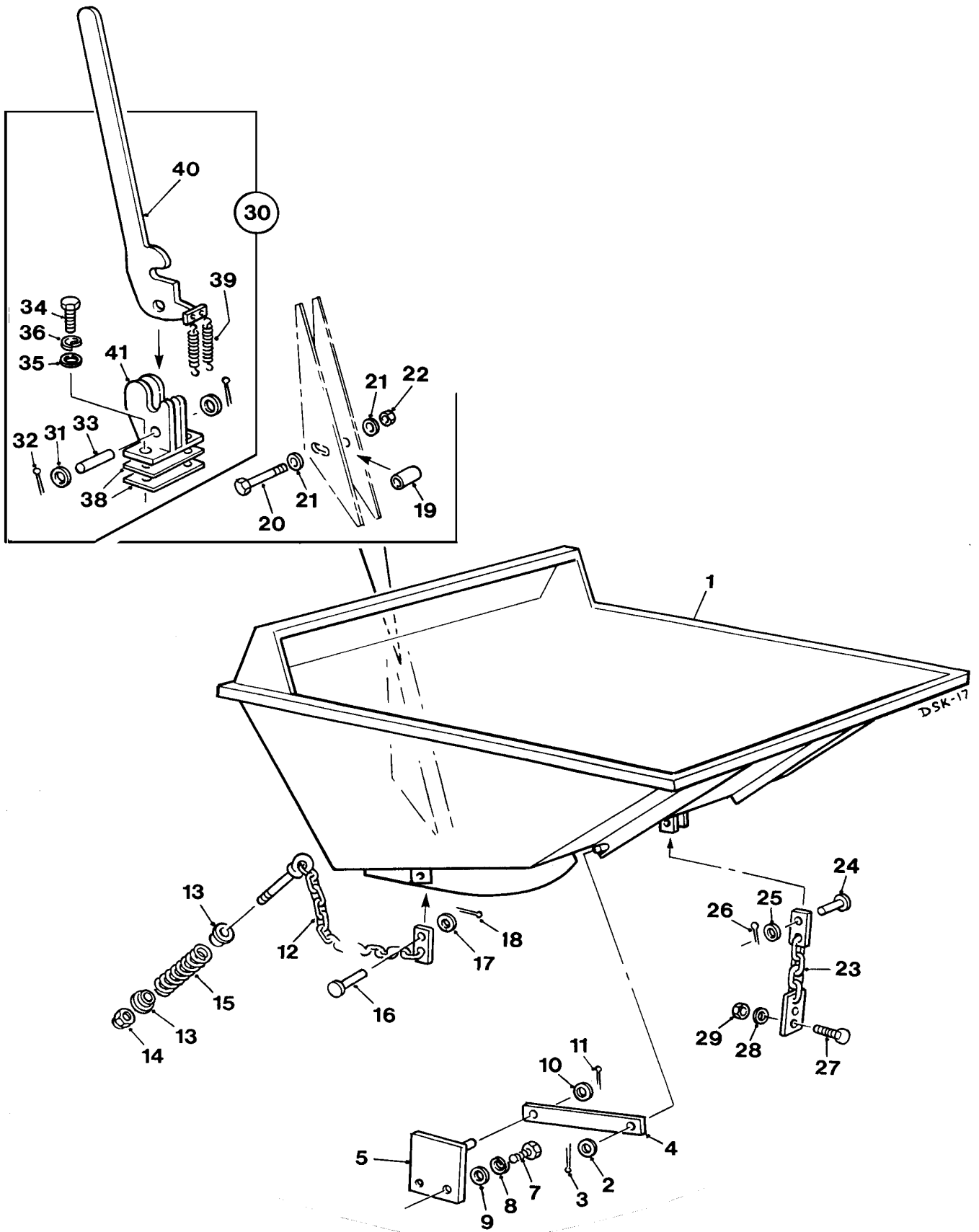

Item	Part no	Serial no	Description	Qty
1	40295A04		SKIP, gravity tip	1
2	10S06		WASHER, flat	2
3	44S05G		PIN, split	2
4	10892A01		ARM, radius	2
5	10893A01		BRACKET, mount, R.H. ( <i>illustrated</i> )	1
.....	10893A02		BRACKET, mount, L.H. ( <i>not illustrated</i> )	1
7	11S05E		SCREW, set	4
8	17S06		WASHER, spring	4
9	267S07		WASHER, flat	4
10	10S06		WASHER	2
11	44S05G		PIN, split	2
12	20286A10		CHAIN, skip check, c/w bolt	2
13	10894A02		COLLAR, spring alignment	4
14	59S04		NUT, nylon insert	2
15	C173A		SPRING, compression	2
16	10650A04		PIN, clevis	2
17	10S04		WASHER	2
18	44S03C		PIN, split	2
19	C140A		TUBE, skip catch	1
20	8S06R		BOLT	1
21	247S09		WASHER, flat	2
22	59S11		NUT, nylon insert	1
23	20286A02		CHAIN, front	1
24	10650A18		PIN, clevis	1
25	10S03		WASHER, flat	1
26	44S02C		PIN, split	1
27	11S03C		SCREW, set	2
28	17S04		WASHER, spring	2
29	7S03		NUT	2
30	40296A01		CATCH, skip, assembly	1
31	10S06		WASHER, flat	2
32	44S04E		PIN, split	2
33	40296A0105		PIN, pivot	1
34	11S06G		SCREW, set	2
35	267S09		WASHER, flat	2
36	17S08		WASHER, spring	2
38	10054A04		SHIM	AR
39	C173B		SPRING	2
40	10912A03		LEVER, catch	1
41	-----		BODY, catch ( <i>order assembly</i> )	1

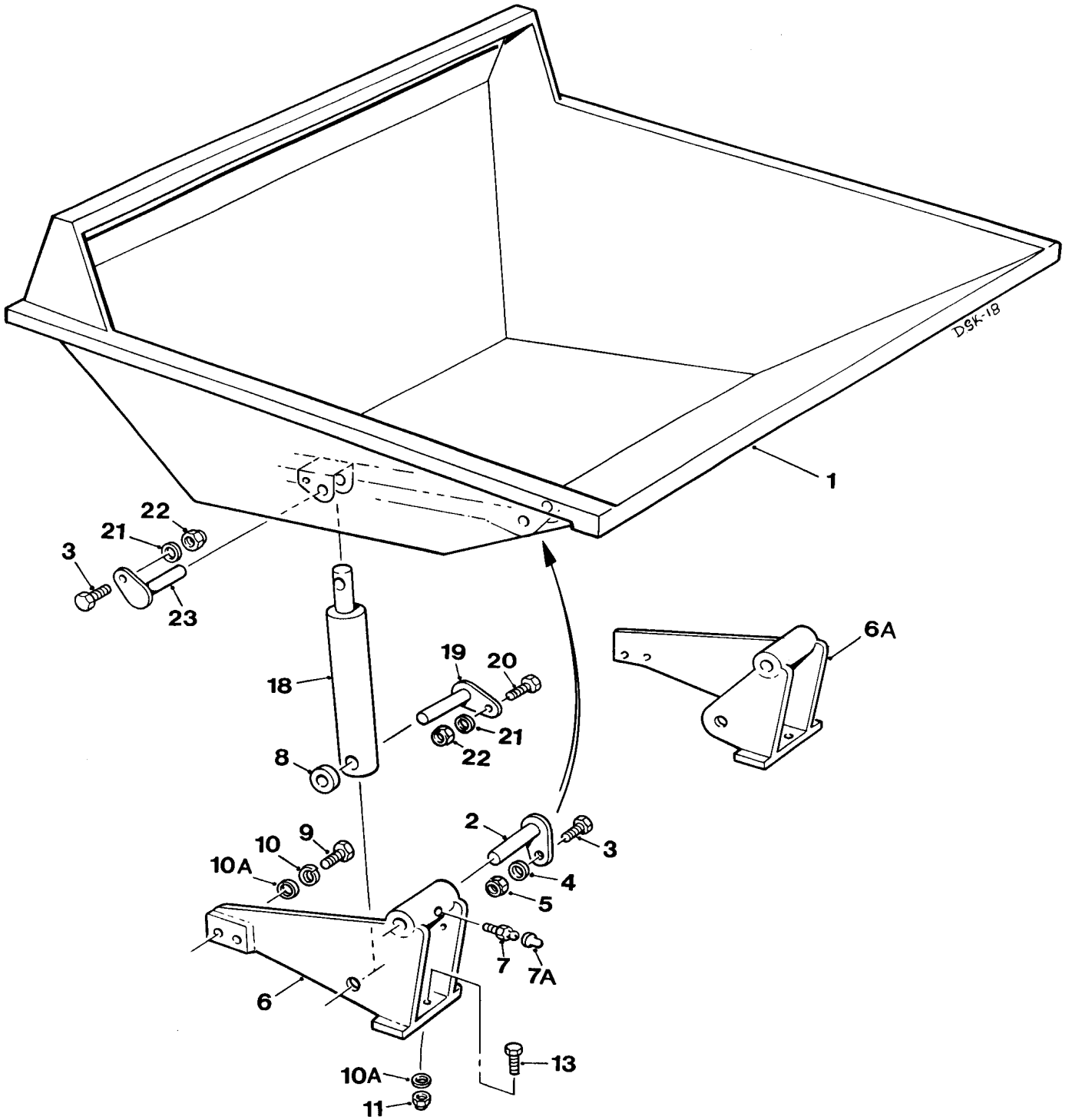



Item	Part no	Serial no	Description	Qty
1	40295A05		SKIP, hydraulic tip	1
2	10470A10		PIN, pivot, skip	2
3	11S04C		SCREW, set	4
4	267S06		WASHER, flat	2
5	59S03		NUT, nylon insert	2
6	30126A08		BRACKET, pivot, R.H. ( <i>illustrated</i> )	1
6A	30126A09		BRACKET, pivot, L.H. ( <i>not illustrated</i> )	1
7	131S01		NIPPLE, grease	2
7A	176S01		CAP, grease nipple	2
8	L2791		SPACER	2
9	8S05E		BOLT	4
10	17S06		WASHER, spring	4
10A	267S07		WASHER, flat	6
11	59S04		NUT, nylon insert	2
13	11S05E		SCREW, set	2
18	-		RAM, hyd ( <i>see page H - 5</i> )	2
19	10470A11		PIN, pivot	2
20	11S04C		SCREW, set	2
21	267S06		WASHER, flat	4
22	59S03		NUT, nylon insert	4
23	10470A12		PIN, pivot	2



# 2B1500 DUMPER

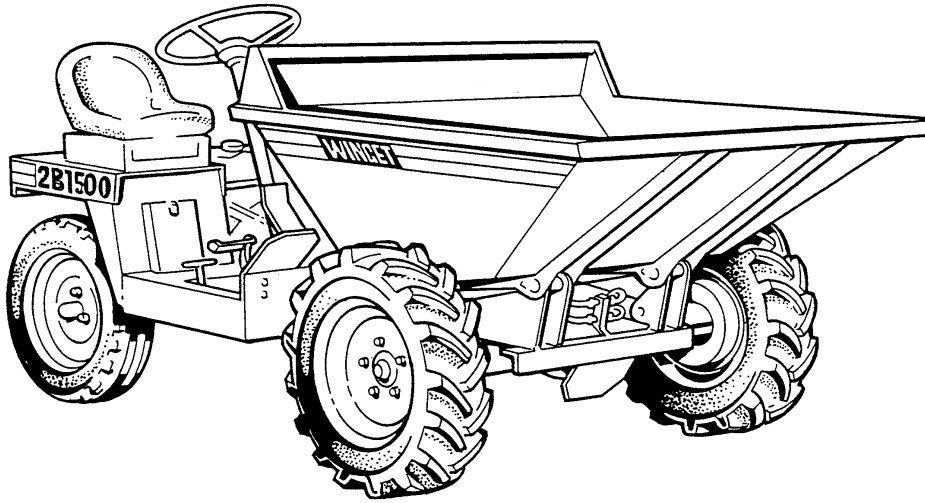



# ***Axles & Wheels***

**WHEELS & TYRES** **B - 1**

---

**DRIVE AXLE, Newage & fittings** **B - 2**

---

**DRIVE AXLE, Newage, 215 series**

**Input pinion & differential** **B - 2A**

**Planet carrier & axle casing** **B - 2B**

**Hub & axle shaft** **B - 2C**

**Brakes** **B - 2D**

---

**STEERING AXLE & STEERING RAM** **B - 3**

---

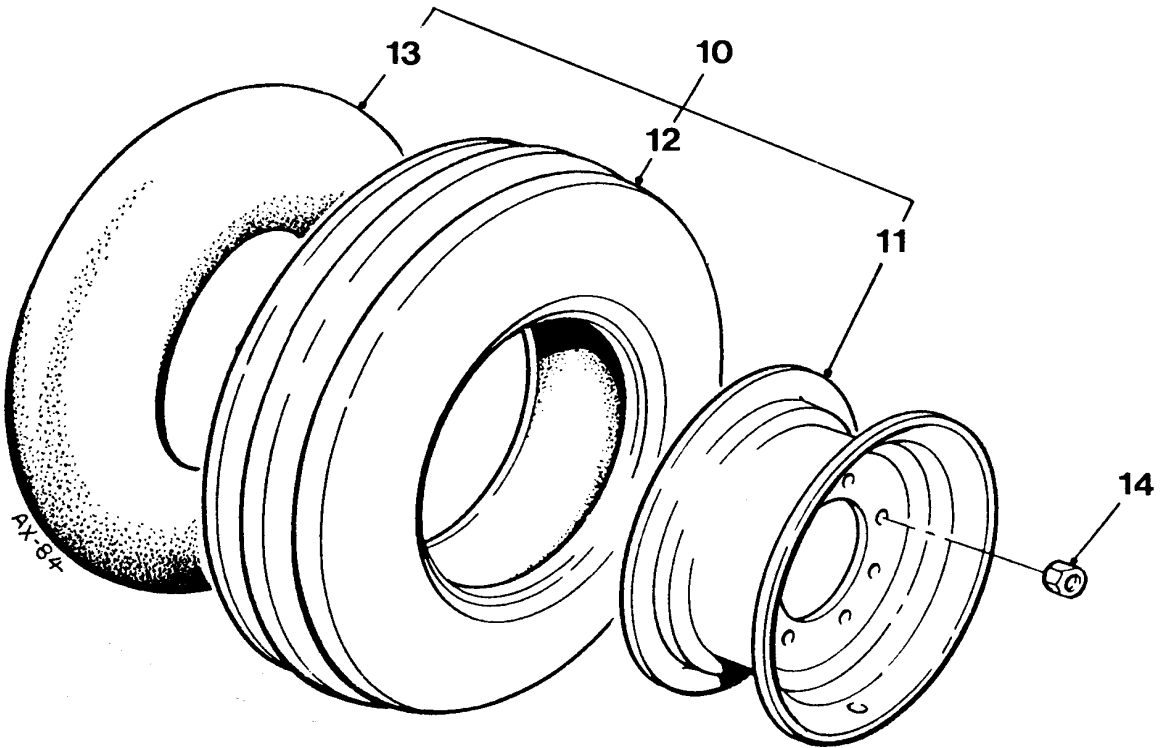
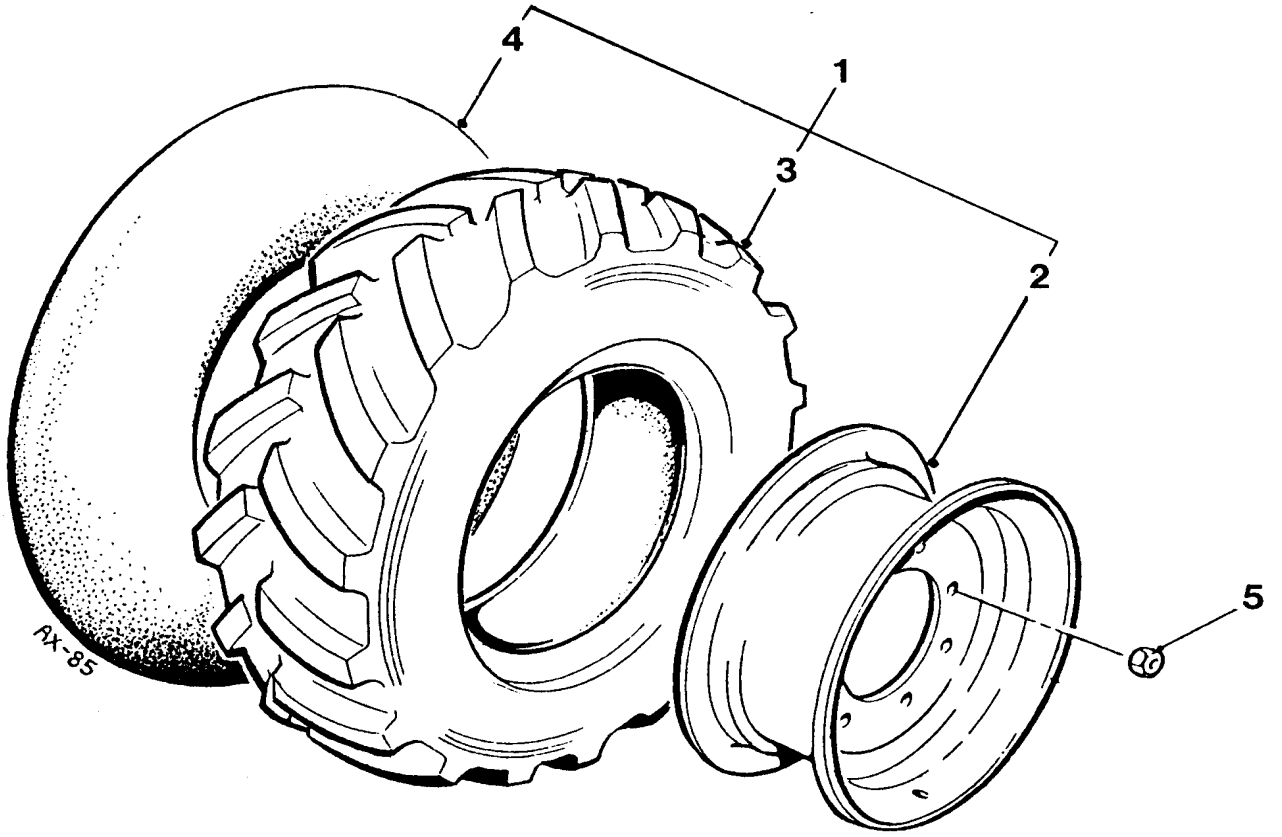

Item	Part no	Serial no	Description	Qty
------	---------	-----------	-------------	-----

**Check rim & tyre size before ordering.**

### FRONT

1	24S57		WHEEL, front, L.H., assembly	1
1	24S58		WHEEL, front, R.H., assembly	1
2	30192A03		RIM, wheel, 5.5 x 16	1
3	22S09		TYRE, 7.50 x 16	1
4	23S03		TUBE, 7.50 x 16	1
5	10668A01		NUT, wheel	10

### REAR

10	475600019		WHEEL, rear, assembly, 6.00 X 19	2
11	V602680		RIM, wheel, 16"	1
12	475600017		TYRE, 6.00 x 16	1
13	475600018		TUBE, inner	1
14	V602678		NUT, wheel	10

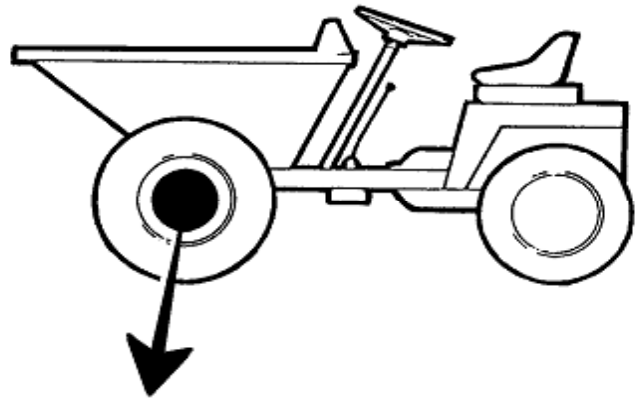

215

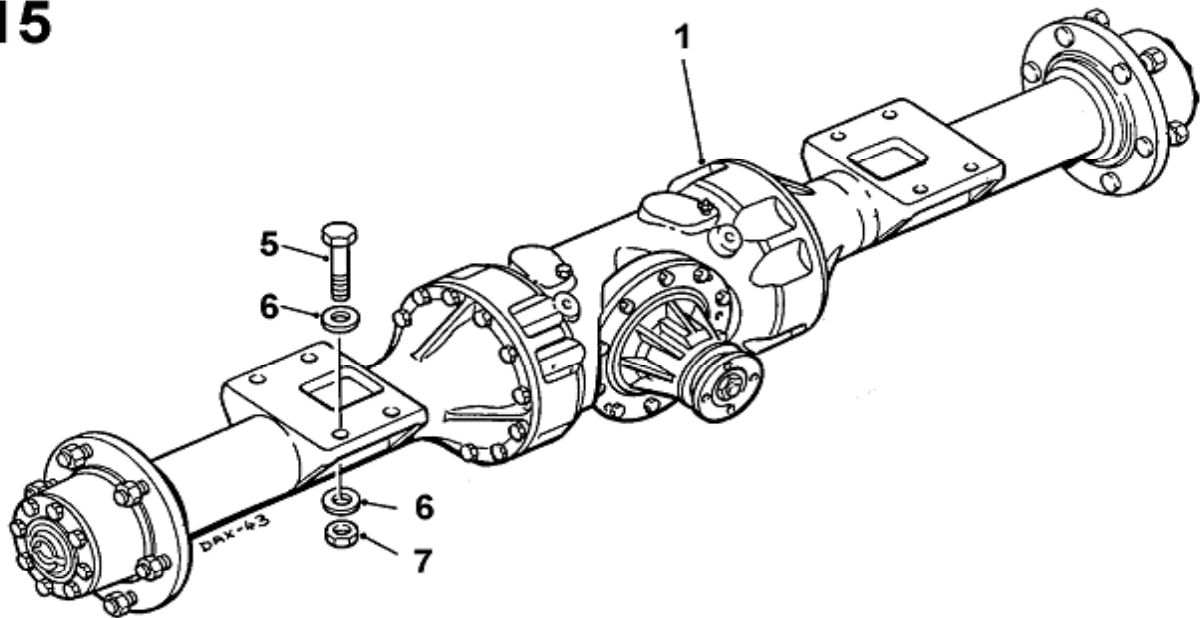



# FRONT DRIVE AXLE ( Newage 215) & FIXINGS

**B - 2**

Item	Part no	Serial no	Description	Qty
<b>2B1500</b>				
1	30156A13		<b>AXLE, 215</b> <i>(See page B-2A for Input pinion &amp; differential)</i> <i>(See page B-2B for planet carrier &amp; axle casing)</i> <i>(See page B-2C for hub &amp; axle shaft)</i> <i>(See page B-2D for brakes)</i>	1
5	8S06G		BOLT	8
6	267S09		WASHER, flat	16
7	59S11		NUT, "Nyloc"	8
				8
				8

215 series

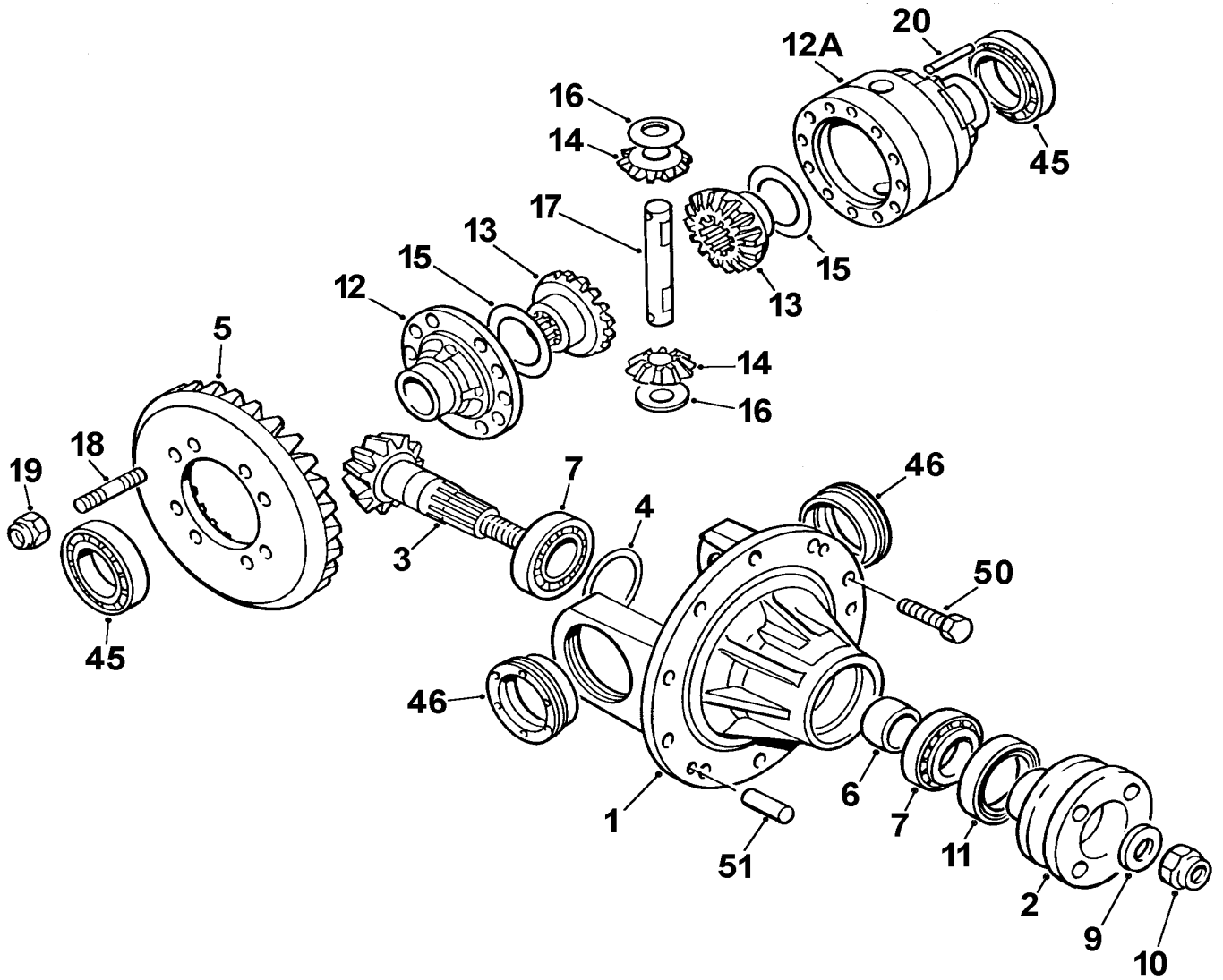

**INPUT PINION & DIFFERENTIAL**  
**Newage 215 series drive axle**

**B - 2A**

Item	Part no	Serial no	Description	Qty
1	30082A0401		PINION, input cartridge	1
2	30082A0402		FLANGE, input drive, c/w seal shield	1
3	30082A0403		PINION, spiral bevel	1
4	30082A0282		SHIM, 0.25mm	2
....	30082A0280		SHIM, 0.3mm	2
....	30082A0281		SHIM, 0.4mm	2
5	30082A0403		WHEEL, spiral bevel	1
6	30082A0235		SPACER	1
7	30082A0234		BEARING, cup & cone assembly	2
....	30082A0274		BEARING, cup	1
....	30082A0273		BEARING, cone	1
9	30082A0231		WASHER, plain	1
10	30082A0232		NUT	1
11	30082A0236		SEAL, oil	2
12	30082A0404		COVER, differential	1
12A	30082A0405		CASING, differential	1
13	30082A0283		WHEEL, differential	2
14	30082A0284		PINION, differential	2
15	30082A0241		WASHER, thrust	2
16	30082A0242		WASHER, thrust	2
17	30082A0303		SPIDER, differential, (half)	1
18	30082A0406		STUD	8
19	59S03		NUT, 'Nyloc'	8
20	30082A0306		PIN, Spirol	2
45	119325000		BEARING, cup & cone assy.	2
46	30082A0416		NUT, bearing adjustment	2
50	8S04B		BOLT	34
51	30156A0112		DOWEL, 10dia x 20mm	2

215 series

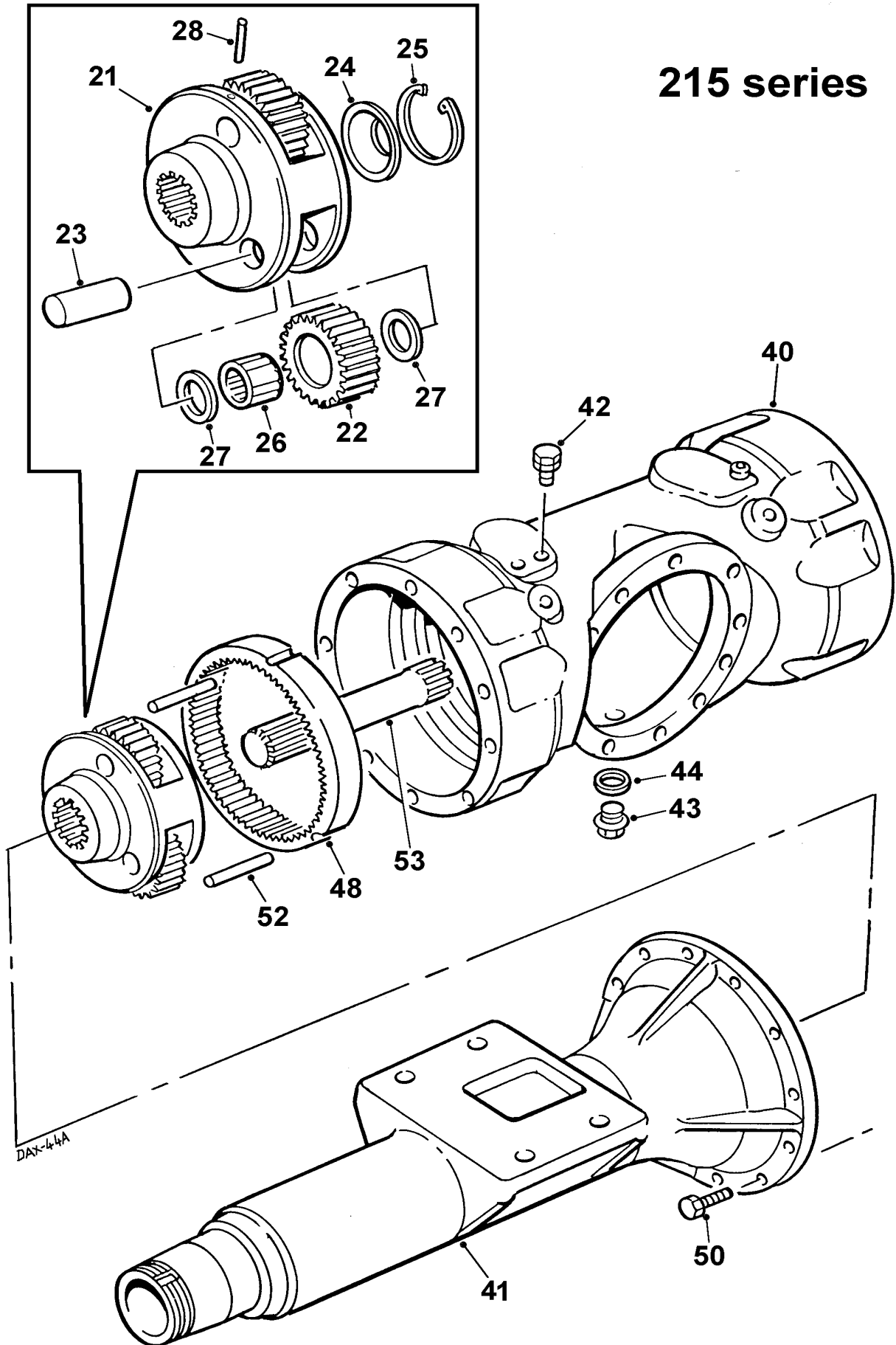

**PLANET CARRIER & AXLE CASING****B - 2B****Newage 215 series drive axle**

<b>Item</b>	<b>Part no</b>	<b>Serial no</b>	<b>Description</b>	<b>Qty</b>
21	30156A0802		CARRIER, planet	1
22	30156A0803		GEAR, planet	3
23	30156A0804		PIN, planet	3
24	30156A0805		SPACER	1
25	30082A0265		CIRCLIP	1
26	30082A0289		BEARING, needle	3
27	30082A0249		WASHER, thrust	6
28	30156A0162		DOWEL, spring	3
40	30082A0413		CASING, main	1
41	30082A0414		ARM, axle (1475mm)	2
42	30082A0415		BREATHER	1
43	30097A0163		PLUG, drain	2
44	100S04		SEAL, bonded	2
48	30156A0202		ANNULUS	2
50	8S04B		BOLT	34
52	30156A0102		DOWEL, 8dia x 60mm	4
53	30082A0418		GEAR, sun	2

215 series

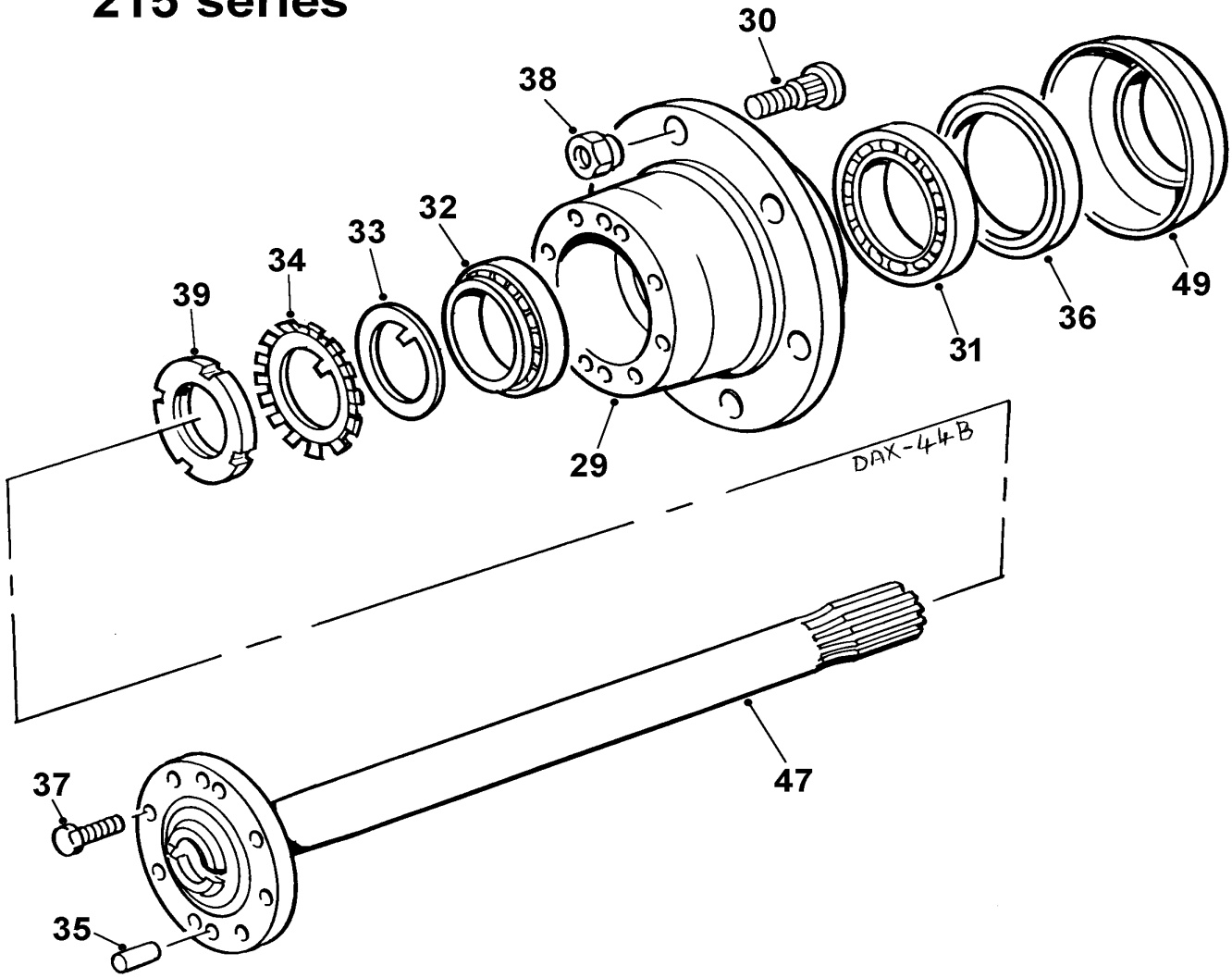

**HUB & AXLE SHAFT**  
**Newage 215 series drive axle**

**B - 2C**

Item	Part no	Serial no	Description	Qty
29	30082A0407		HUB	1
30	30156A0122		STUD, wheel	5
31	30082A0408		BEARING	1
32	30082A0409		BEARING	1
33	30082A0222		SPACER	1
34	30347A0201		LOCKWASHER	1
35	30156A0112		DOWEL, spring	2
36	30082A0410		SEAL, oil	1
37	8S04B		BOLT	8
38	.....		NUT, wheel (see " <i>Wheels</i> ", page B-1)	....
39	30082A0411		LOCKNUT	1
47	30082A0417		SHAFT, axle (1475mm)	2
49	30082A0422		COVER, seal, wheel hub	2

215 series

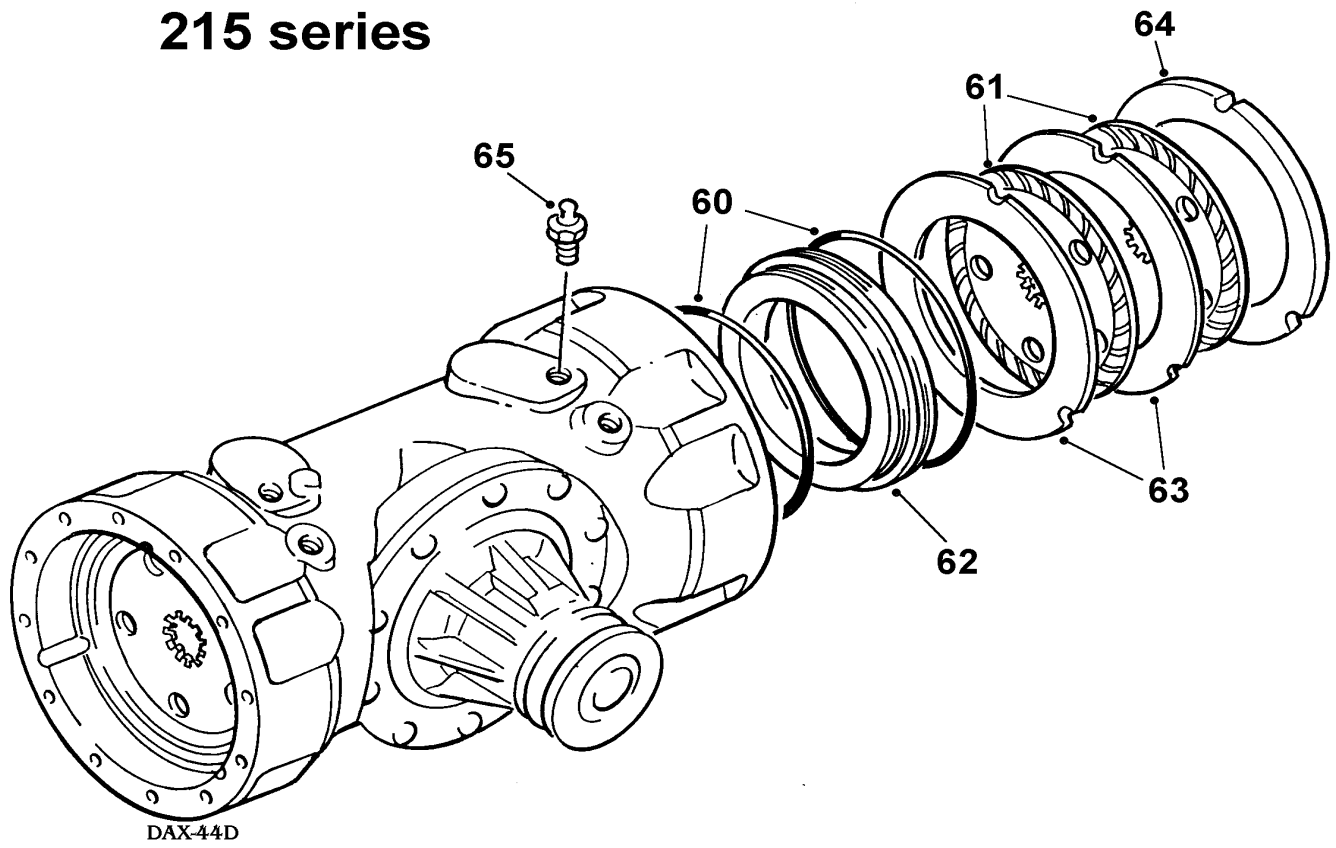



**BRAKES****B - 2D****Newage 215 series drive axle**

<b>Item</b>	<b>Part no</b>	<b>Serial no</b>	<b>Description</b>	<b>Qty</b>
60	30156A0108		KIT, 'O' ring seals, brake piston	1
*61	30156A0908		DISC, brake, sintered	4
62	30156A0107		PISTON, brake	2
*63	30156A0909		PLATE, brake, fixed	4
*64	30156A0910		SPACER, brake	2
65	30082A0419		VALVE, brake bleeding	1
	*30156A0911		Kit, brake plates, consisting of items marked *	

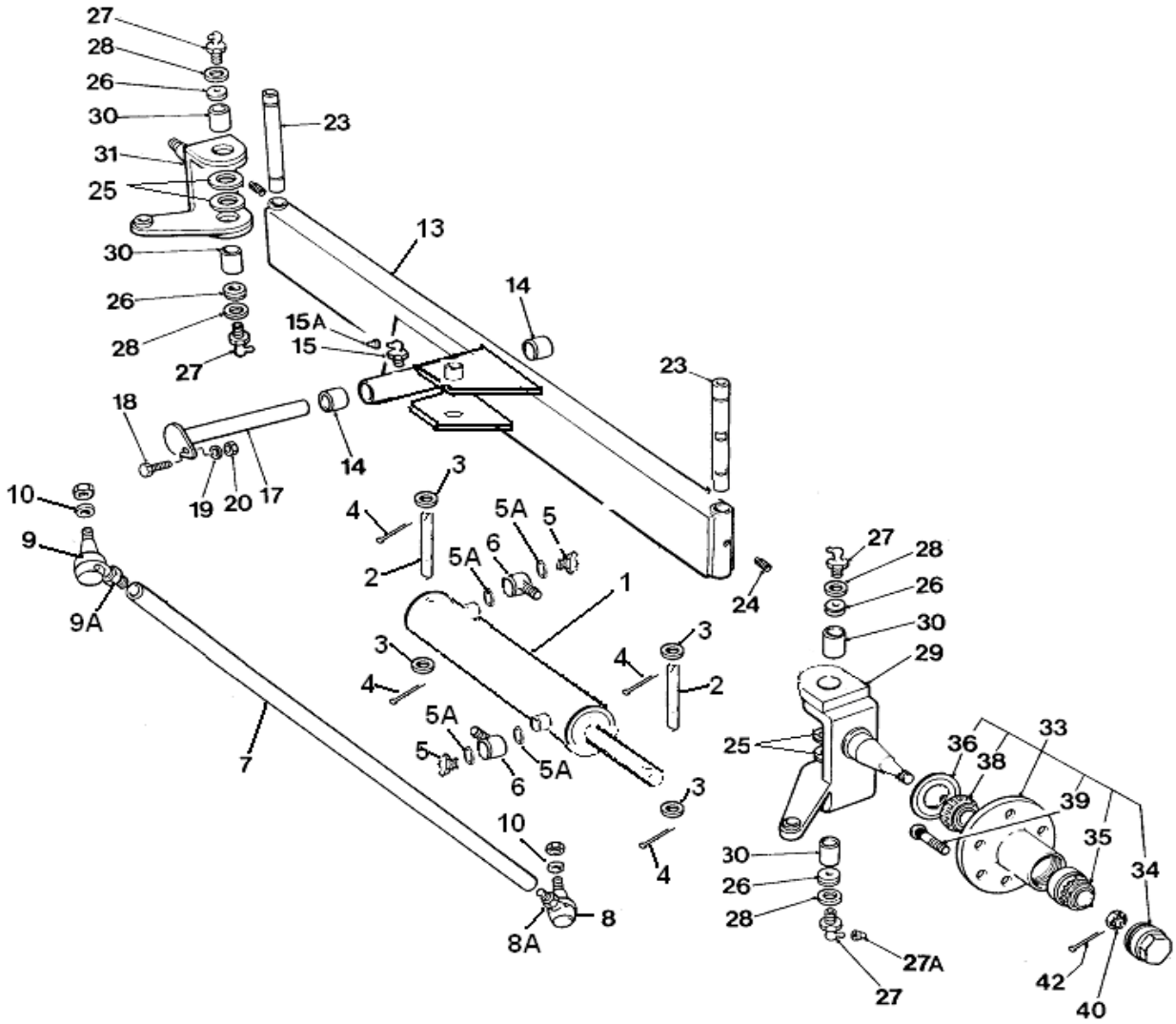

# STEERING AXLE & STEERING RAM

# B - 3

Item	Part no	Serial no	Description	Qty
1	V2005330		RAM, steering <i>see page H5</i>	1
2	V2005342		PIN, retaining	2
3	267S08		WASHER, flat	4
4	44S16J		PIN, split	4
5	115S03		BANJO,bolt	2
5A	100S02		SEAL, bonded	4
6	114S06D		BANJO, body, straight male	2
7	V2006336		TRACK ROD, 11/16" UNF threads	1
8	V2006335		BALL JOINT, RH, 11/16" UNF c/w nut	1
8A	95S13		NUT THIN, lock RH 11/16" UNF <i>order one 95S13 with each R.H. ball joint</i>	1
9	V2006334		BALL JOINT, LH, 11/16" UNF c/w nut	1
9A	272S17		NUT THIN, lock LH 11/16" UNF <i>order one 272S13 with each L.H. ball joint</i>	1
10	267S07		WASHER, flat, M12	2
13	30298A01		AXLE, steering	1
14	4SHL91		BUSH, axle pivot	2
15	131S02		NIPPLE, grease, 90 deg	1
15A	176S01		CAP, grease nipple	1
17	20161A05		PIN, axle pivot	1
18	8S04C		BOLT	1
19	267S06		WASHER	1
20	59S03		NUT, nylon insert	1
23	L264		KING PIN	2
24	185S05D4		SCREW, grub	2
25	C175		WASHER, thrust	4
26	C180A		WASHER, felt	4
27	131S02		NIPPLE, grease, 90 deg	4
27A	176S01		CAP, grease nipple	4
28	C180B		WASHER, flat, special	4
29	V2006325		STUB AXLE, R.H.	1
30	C190		BUSH, king pin	4
31	V2006324		STUB AXLE, L.H.	1
-	V602679		HUB, assembly	2
33	-		HUB ( <i>order V602679 assembly</i> )	1
34	V602676		HUB CAP	1

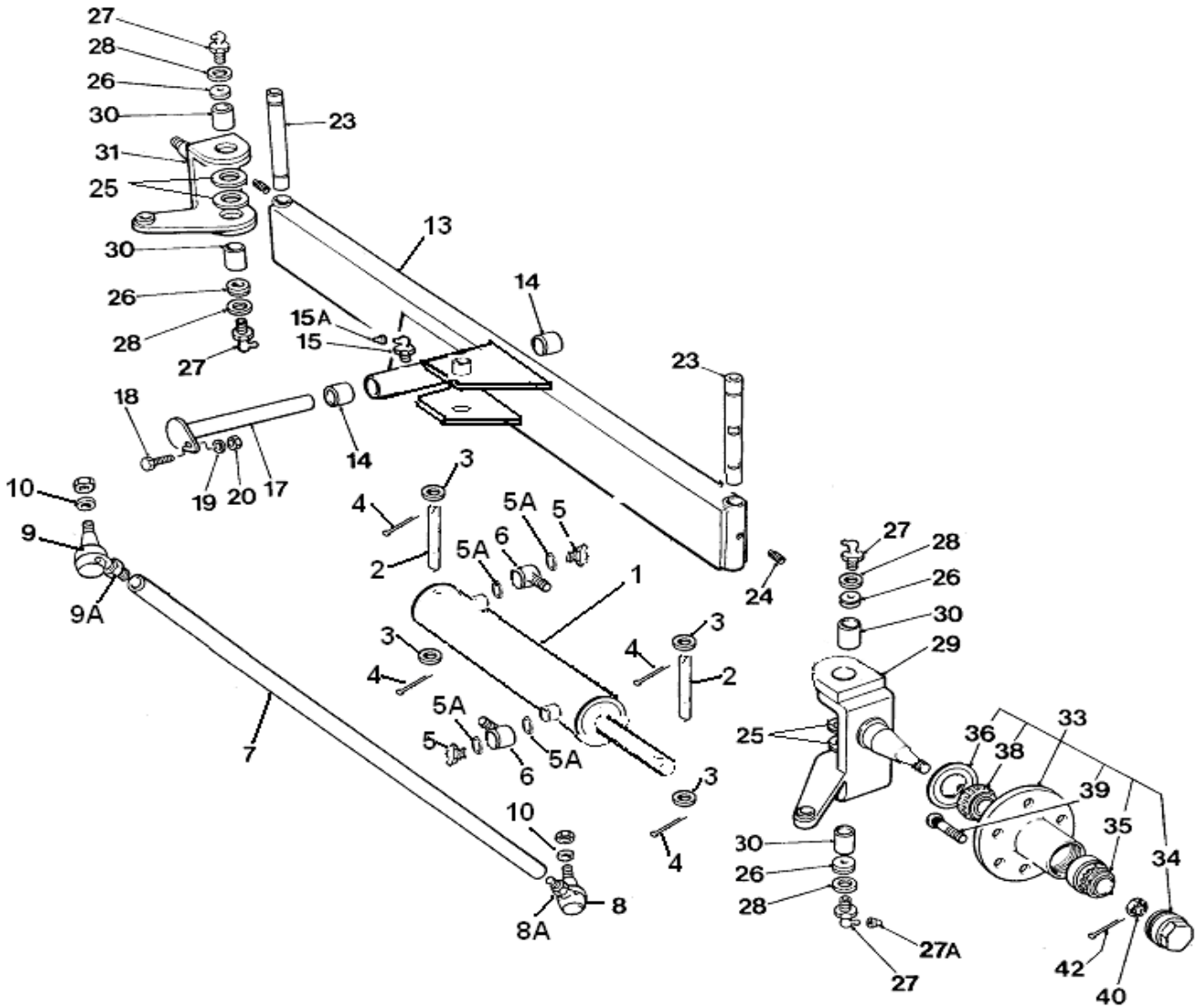

# STEERING AXLE & STEERING RAM

**B - 3**

Item	Part no	Serial no	Description	Qty
35	V602666		BEARING, hub, outer	1
36	V602668		SEAL, oil, hub bearing	1
38	V602667		BEARING, hub, inner	1
39	V602677		STUD, wheel	3
40	V603755		NUT, slotted, 40mm across flats	1
42	44S04E		PIN, split	1



# 2B1500 DUMPER

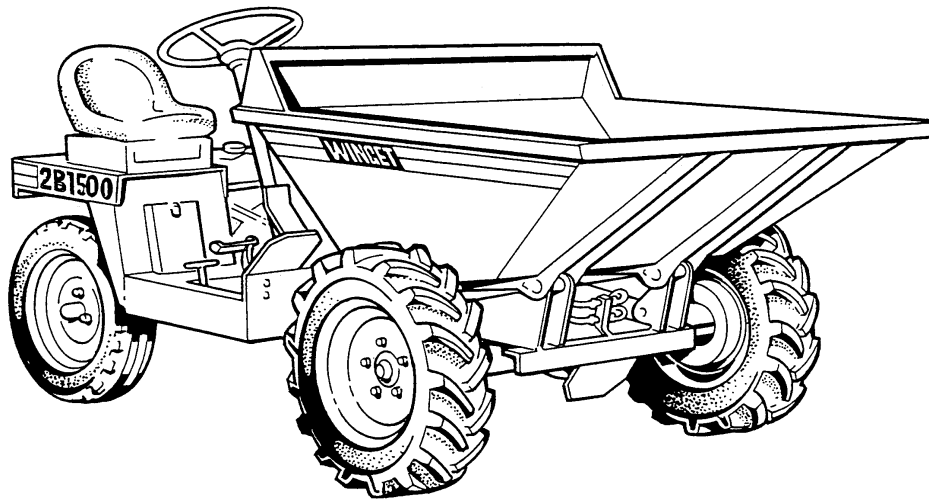





# ***Transmission***

**GEARBOX, Newage**  
**Used with Newage 215 axle** **C - 1**

---

**FLYWHEEL & CLUTCH** **C - 2**

---

**CLUTCH PEDAL** **C - 3**

---

**PROPELLER SHAFT** **C - 4**

---

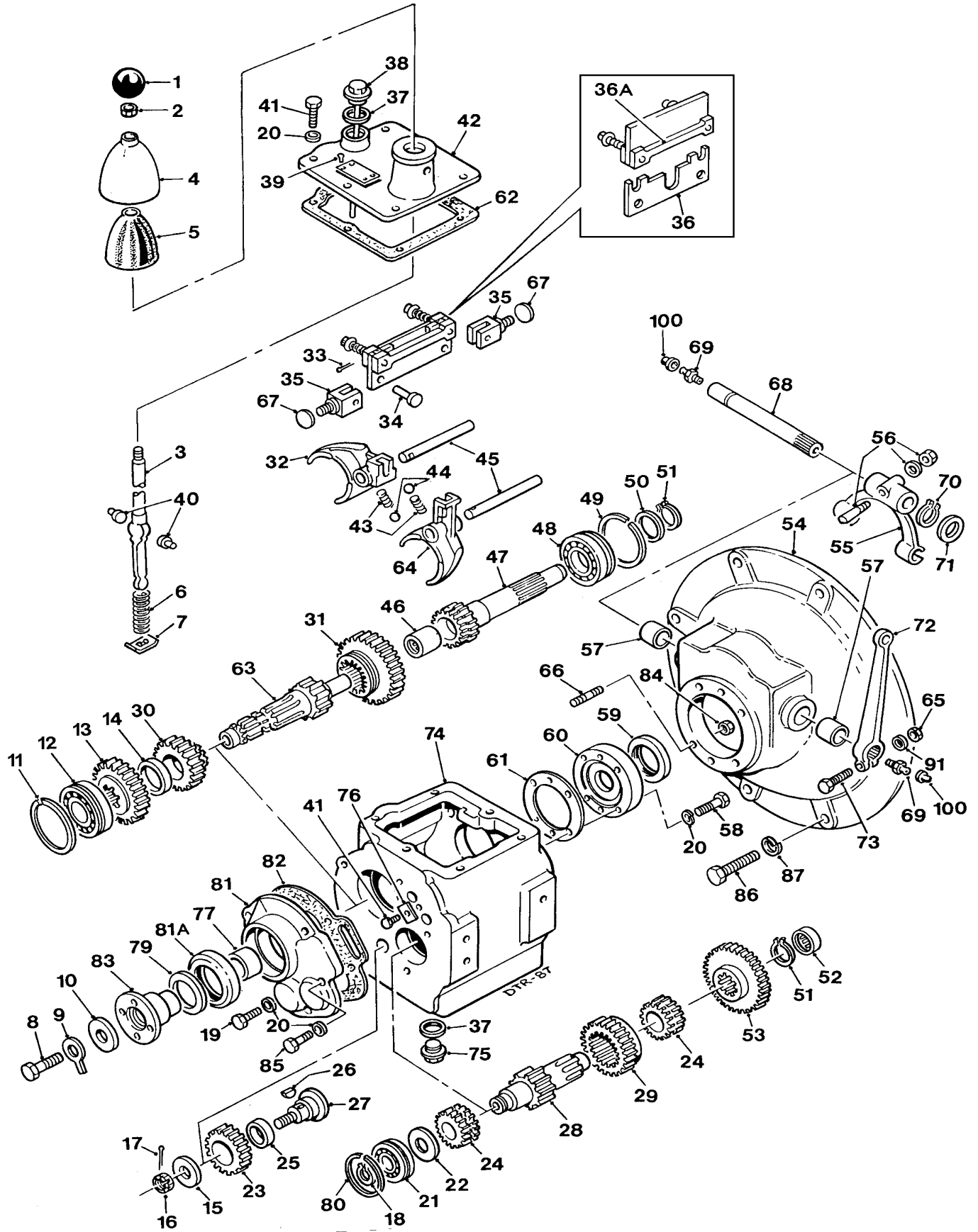

**GEARBOX (Used with Newage 215 axles)****C - 1**

Item	Part no	Serial no	Description	Qty
-	30101A04		GEARBOX, (40M2S322), assembly,	1
1	30101A0201		KNOB, gear lever	1
2	95S03		NUT, locking	1
3	20097A05		LEVER, gear	1
4	30101A0203		CAP, gear lever	1
5	30101A0204		GAITER, gear lever	1
6	30101A0205		SPRING, gear lever	1
7	30101A0206		PLATE, gear lever retaining	1
8	28S05E		BOLT	1
9	30101A0207		WASHER, tab	1
10	30101A0208		WASHER	1
11	30101A0209		RING, snap	1
12	88S06E		BEARING, mainshaft, rear	1
13	30101A0211		GEAR, output	1
14	30101A0212		SPACER, output gear	1
15	30101A0213		WASHER, reverse pinion shaft	1
16	102S04		NUT, slotted	1
17	44S02C		PIN, split	1
18	30218A0206		CIRCLIP	1
19	28S01D		BOLT	3
20	30039A0169		WASHER, nylon	9
21	88S04E		BEARING, layshaft	1
22	30101A0217		SPACER, bearing	1
23	30101A0218		PINION, reverse	2
24	30101A0219		GEAR, reverse	2
25	30101A0220		BUSH, reverse pinion	1
26	30101A0221		KEY	1
27	30101A0222		SHAFT, reverse pinion	1
28	30101A0280	0155335 /	# LAYSHAFT (Metric)	1
29	30101A0224		GEAR, 2nd speed, sliding	1
30	30101A0225		GEAR, 2nd speed	1
31	30101A0226		GEAR, 1st speed	1
32	30101A0227		FORK, 2nd & 3rd selector	1
33	44S01C		PIN, split	2
34	30101A0228		PIN, clevis	2
35	30101A0229		CLEVIS, interlock plate	2
36	30101A0276		PLATE, interlock	1
36A	30101A0275		SPRUNG INTERLOCK, c/w installation tool	1
37	42S05		WASHER, sealing	2
38	30218A0248		DIPSTICK, (flange to bottom =6")	1
39	—		SCREW, drive (for serial no. plate)	4

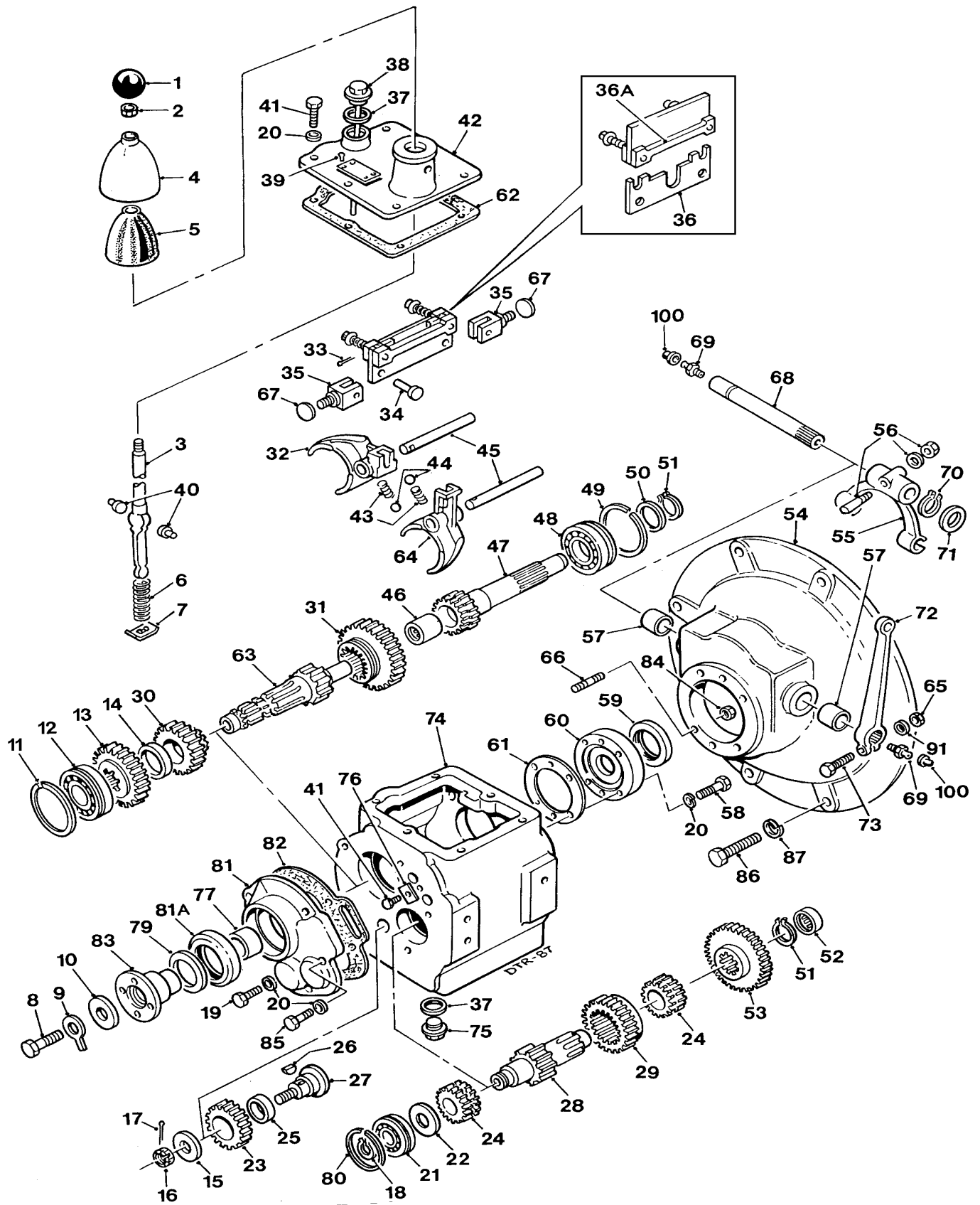

**GEARBOX (Used with Newage 215 axles)****C - 1**

Item	Part no	Serial no	Description	Qty
40	30101A0234		PAD, gear lever	2
41	28S01C		BOLT	7
42	30101A0235		COVER, top	1
43	30097A0185		SPRING, detent	2
44	30097A0199		BALL, detent	2
45	30101A0237		SHAFT, selector	2
46	30101A0238		BEARING, needle (part of item 47)	1
47	30101A0239		SHAFT, primary, assy (with item46)	1
48	88S16F		BEARING, input	1
49	30101A0241		RING, snap	1
50	30101A0242		SPACER, bearing	1
51	30101A0243		CIRCLIP	2
52	30101A0279	0155335 /	BEARING (Metric), layshaft	1
53	30101A0245		GEAR, 1st reduction	1
54	30101A0246		HOUSING, clutch	1
55	30097A0110		FORK, clutch release	1
56	30097A0111		COTTER, NUT & WASHER	1
57	30097A0114		BUSH, cross shaft	2
58	6S01A		BOLT	4
59	30101A0247		SEAL, (part of item 60)	1
60	30101A0248		COVER, front assy. (with item 59)	1
61	30101A0249		GASKET, front cover	1
62	30101A0250		GASKET, top cover	1
63	30101A0251		OUTPUT SHAFT	1
64	30101A0252		FORK, selector, 1st & reverse	1
65	9S01		NUT	1
66	30101A0253		STUD	6
67	30101A0254		PLUG	3
68	30101A0255		SHAFT, clutch cross	1
69	131S06		NIPPLE, grease	2
70	30101A0256		CIRCLIP	1
71	30097A0133		WASHER, cross shaft	1
72	30097A0109		LEVER, clutch release	1
73	6S01C		BOLT	1
74	30101A0281	0155335 /	CASE, gearbox	1
75	30097A0163		PLUG, drain	1
76	30101A0259		STRIP, selector locking	1
77	30101A0260		SPACER	1
79	30101A0265		SHIELD, dust	1
80	30101A0261		RING, snap	1
81	30101A0262		COVER, output, assembly	1
81A	89S02		SEAL, oil	1
82	30101A0263		GASKET, output cover	1

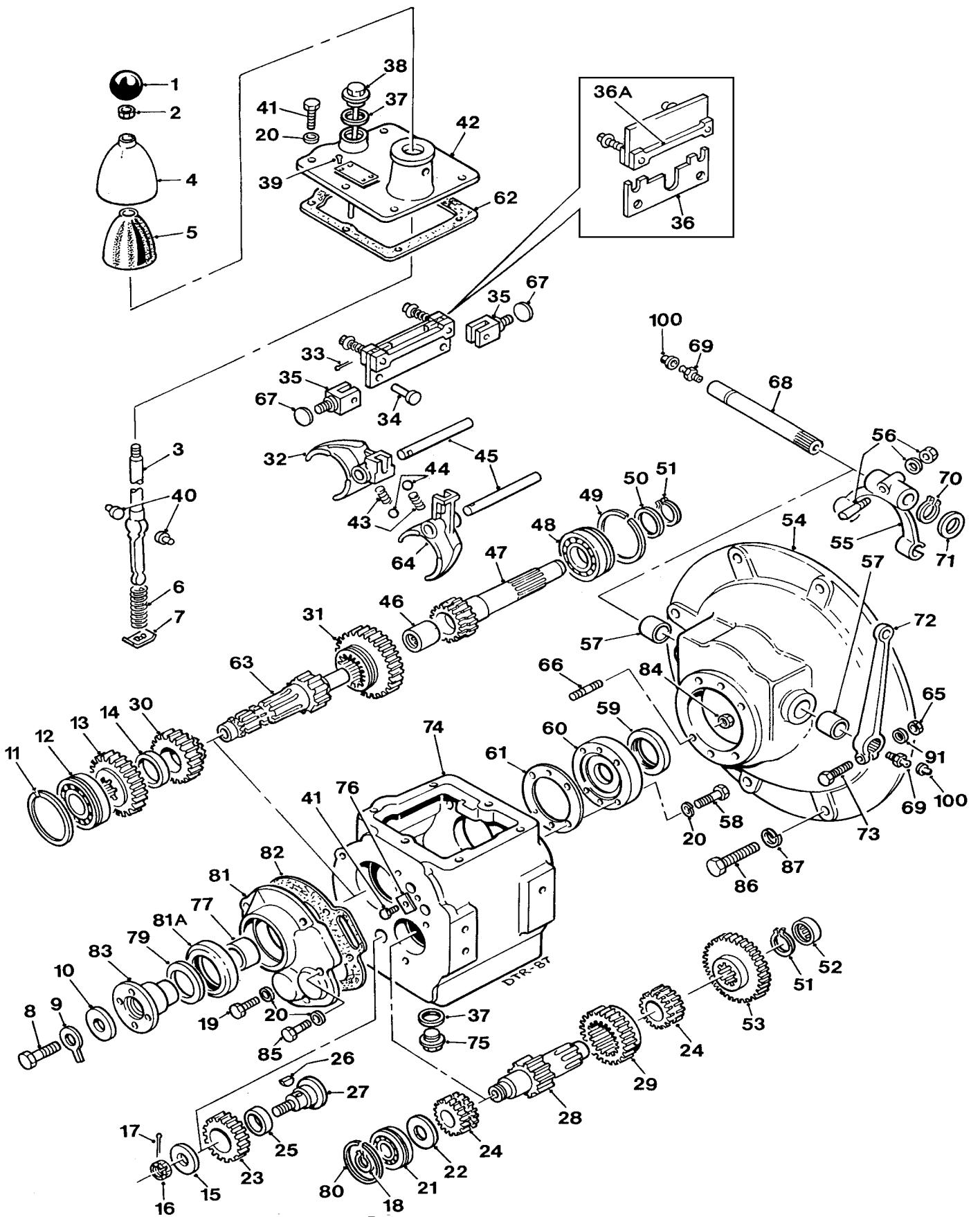

**GEARBOX (Used with Newage 215 axles)****C - 1**

<b>Item</b>	<b>Part no</b>	<b>Serial no</b>	<b>Description</b>	<b>Qty</b>
83	30218A0203		COUPLING	1
84	107S03		NUT	6
85	6S01B		BOLT	2
86	66S03A		SCREW, set, Imperial, UNC	8
86	11S04C		SCREW, set, Metric	8
87	41S05		WASHER, spring, Imperial	8
87	17S05		WASHER, spring, Metric	8
<b><i>Confirm threads in Engine Adaptor Ring to identify correct set screws</i></b>				
91	67S01		WASHER, shake proof	1
100	176S01		CAP, grease nipple	2

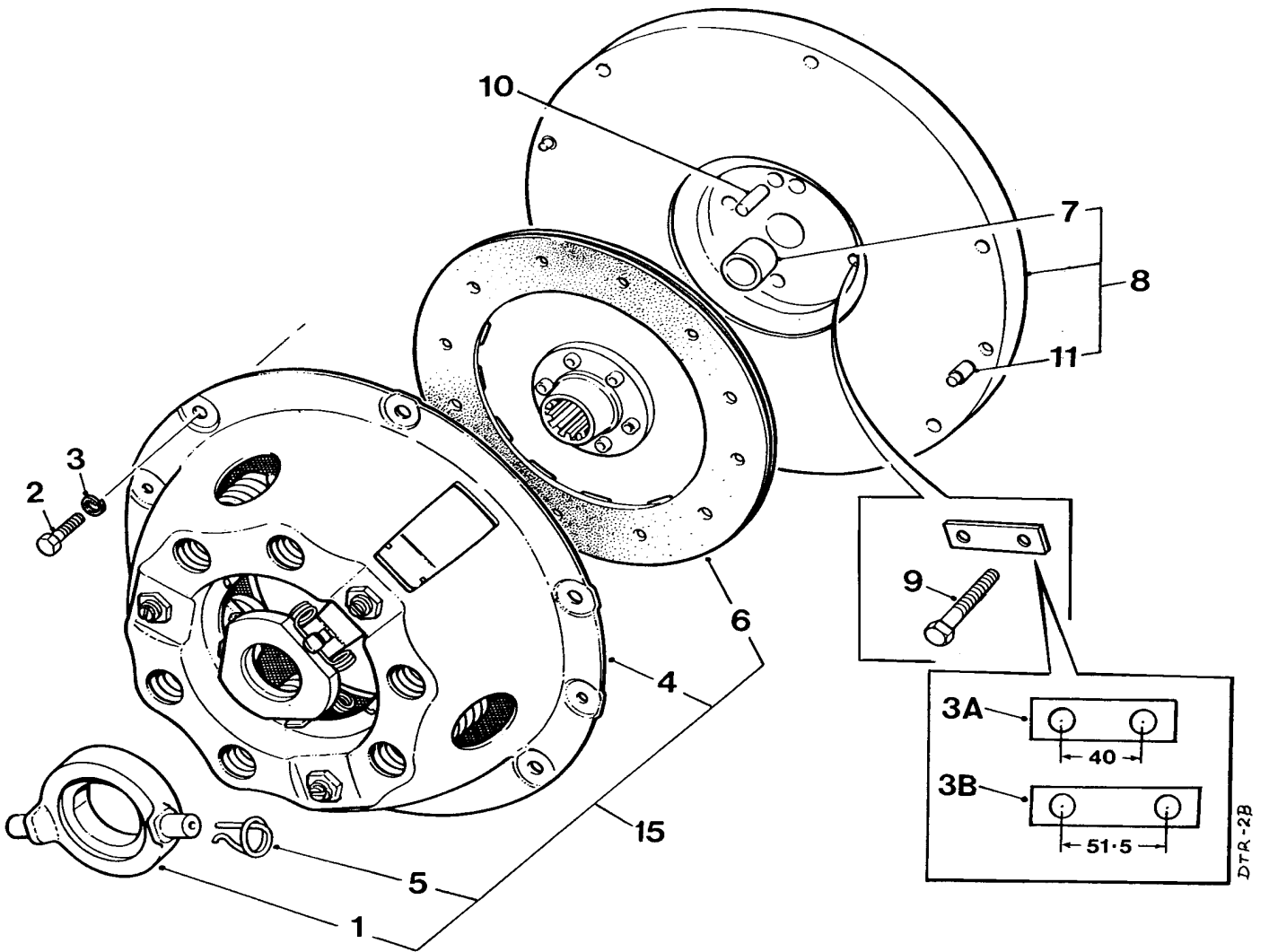

DTR-2B



**FLYWHEEL & CLUTCH****C - 2**

<b>Item</b>	<b>Part no</b>	<b>Serial no</b>	<b>Description</b>	<b>Qty</b>
1	10579A01		BEARING, release	1
2	28S02D		SCREW	6
3	41S04		WASHER, spring	6
3A	10531A02		WASHER, locking, 60mm long, Lister-Petter TR1 engines	1
3B	10531A03		WASHER, locking, 70mm long, Lister-Petter TR1 engines	1
4	10597A01		COVER	1
5	10579A0101		SPRING, retaining, release bearing	2
6	10598A02		PLATE, drive, 8"	1
7	10580A0101		BUSH	1
8	10580A02		FLYWHEEL, 8"	1
9	8S03B		BOLT, Lister-Petter TR1 engines	4
10	C321		DOWEL	1
11	10580A0102		DOWEL	2
15	10948A02		KIT, Clutch repair <i>Consists of items 1,4,5 &amp; 6</i>	1

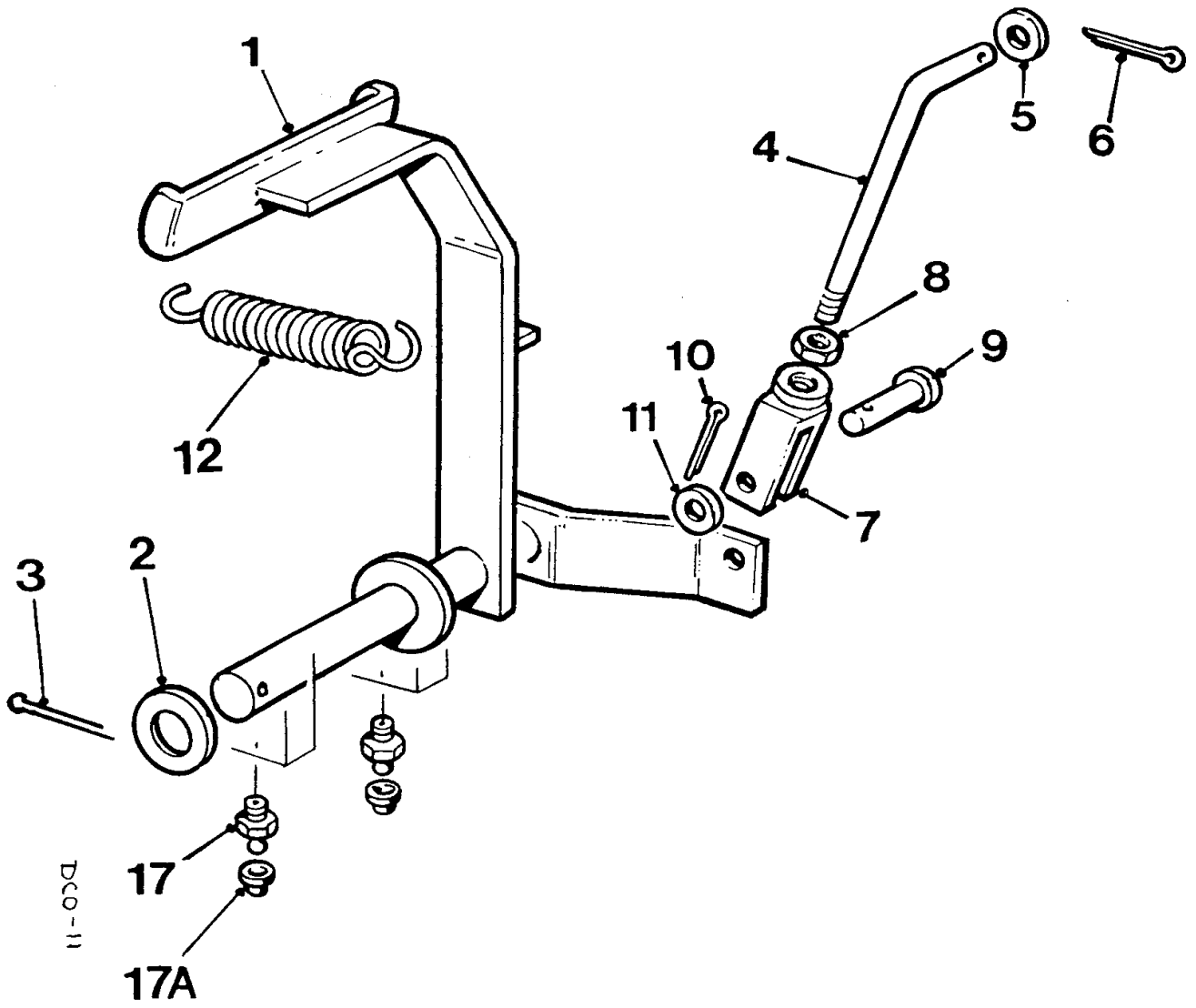

**CLUTCH PEDAL****C - 3**

<b>Item</b>	<b>Part no</b>	<b>Serial no</b>	<b>Description</b>	<b>Qty</b>
1	20096A07		PEDAL, clutch	1
2	10S08		WASHER, flat	1
3	44S05E		PIN, split	1
4	10481A03		ROD, clutch	1
5	10S03		WASHER, flat	1
6	44S03C		PIN, split	1
7	C174J		CLEVIS	1
8	95S03		NUT	1
9	10650A18		PIN, clevis	1
10	44S02C		PIN, split	1
11	10S03		WASHER, flat	1
12	C173B		SPRING, return	1
17	131S01		NIPPLE, grease	2
17A	176S01		CAP, grease nipple	2

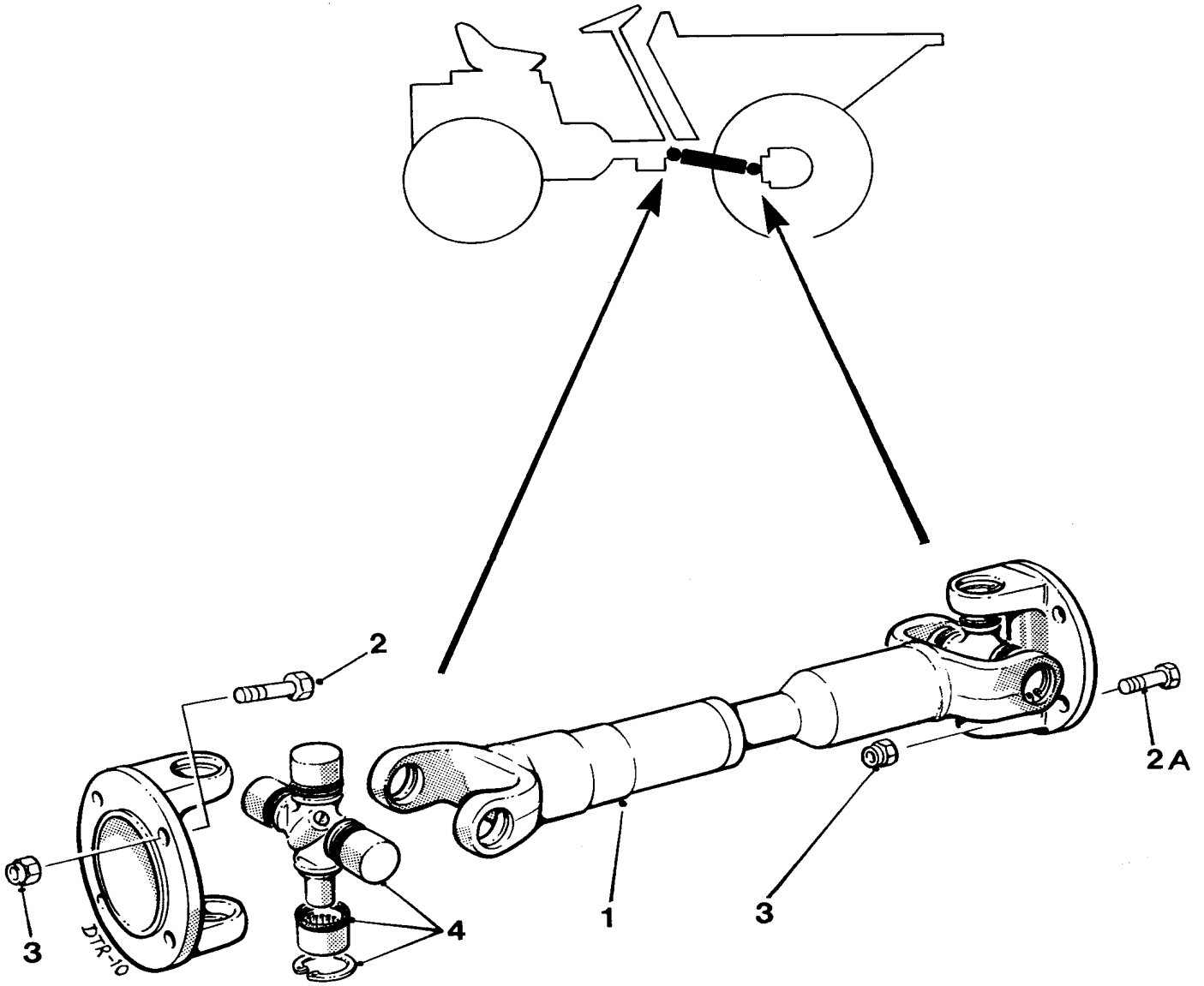

# PROPELLER SHAFT

C - 4

Item	Part no	Serial no	Description	Qty
1	20088A01		PROPELLER SHAFT	1
.....	176S01		CAP, grease nipple ( <i>not illustrated</i> )	3
2	6S03C		BOLT, gearbox end, 1 1/2" long	4
2A	6S03A		BOLT, axle end, 1 1/8" long	4
3	107S14		NUT, 3/8" nylon insert, full	8
4	10568A01		KIT, U/J, repair	AR
.....	131S06		NIPPLE, grease ( <i>not illustrated</i> )	3



# 2B1500 DUMPER

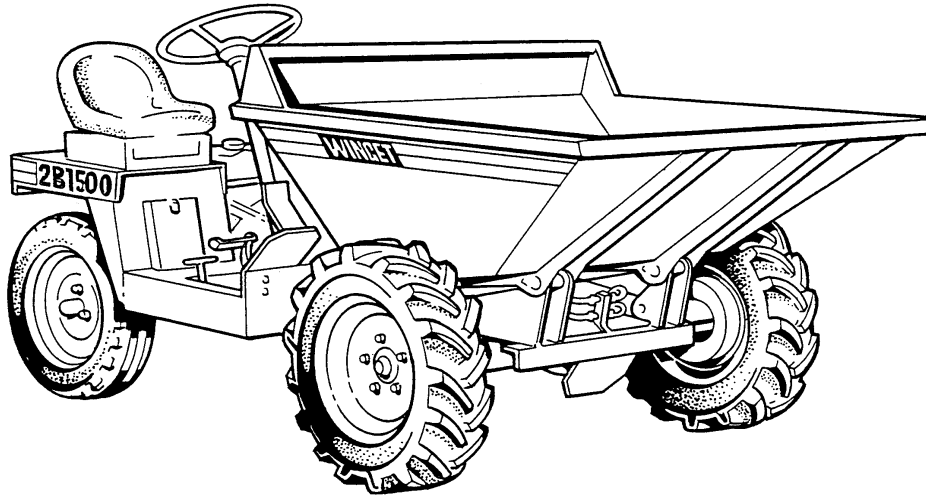





# ***Brakes***

**HANDBRAKE, CABLE & CALIPER**

---

**D - 1**

**CALIPER**

---

**D - 2**

**BRAKE PEDAL**

---

**D - 3**

**BRAKE HOSES & FITTINGS**

---

**D - 4**

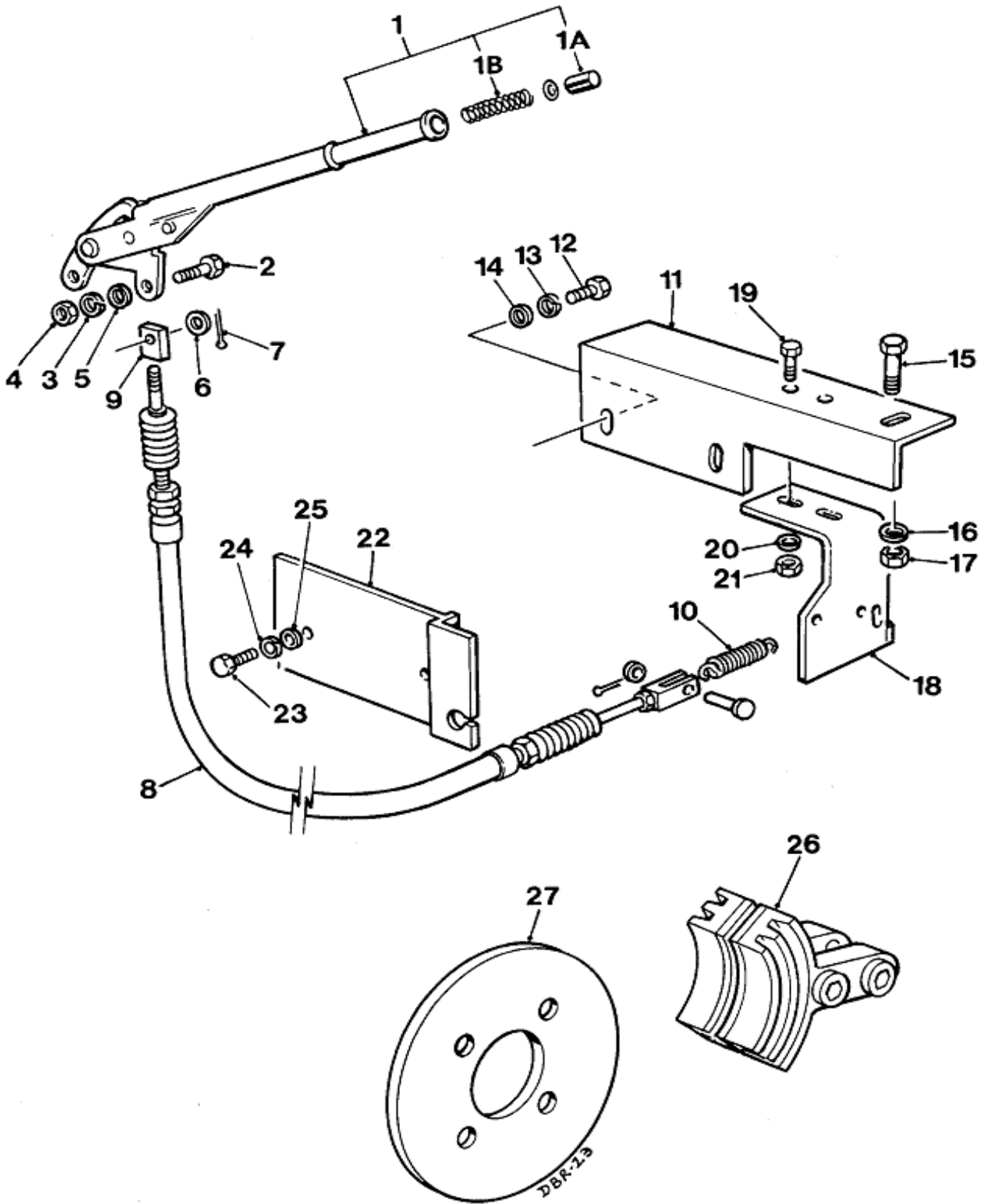

**HANDBRAKE, (Newage axles only)****D - 1**

<b>Item</b>	<b>Part no</b>	<b>Serial no</b>	<b>Description</b>	<b>Qty</b>
1	20208A01		LEVER, handbrake assembly	1
1A	20208A0101		BUTTON, handbrake	1
1B	20208A0102		SPRING, handbrake	1
2	11S04C		SCREW	2
3	17S05		WASHER, spring	2
4	7S04		NUT	2
5	267S06		WASHER, flat	2
6	10S03		WASHER, flat	1
7	44S02B		PIN, split	1
8	20273A02		CABLE, handbrake	1
9	L309		BLOCK	1
10	C173D		SPRING, return	1
11	20282A11		BRACKET, gearbox mounting	1
12	28S03D		SCREW, set	2
13	41S05		WASHER, spring	4
14	10S03		WASHER, flat	2
15	8S05D		BOLT	1
16	267S07		WASHER, flat	1
17	59S04		NUT, nylon insert	1
18	20282A07		BRACKET, caliper mounting	1
19	11S03C		SCREW, set	2
20	267S05		WASHER, flat	2
21	59S12		NUT, nylon insert	2
22	20282A08		BRACKET	1
23	28S03D		SCREW, set	2
24	41S05		WASHER, spring	2
25	10S03		WASHER, flat	2
26	10578A01		CALIPER, disc brake	1
27	10385A02		DISC, handbrake	1

1A

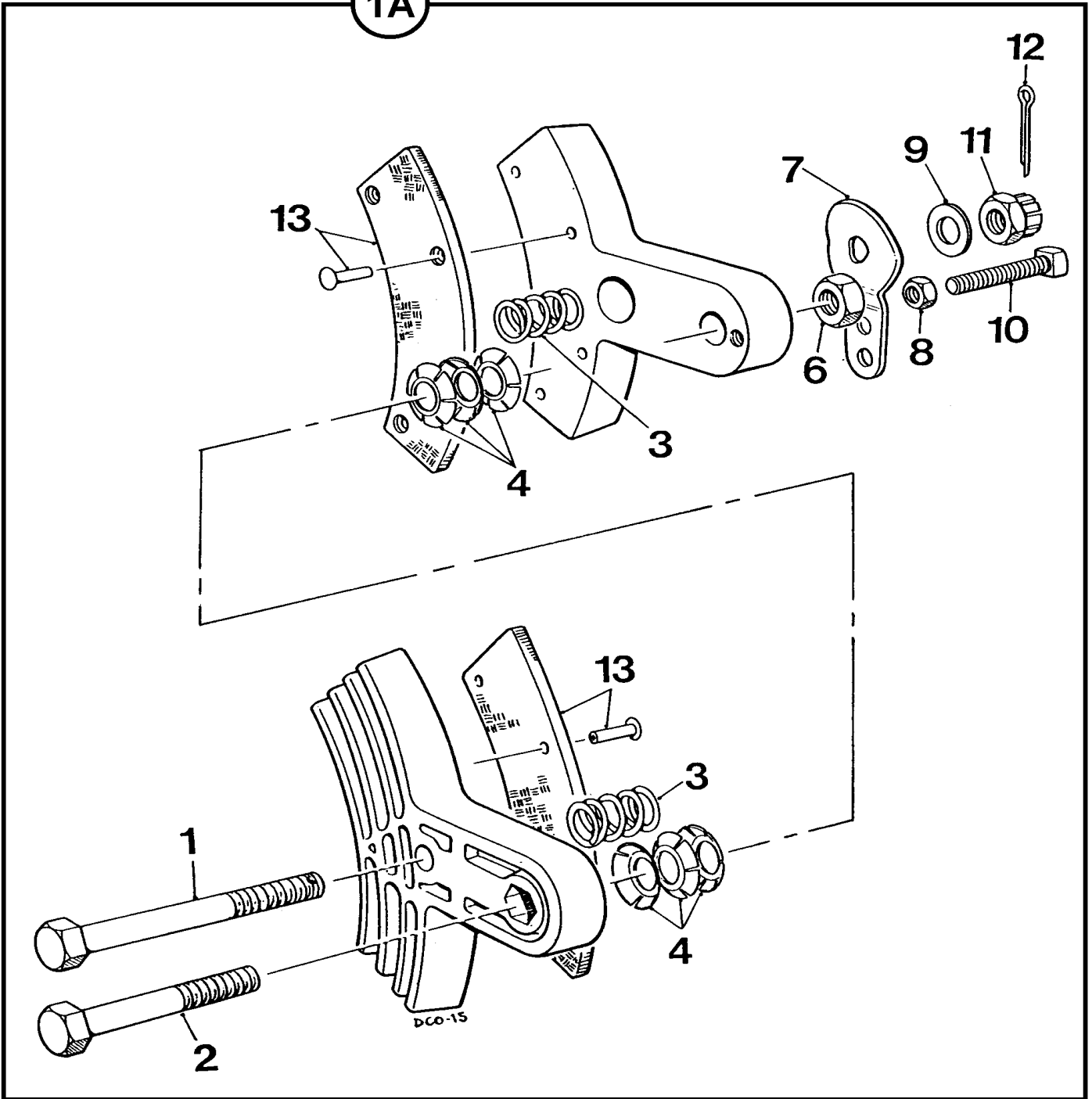

Item	Part no	Serial no	Description	Qty
<b>ALLOY CALIPERS</b>				
1A	10578A01		CALIPER, one pair, assembly	1
1	11116		SCREW, with hole for pin, item 12	1
2	28S02P		SCREW	1
3	10578A0101		SPRING, centring	4
4			TENSION WASHER (obsolete) <i>use item 3 above</i>	
6	9S02		NUT	1
7	10578A0104		CAM	1
8	230S01		NUT, locking	1
9	10578A0105		WASHER	1
10	66S01H		SCREW, set	1
11	227S02		NUT, castle	1
12	44S01C		PIN, cotter	1
13	1072A4		PAD c/w rivets	2
<b>STEEL CALIPERS</b>				
1A	10578A01		CALIPER, one pair, assembly	1
1	8S03M		BOLT	1
2	8S03J		BOLT	1
3	10578A0101		SPRING, centring	4
6	59S12		NUT, nyloc	1
7	10578A0104		CAM	1
8	7S02		NUT	1
9	10578A0105		WASHER	1
10	11S02H		SCREW, set	1
11	59S12		NUT, nyloc	1
13	1072A4		PAD c/w rivets	2

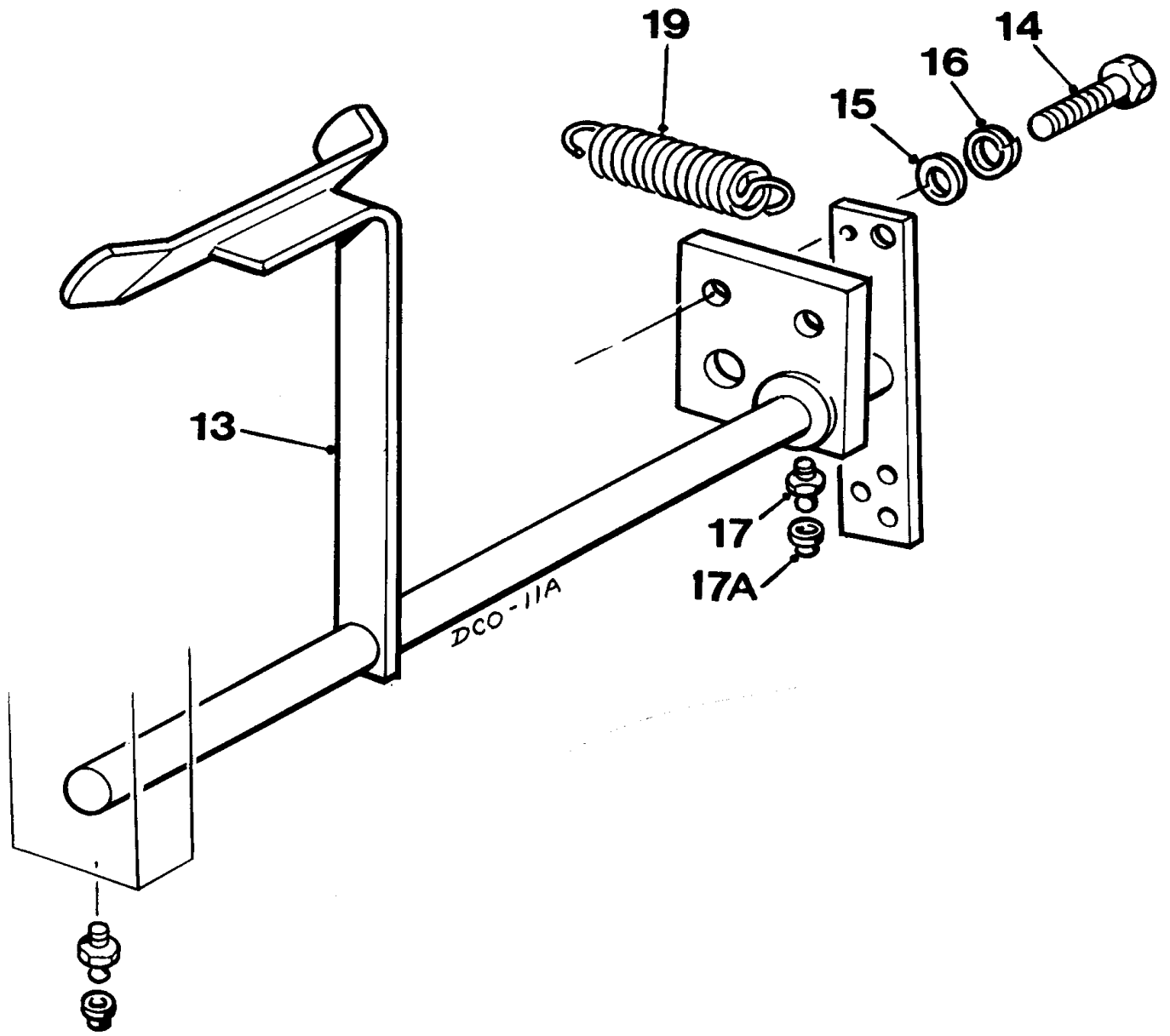

**BRAKE PEDAL****D - 3**

<b>Item</b>	<b>Part no</b>	<b>Serial no</b>	<b>Description</b>	<b>Qty</b>
13	20232A02		PEDAL, brake	1
14	8S04C		BOLT	2
15	267S06		WASHER, flat	2
16	17S05		WASHER, spring	2
17	131S01		NIPPLE, grease, threaded	2
17A	176S01		CAP, grease nipple	2
19	C173B		SPRING	1

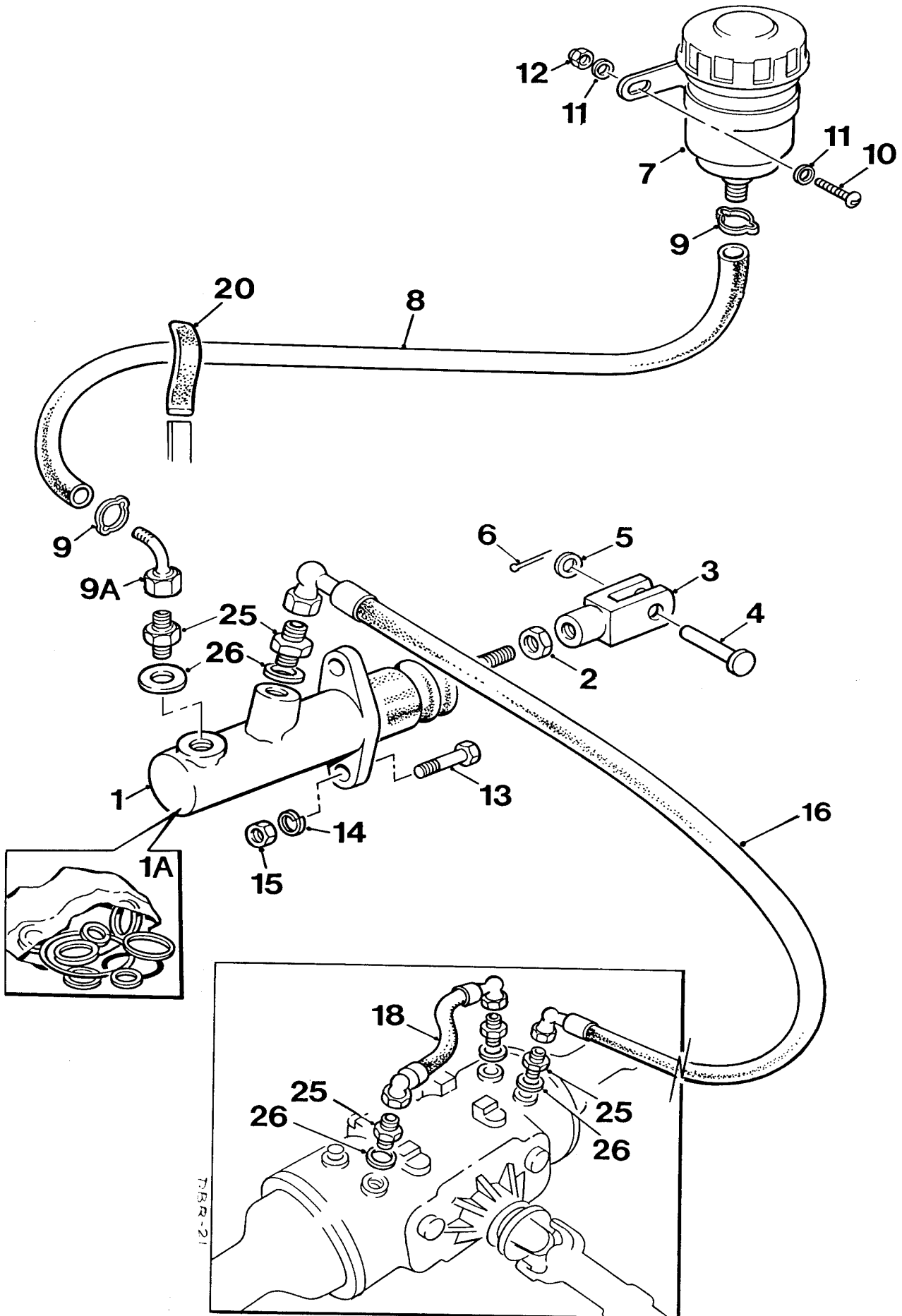



**BRAKE HOSES & FITTINGS****D - 4**

Item	Part no	Serial no	Description	Qty
1	20102A02		MASTER CYL. M10 rod, Girling	1
1A	10570A01		REPAIR KIT, m/cyl. Girling	1
2	7S04		NUT, 10mm	1
3	V2004648		CLEVIS, 10mm	1
4	10650A18		PIN, clevis	1
5	10S03		WASHER, flat	1
6	44S02C		PIN, split	1
7	V2003030		RESERVOIR c/w clip	1
8	V2002991		HOSE, (res.to m/cyl.) <i>order by meter</i>	
9	V2003029		CLIP, hose	2
9A	129S01A		ADAPTOR, elbow 90 deg.	1
10	82S03E		SCREW, set	2
11	10S73		WASHER, flat	4
12	85S01		NUT, "Nyloc"	2
13	8S03C		BOLT	2
14	17S04		WASHER, spring	2
15	7S03		NUT	2
16	53S01P		HOSE, brake (master cylinder to axle)	1
18	53S01W		HOSE, brake, (axle bridge)	1
20	208143000		SLEEVE, P.V.C., black	2
25	V2003515		ADAPTOR, male/male	5
26	298S03		SEAL, bonded	5



# 2B1500 DUMPER

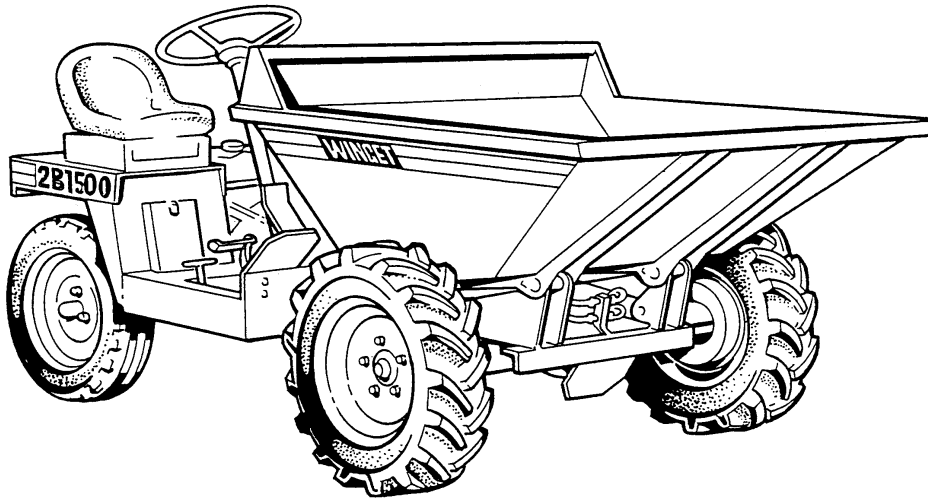



# ***Engine & Controls***

**LISTER-PETTER TR1 ENGINE**

---

**E - 1**

**ACCELERATOR PEDAL & LINKAGE**

---

**E - 2**

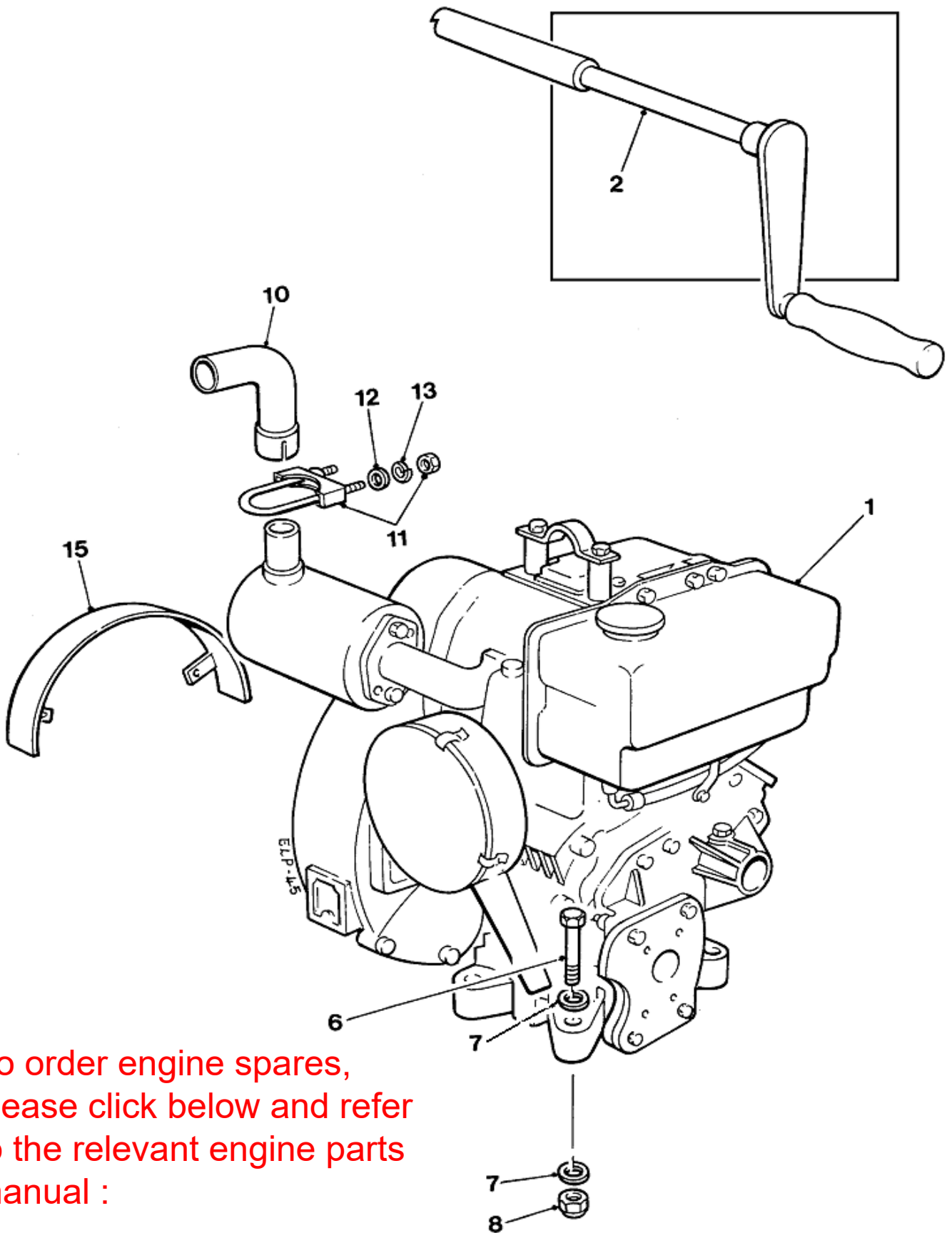

To order engine spares,  
please click below and refer  
to the relevant engine parts  
manual :

[LISTER PETTER TR1](#)

**ENGINE, LISTER PETTER TR1****E - 1**

<b>Item</b>	<b>Part no</b>	<b>Serial no</b>	<b>Description</b>	<b>Qty</b>
1	V2000759		Engine, TR1, hand start <i>(hydraulic pump drive)</i>	1
1	V2000760		Engine, TR1, electric start <i>(hydraulic pump drive)</i>	1
2	20354A03		HANDLE, starting	1
6	8S05J		BOLT	4
7	267S07		WASHER, flat	8
8	59S04		NUT, nylon insert	4
10	---		# PIPE, exhaust # <i>Supplied with engine</i>	
11	153S08		CLAMP	1
12	267S05		WASHER, flat	2
13	17S04		WASHER, spring	2
15	10987A02		HOUSING, clutch	1

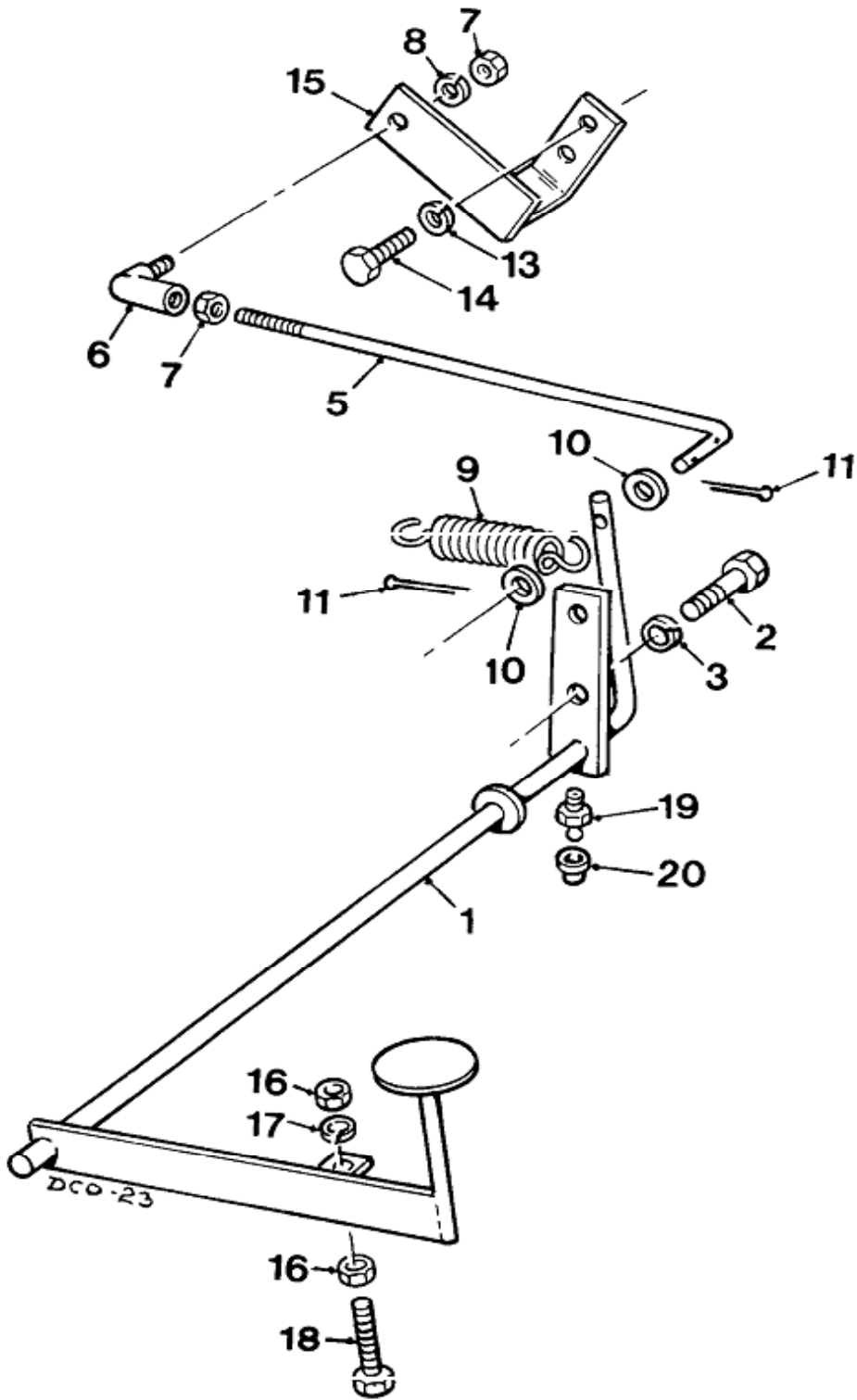



**ACCELERATOR PEDAL & LINKAGE****E - 2**

<b>Item</b>	<b>Part no</b>	<b>Serial no</b>	<b>Description</b>	<b>Qty</b>
1	20231A03		PEDAL, accelerator	1
2	8S04C		BOLT	2
3	17S05		WASHER	2
5	10362A17		ROD	1
6	C160B		BALL END	1
7	2S02		NUT	2
8	41S03		WASHER, spring	1
9	C173D		SPRING, return	1
10	267S04		WASHER, flat	2
11	44S02C		PIN, split	2
13	17S03		WASHER, spring	1
14	11S02A		SCREW, set	1
15	11031A03		LEVER,	1
16	7S03		NUT,	2
17	17S04		WASHER, spring	1
18	11S03J		SCREW, set	1
19	131S01		NIPPLE, grease	1
20	176S01		CAP, grease nipple	1



# 2B1500 DUMPER

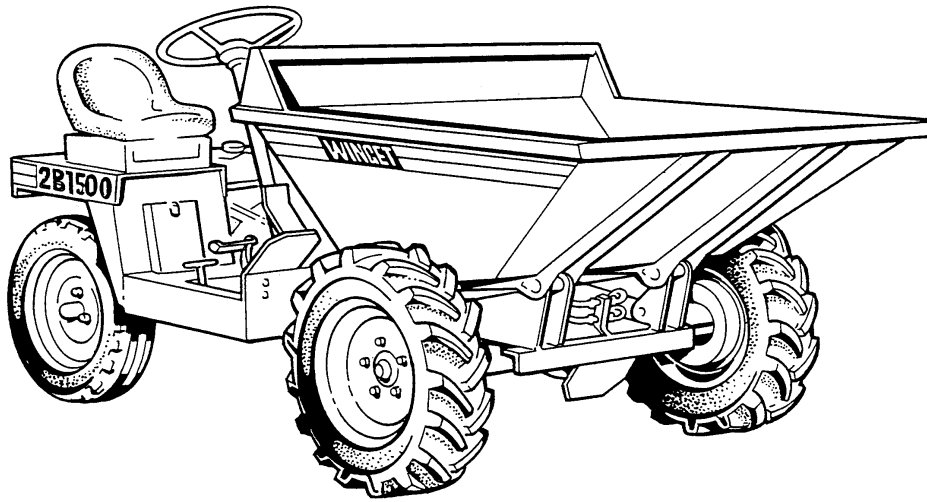



# ***Electrics***

## **CHARGING & STARTING CIRCUIT**

**Lister Petter TR1 electric start engine**

---

**F - 1**

## **MAIN ELECTRICAL CIRCUIT.**

---

**F - 2**

## **ROAD LIGHTS.**

---

**F - 3**

## **CONSOLE, road lights.**

---

**F - 4**

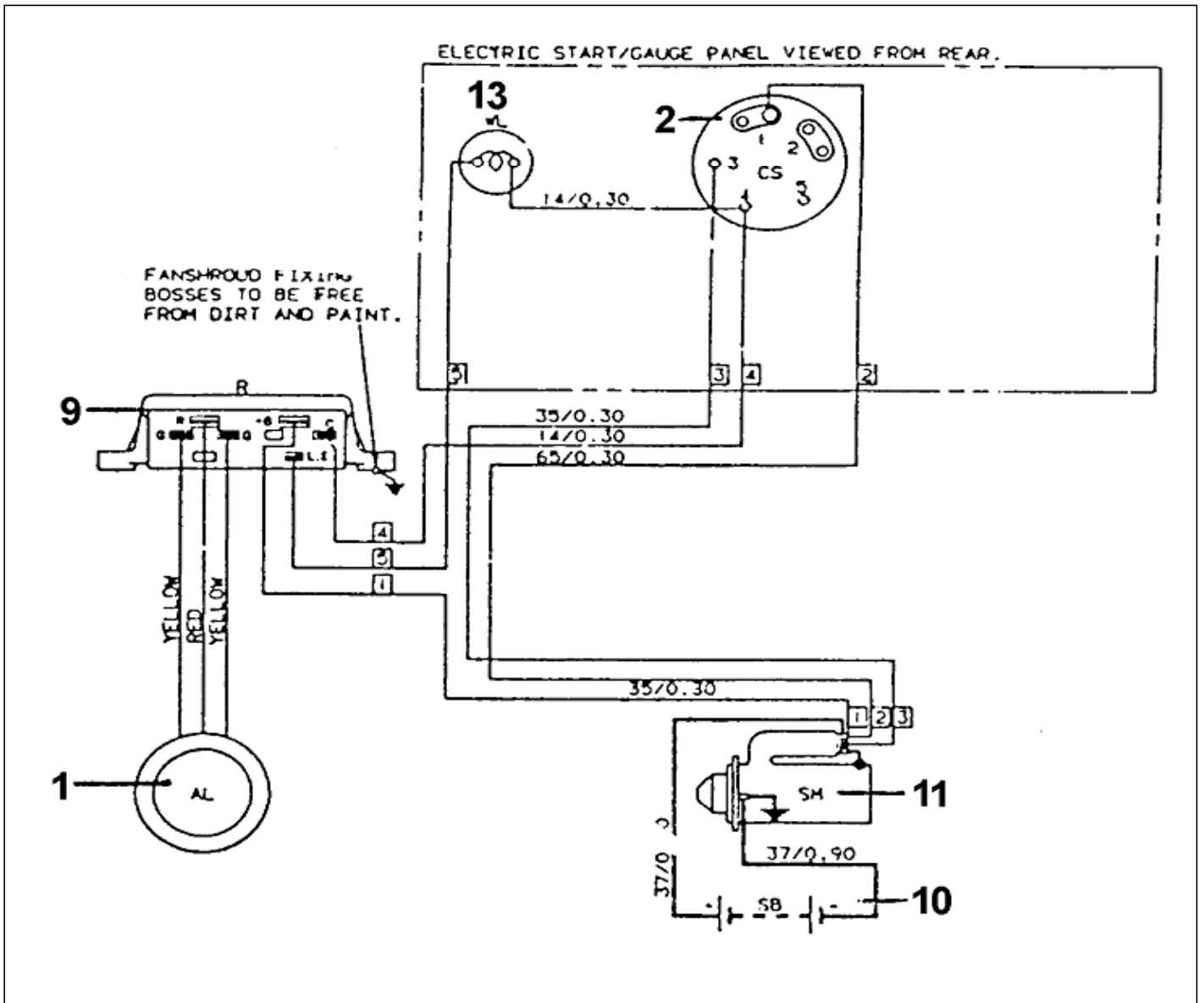

**CHARGING & STARTING CIRCUIT**  
**Lister Petter TR1 electric start engine**

**F - 1**

Item	Part no	Serial no	Description	Qty
<b>Lister Petter TR1 Engines fitted with 'Nicsa' charging system</b>				
1	EL36608142		+ STATOR, flywheel alternator	1
1A	EL36608143		+ ROTOR, flywheel alternator	1
2	V2004189		SWITCH, key start	1
9	EL36608144		+ REGULATOR	1
10	109S08		BATTERY	1
11	EL57030421		+ STARTER MOTOR	1
13	V602634		LIGHT, warning	1
			+ <i>Items supplied with engine.</i>	
			<i>For engine parts, see "Engine Parts Cat."</i>	
-	30231A11		LOOM <i>see page F-2</i>	1
-	20313A06		PANEL <i>see page F-2</i>	1
-	11S02C		SCREW, set, panel fixing ( <i>not illustrated</i> )	2
-	17S03		WASHER, spring ( <i>not illustrated</i> )	2
-	246S04		WASHER, flat ( <i>not illustrated</i> )	2

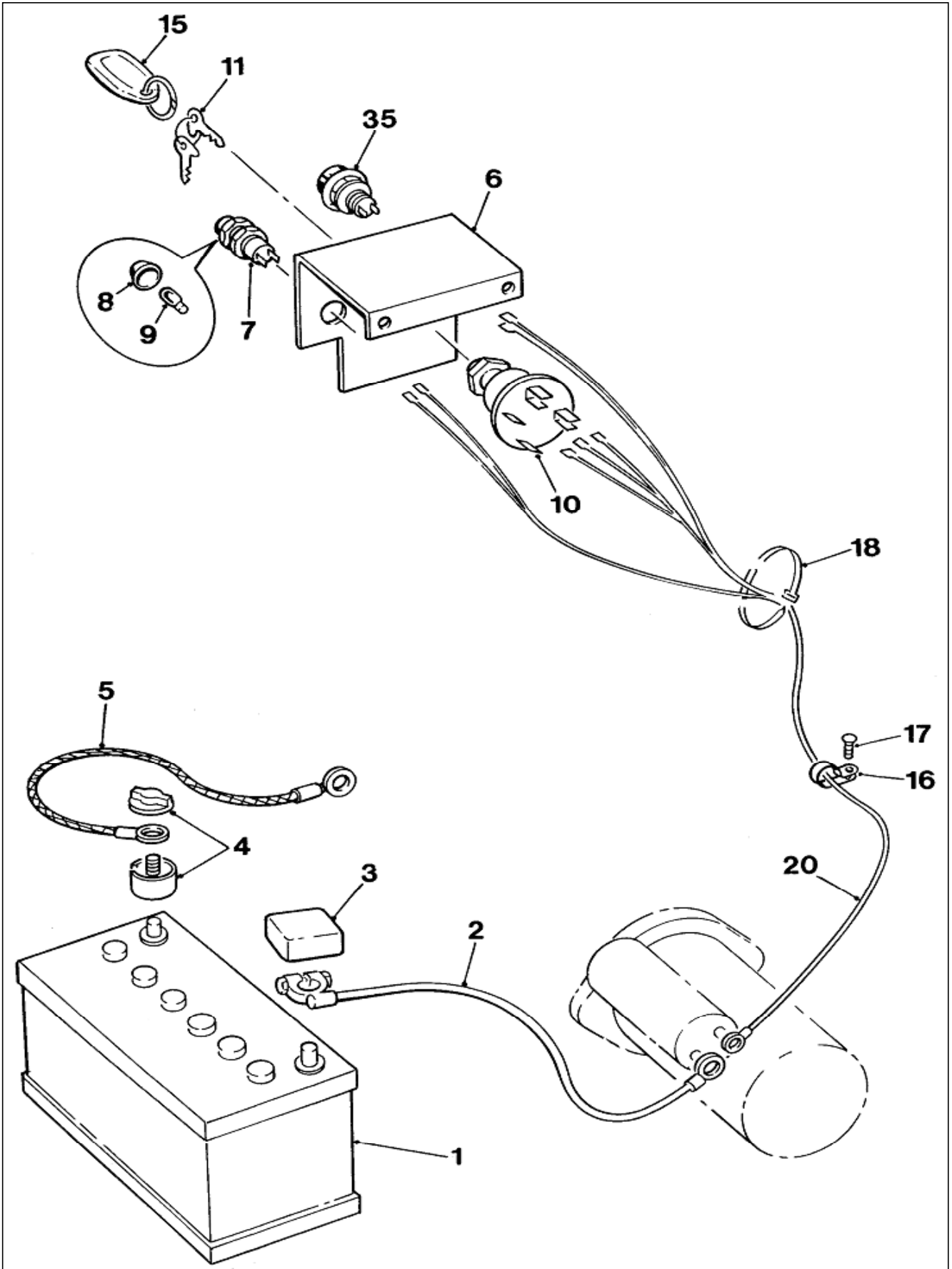



**MAIN ELECTRICAL CIRCUIT****F - 2**

<b>Item</b>	<b>Part no</b>	<b>Serial no</b>	<b>Description</b>	<b>Qty</b>
1	109S08		BATTERY	1
2	10989A06		CABLE, positive	1
3	V2004204		INSULATOR, battery positive terminal	1
4	V2004214		ISOLATOR, battery negative terminal	1
5	V2003510		CABLE, earth	1
6	20313A06		PANEL, instrument	1
7	V602634		LIGHT, battery charging	1
8	V602635		LENS	1
9	V602636		BULB	1
10	V2004189		SWITCH, key start	1
11	V601179		KEY, start switch	1
15	V2003540		RING, key	1
16	143200900		CLIP, cable	2
17	178SPS04C		SCREW, self-tapping	2
18	V2003111		TIE, cable	3
20	30231A11		LOOM, wiring	1

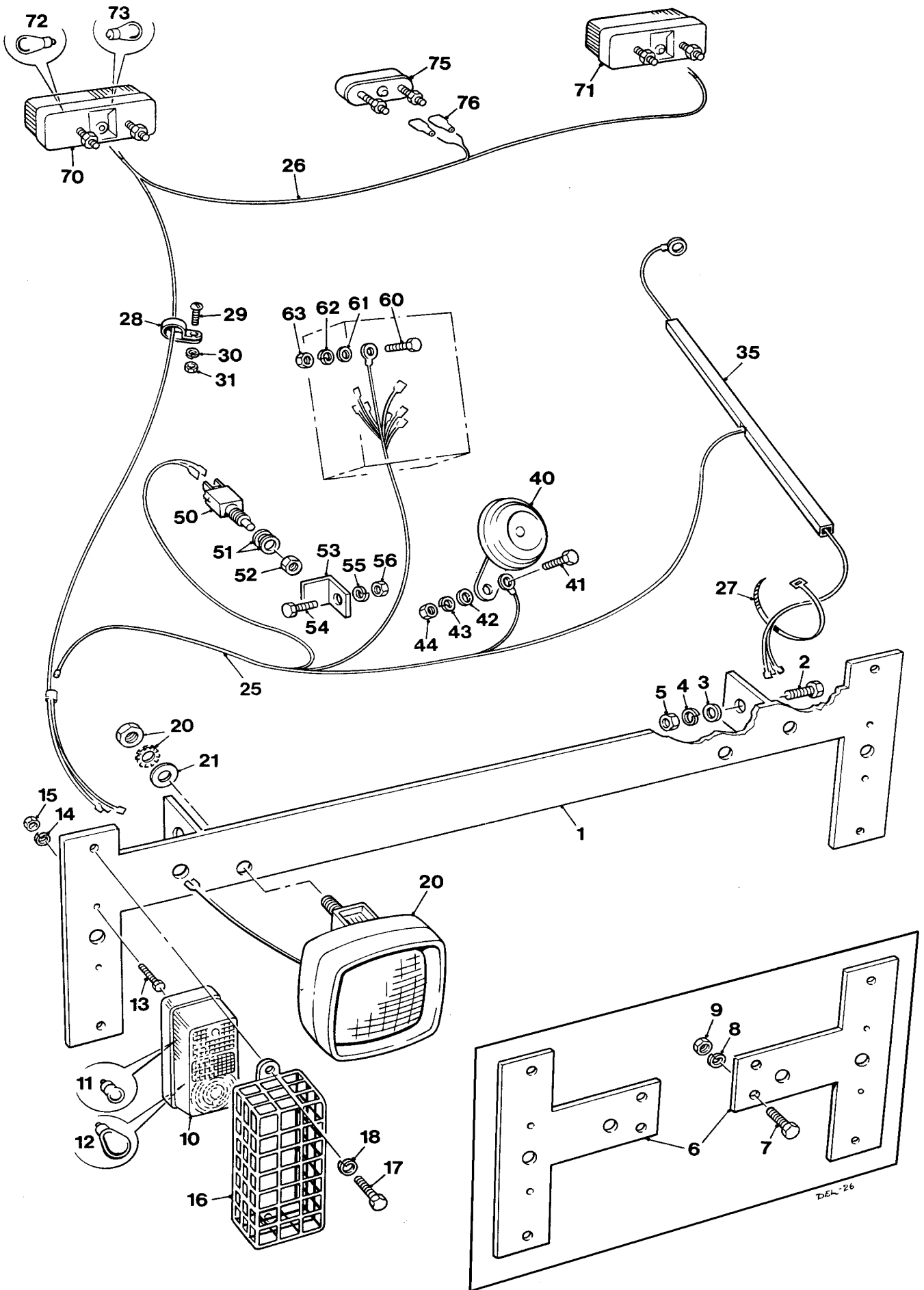

# ROAD LIGHTS

F - 3

Item	Part no	Serial no	Description	Qty
1	10973A03		BRACKET, front lights (hyd. tipping earth skips)	1
2	11S05F		SCREW, set	2
3	267S07		WASHER, flat	2
4	17S06		WASHER, spring	2
5	7S05		NUT	2
6	10973A04		BRACKET, front lights (gravity tip earth skips)	2
7	11S03E		SCREW, set	2
8	17S04		WASHER, spring	2
9	7S03		NUT	2
10	V2003652		LIGHTS, R.H. front, assembly	1
—	V2003637		LIGHTS, L.H. front, assembly ( <i>not ill.</i> )	1
11	—		BULB, sidelight 12V 5W	1
12	—		BULB, indicator 12V 21W	1
13	11S01C		SCREW, set	4
14	17S02		WASHER, spring	4
15	7S01		NUT	4
16	V2003158		GUARD	2
17	11S03AA		SCREW, set	4
18	17S04		WASHER, spring	4
20	V2003638		LIGHT, head, c/w nut & washer	2
21	V2004220		WASHER, Special	2
25	20105A15		LOOM, front	1
26	20105A14		LOOM, rear	1
27	V2003111		TIE, cable, 200mm long	8
27	V2003253		TIE, cable, 390mm long	4
28	143200900		CLIP, nylon	7
29	16S05B		SCREW	7
30	17S10		WASHER, spring	7
31	7S09		NUT	7
35	V2004043		CONDUIT	AR
40	V2003144		HORN	1
41	11S03B		SCREW, set	1
42	267S05		WASHER, flat	1
43	17S04		WASHER, spring	1
44	7S03		NUT	1
50	V2003168		SWITCH, brake lights	1
51	267S07		WASHER, flat	AR
52	95S05		NUT	1

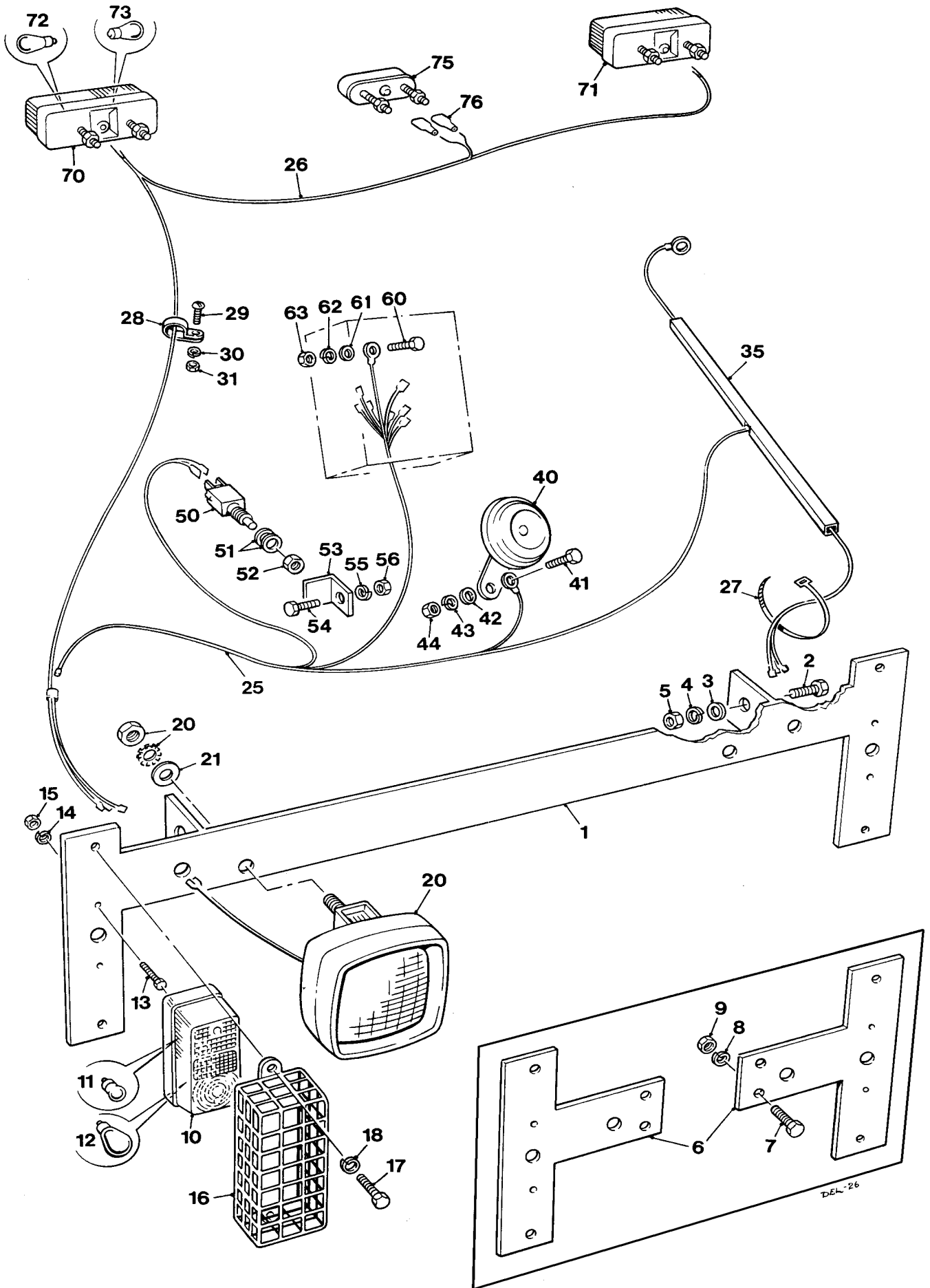

# ROAD LIGHTS

F - 3

Item	Part no	Serial no	Description	Qty
53	_____		BRACKET	1
54	11S03C		SCREW, set	1
55	17S04		WASHER, spring	1
56	7S03		NUT	1
60	11S03B		SCREW, set ( <i>console earth terminal</i> )	1
61	267S05		WASHER, flat	1
62	17S04		WASHER, spring	1
63	7S03		NUT	1
70	V2003651		LIGHT, R.H. rear, assembly	1
71	V2003636		LIGHT, L.H. rear, assembly	1
72	_____		BULB, indicator, 12V 21W	1
73	_____		BULB, brake/rear sidelight, 12V 21/5W	1
75	V2003639		LIGHT, number plate	1
76	191906000		CONNECTOR, 1/4" female Lucar	2
—	191901900		Four-way common contact connector ( <i>not illustrated</i> )	1

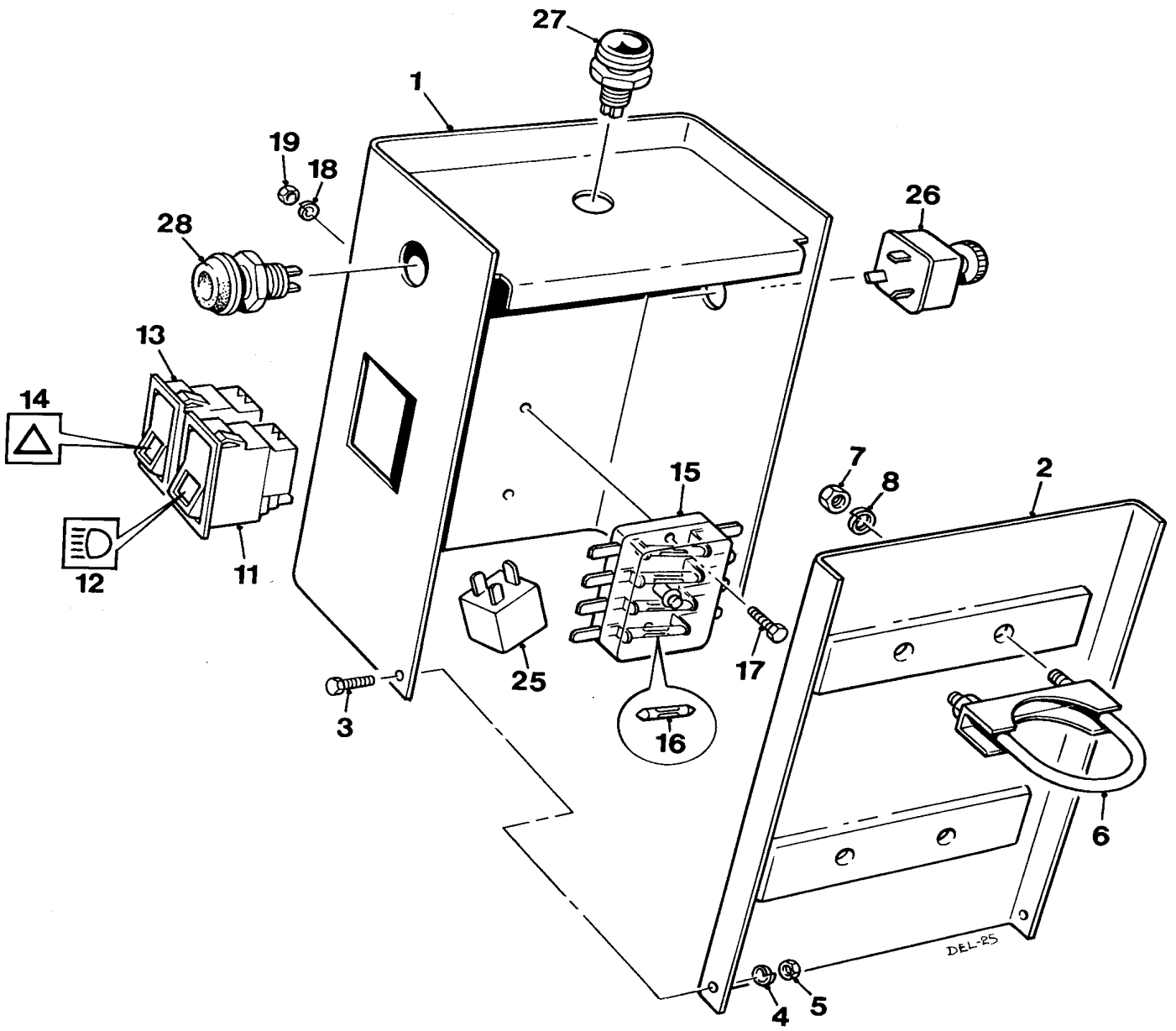

Item	Part no	Serial no	Description	Qty
1	30267A04		CONSOLE	1
2	20318A01		BACKPLATE, console	1
3	11S01AA		SCREW, set	2
4	17S02		WASHER, spring	2
5	7S01		NUT	2
6	153S05		CLAMP, ( <i>discard bracket</i> ) assembly	1
7	7S03		NUT	2
8	17S04		WASHER, spring	2
11	V2003644		SWITCH, lights	1
12	V2003646		INSERT, mainbeam	1
13	V2003641		SWITCH, hazard lights	1
14	V2003647		INSERT, hazard lights	1
15	V601177		FUSE BOX,	1
16	V601173		FUSE, blade, use with item 15	AR
17	11S01A		SCREW, set	2
18	17S02		WASHER, spring	2
19	7S01		NUT	2
25	V2003640		UNIT, flasher	2
26	V2003642		SWITCH, indicators	1
27	V2000326		LIGHT, indicator warning	1
28	V2003570		BUTTON, horn	1





# 2B1500 DUMPER

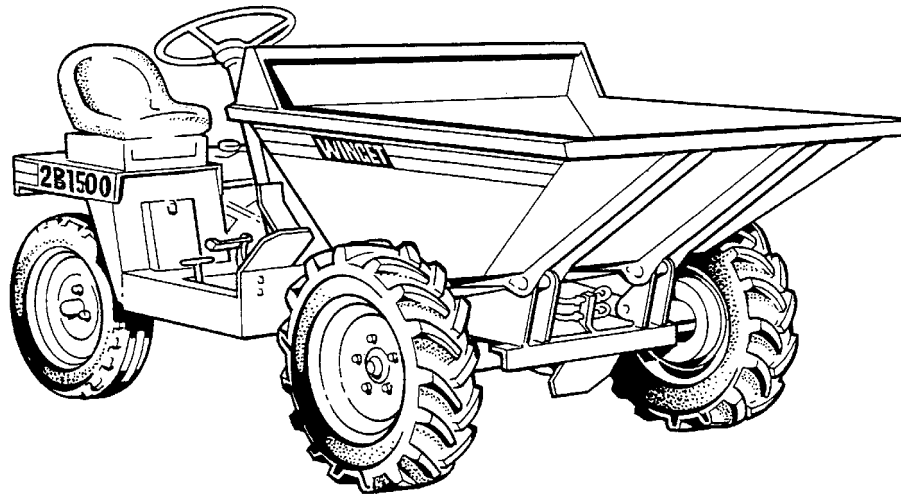



# *Hydraulics*

**HYD PUMP, TANK & STEER VALVE, HYD TIP** **H - 1**

---

**HYD PUMP, TANK & STEER VALVE, GRA TIP** **H - 1A**

---

**DIRECT DRIVE HYDRAULIC PUMP** **H - 1AA**

---

**SKIP TIPPING HYDRAULIC CIRCUIT** **H - 2**

---

**CONTROL VALVE.** **H - 3**

---

**RAM, STANDARD SKIP TIPPING, METRIC** **H - 4**

---

**RAM, STEERING** **H - 5**

---

**STEER COLUMN & VALVE** **H - 6**

---

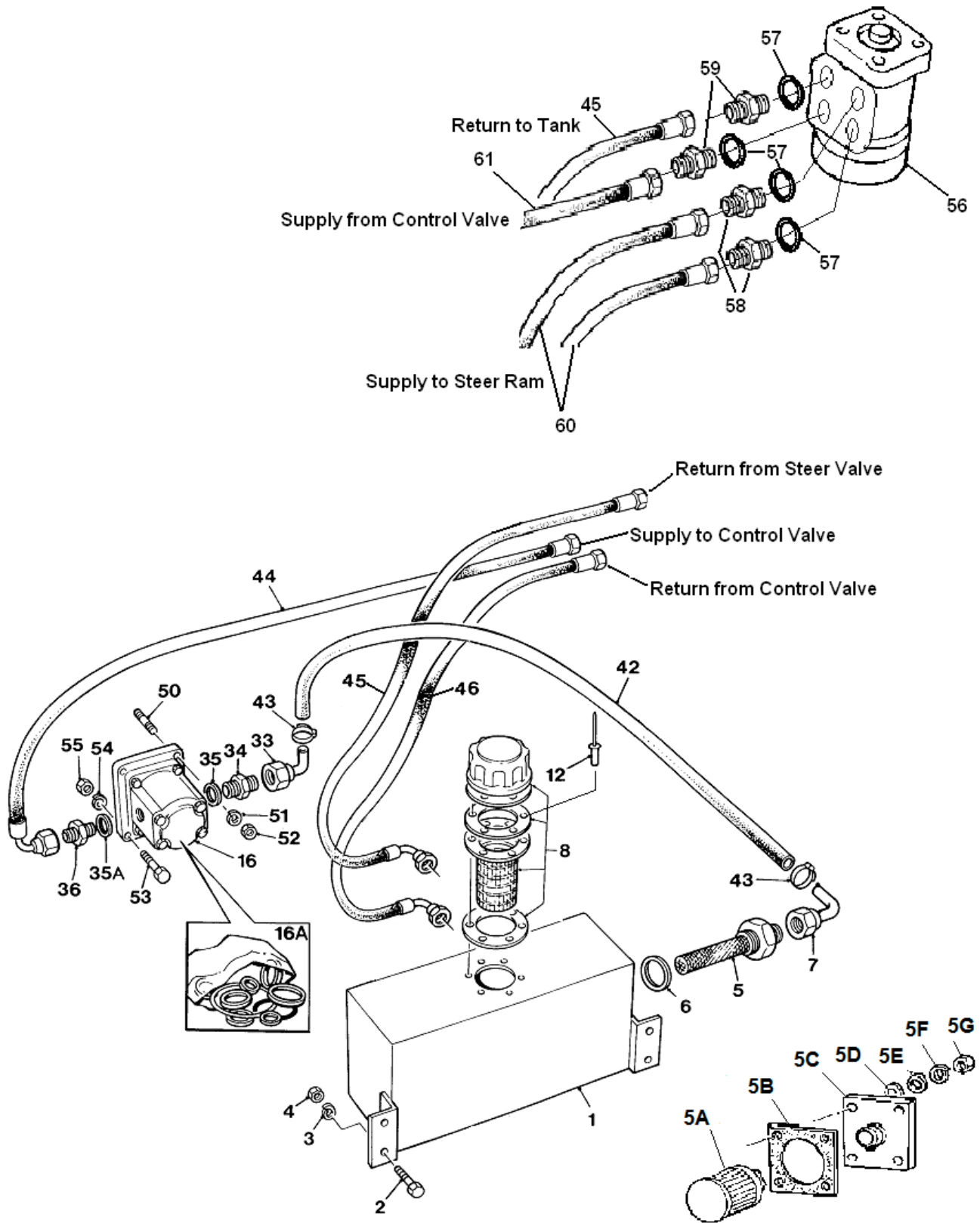

<b>Item</b>	<b>Part no</b>	<b>Serial no</b>	<b>Description</b>	<b>Qty</b>
1	30286A08		TANK, hydraulic	1
2	11S04C		SCREW	4
3	17S05		WASHER	4
4	7S04		NUT	4
5	901S02	/1232	FILTER, suction	1
5A	V2005355	1233/	FILTER, suction	1
5B	V2005356	1233/	GASKET	1
5C	V2006399	1233/	PLATE, filter mounting	1
5D	186S02	1233/	WASHER, nylon	4
5E	267S04	1233/	WASHER, flat	4
5F	17S03	1233/	WASHER, spring	4
5G	7S02	1233/	NUT	4
6	100S08	/1232	SEAL, bonded	1
7	129S05E		ELBOW	2
8	10565A01		CAP, filler, complete	1
12	101S07E		RIVET	6
16	10977A03		PUMP, "Ultra/Dowty" C/W Rrotation	1
16A	10190A01		KIT, pump repair, "Dowty" & "Ultra"	AR
<b>Refer to Page H-1AA for Direct Drive Hydraulic Pump</b>				
33	129S05E		ELBOW	1
34	119S13		ADAPTOR, m/m unequal	1
35	100S04		SEAL, bonded	1
35A	100S04		SEAL, bonded	1
36	119S08		ADAPTOR, m/m unequal	1
42	37S01K		HOSE, 600mm long	1
43	V2003232		CLIP, hose	2
44	31S02V		HOSE, pump to control valve	1
45	31S02O		HOSE, tank return from steer valve	1
46	31S02AA		HOSE, tank return from control valve	1
<b>Item 50 refer to TR Engine Parts Manual</b>				
50	—		STUD	1
51	17S05		WASHER, spring	1
52	7S03		NUT	1
53	8S03C		BOLT	3
54	17S05		WASHER, spring	3
55	7S03		NUT	3
56	—		VALVE, steer, see Page H6	1
57	100S04		SEAL, bonded	4
58	119S04		ADAPTOR, m/m unequal	2
59	119S08		ADAPTOR, m/m unequal	2
60	321S01G		HOSE, steer valve to steer ram	2
61	31S02O		HOSE, control valve to steer valve	1

**Note:- Hoses to/from Steer Valve route down inside of R.H. chassis leg**

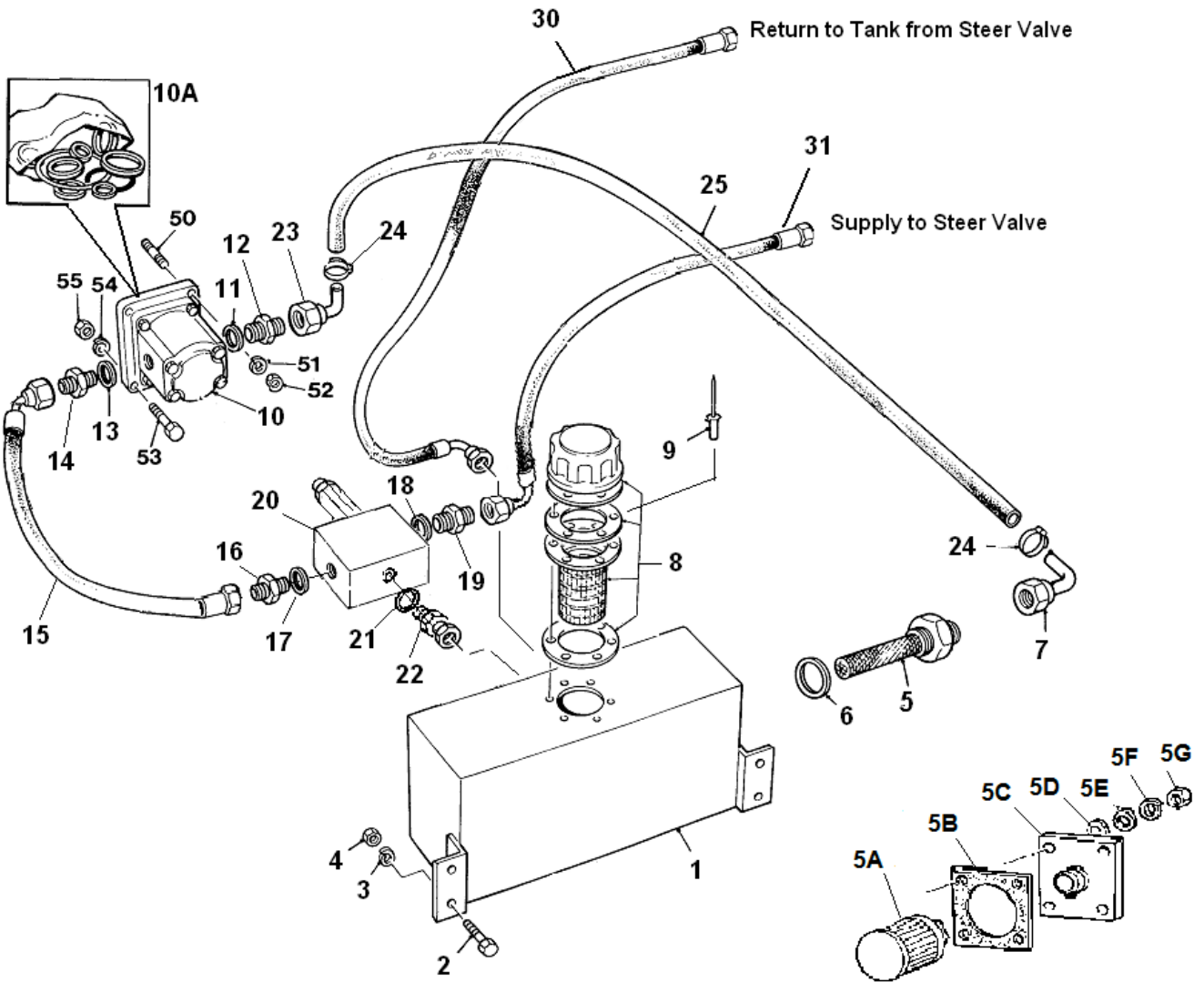
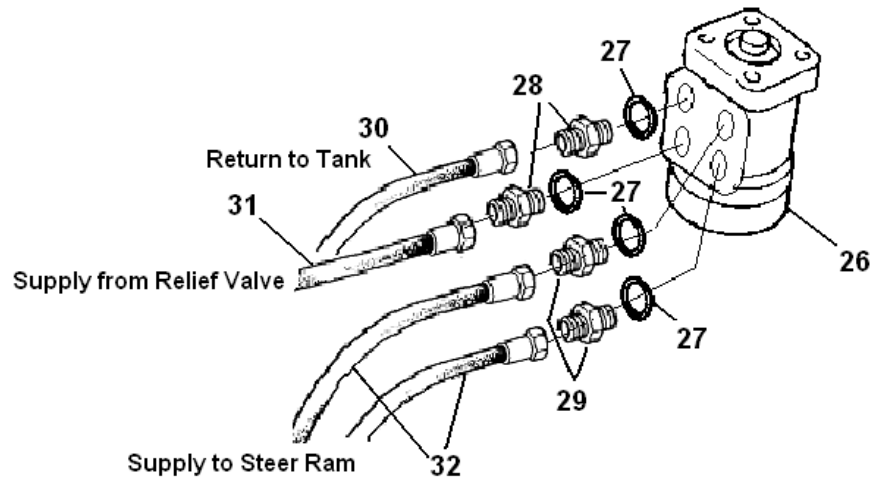

# HYDRAULIC PUMP, TANK & STEER VALVE GRAVITY TIP

# H - 1A

Item	Part no	Serial no	Description	Qty
1	30286A08		TANK, hydraulic	1
2	11S04C		SCREW	4
3	17S05		WASHER	4
4	7S04		NUT	4
5	901S02	/1232	FILTER	1
5A	V2005355	1233/	FILTER, suction	1
5B	V2005356	1233/	GASKET	1
5C	V2006399	1233/	PLATE, filter mounting	1
5D	186S02	1233/	WASHER, nylon	4
5E	267S04	1233/	WASHER, flat	4
5F	17S03	1233/	WASHER, spring	4
5G	7S02	1233/	NUT	4
6	100S08	/1232	SEAL, bonded	1
7	129S05E		ELBOW	2
8	10565A01		CAP, filler, complete	1
9	101S07E		RIVET	6
10	10977A03		PUMP, "Ultra/Dowty" C/W Rotation	1
10A	10190A01		KIT, pump repair, "Dowty" & "Ultra"	AR
<b>Refer to Page H-1AA for Direct Drive Hydraulic Pump</b>				
11	100S04		SEAL, bonded	1
12	119S13		ADAPTOR	1
13	100S04		SEAL, bonded	1
14	119S08		ADAPTOR, m/m unequal	1
15	31S02AA		HOSE, pump to relief valve	1
16	122S03		ADAPTOR, m/m equal	1
17	100S03		SEAL, bonded	1
18	100S03		SEAL, bonded	1
19	122S03		ADAPTOR, m/m equal	1
20	V2006357		VALVE, relief	1
21	100S03		SEAL, bonded	1
22	112S07		ADAPTOR, m/f swivel	1
23	129S05E		ELBOW	1
24	V2003232		CLIP, hose	2
25	37S01K		HOSE, 600mm long	1
26	—		VALVE, steer, see Page H6	1
27	100S04		SEAL, bonded,	4
28	119S08		ADAPTOR, m/m unequal	2
29	119S04		ADAPTOR, m/m unequal	2
30	31S02O		HOSE, tank return from steer valve	1
31	31S02O		HOSE, relief valve to steer valve	1
32	321S01G		HOSE, steer valve to steer ram	2

**Note:- Hoses to/from Steer Valve route down inside of R.H. chassis leg**

Continued>>>

# H - 1A

# 2B1500 Dumper

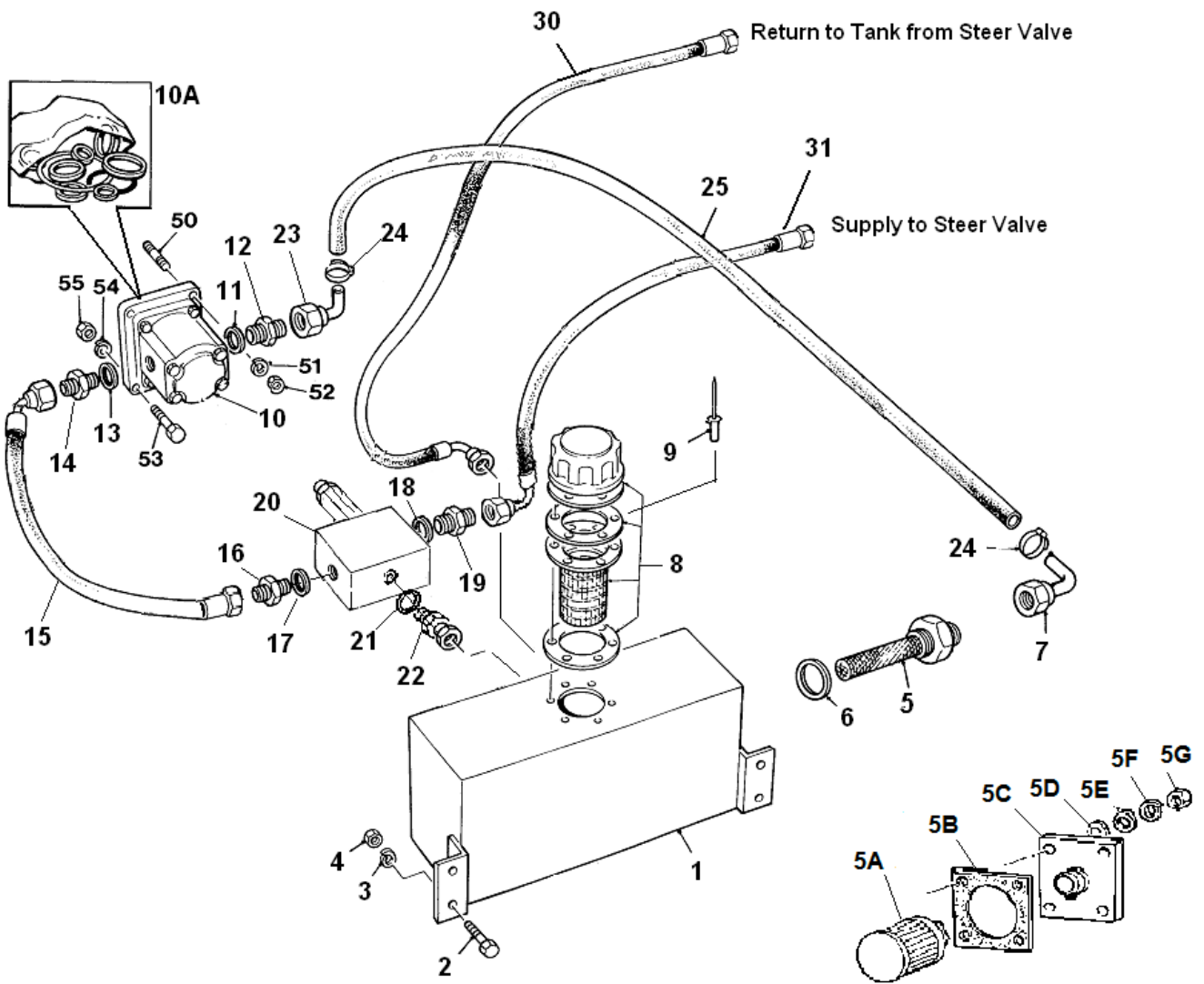
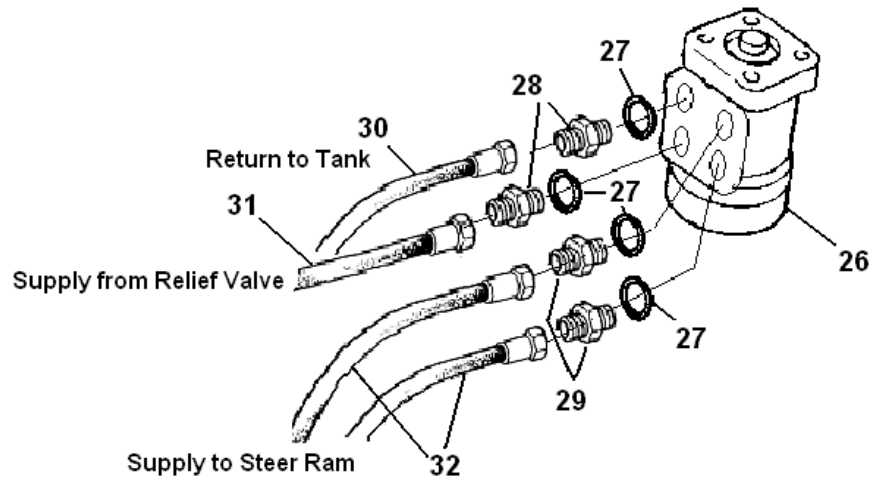



# HYDRAULIC PUMP, TANK & STEER VALVE GRAVITY TIP

# H - 1A

Item	Part no	Serial no	Description	Qty
			<b>Item 50 refer to TR Engine Parts Manual</b>	
50	---		STUD	1
51	17S05		WASHER, spring	1
52	7S03		NUT	1
53	8S03C		BOLT	3
54	17S05		WASHER, spring	3

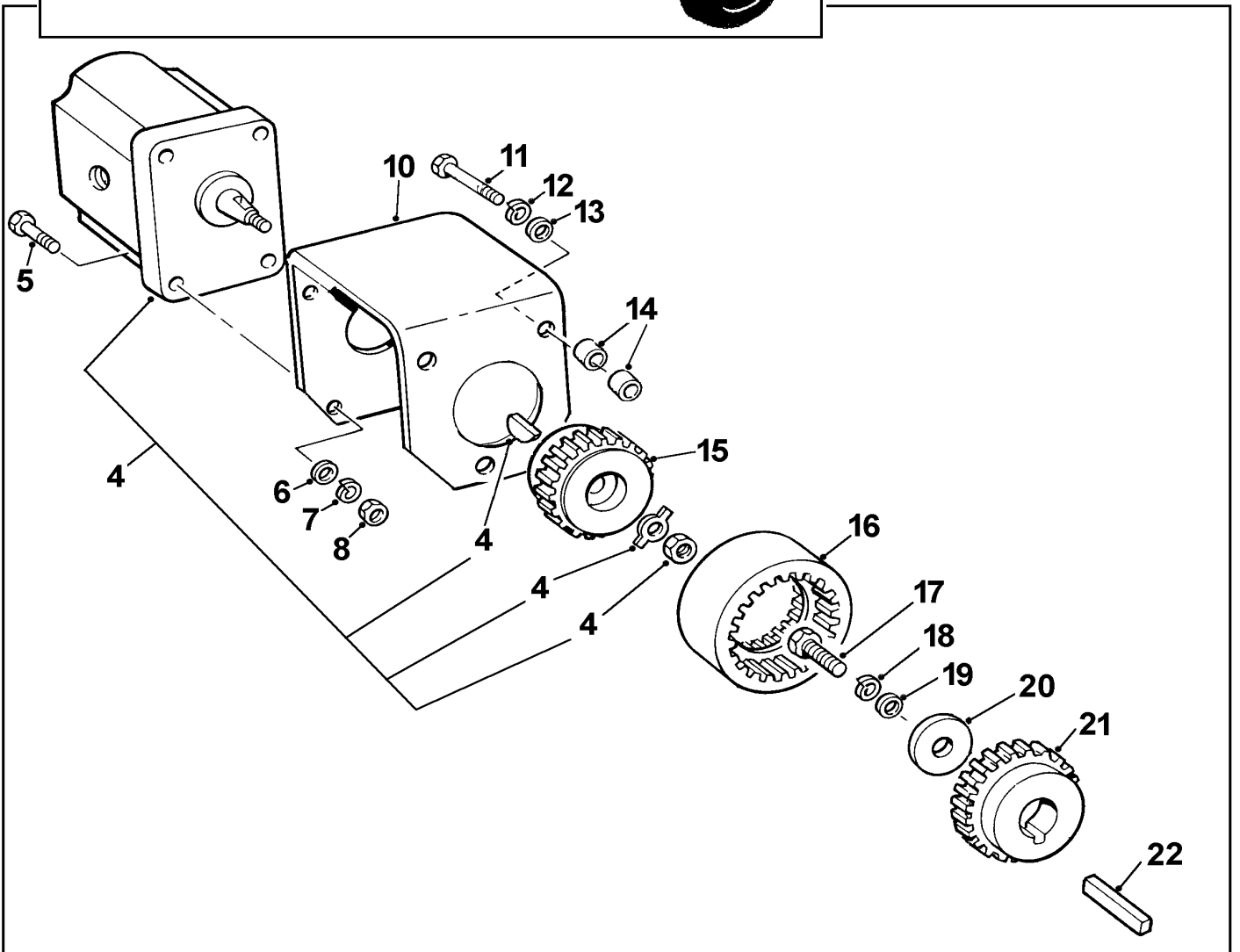
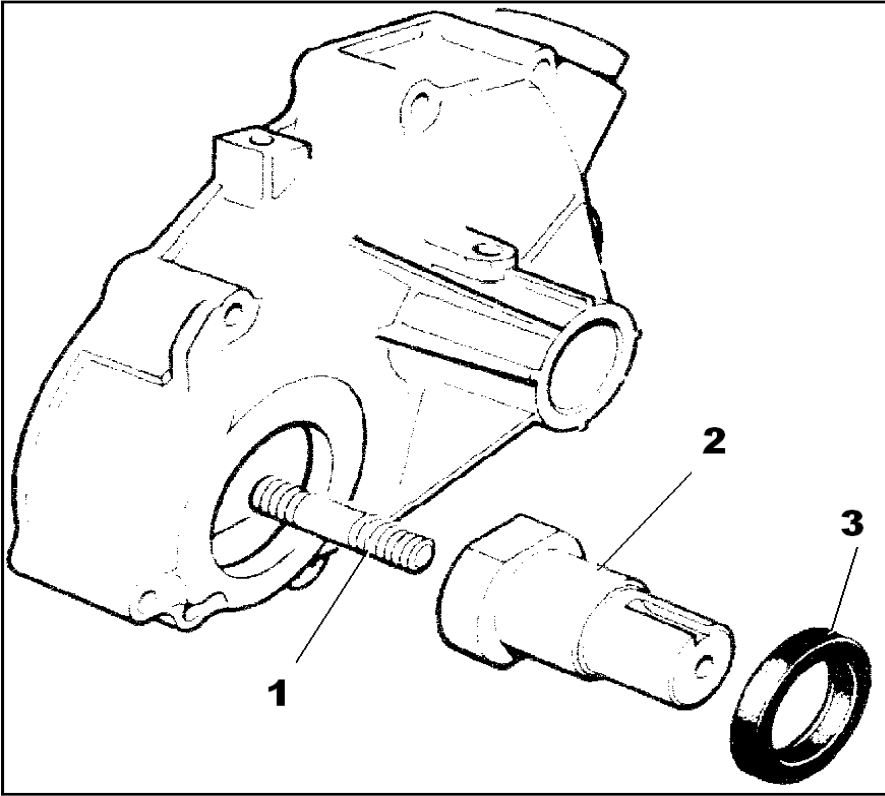

**DIRECT DRIVE HYDRAULIC PUMP****H - 1AA**

<b>Item</b>	<b>Part no</b>	<b>Serial no</b>	<b>Description</b>	<b>Qty</b>
1	V2006390		STUD	1
2	V2006381		EXTENSION SHAFT, pump drive	1
3	417732500		SEAL, oil	1
4	10977A06		HYDRAULIC PUMP A/C, assembly	1
5	8S02C		BOLT	4
6	267S04		WASHER, flat	4
7	17S03		WASHER, spring	4
8	7S02		NUT	4
10	V2006385		BRACKET, pump mounting	1
11	8S03N		BOLT	3
12	17S04		WASHER, spring	3
13	267S05		WASHER, flat	3
14	513340800		SPACER	6
15	V2006383		COUPLING, driven half, pump	1
16	V603660		SLEEVE COUPLING, nylon	1
	V2006389		COUPLING ASSEMBLY	1
			<b><i>consists of items 15, 16 &amp; 21</i></b>	1
17	11S03B		SCREW, set	1
18	17S04		WASHER, spring	1
19	267S05		WASHER, flat	1
20	V2004220		WASHER SPECIAL, flat	1
21	V2006384		COUPLING, drive half, engine shaft	1
22	305110550		KEY, parallel	1

***Following Parts are not Illustrated***

23	V2006388		GUARD, coupling	1
24	11S03B		SCREW, set	1
25	17S04		WASHER, spring	1
26	267S05		WASHER, flat	1

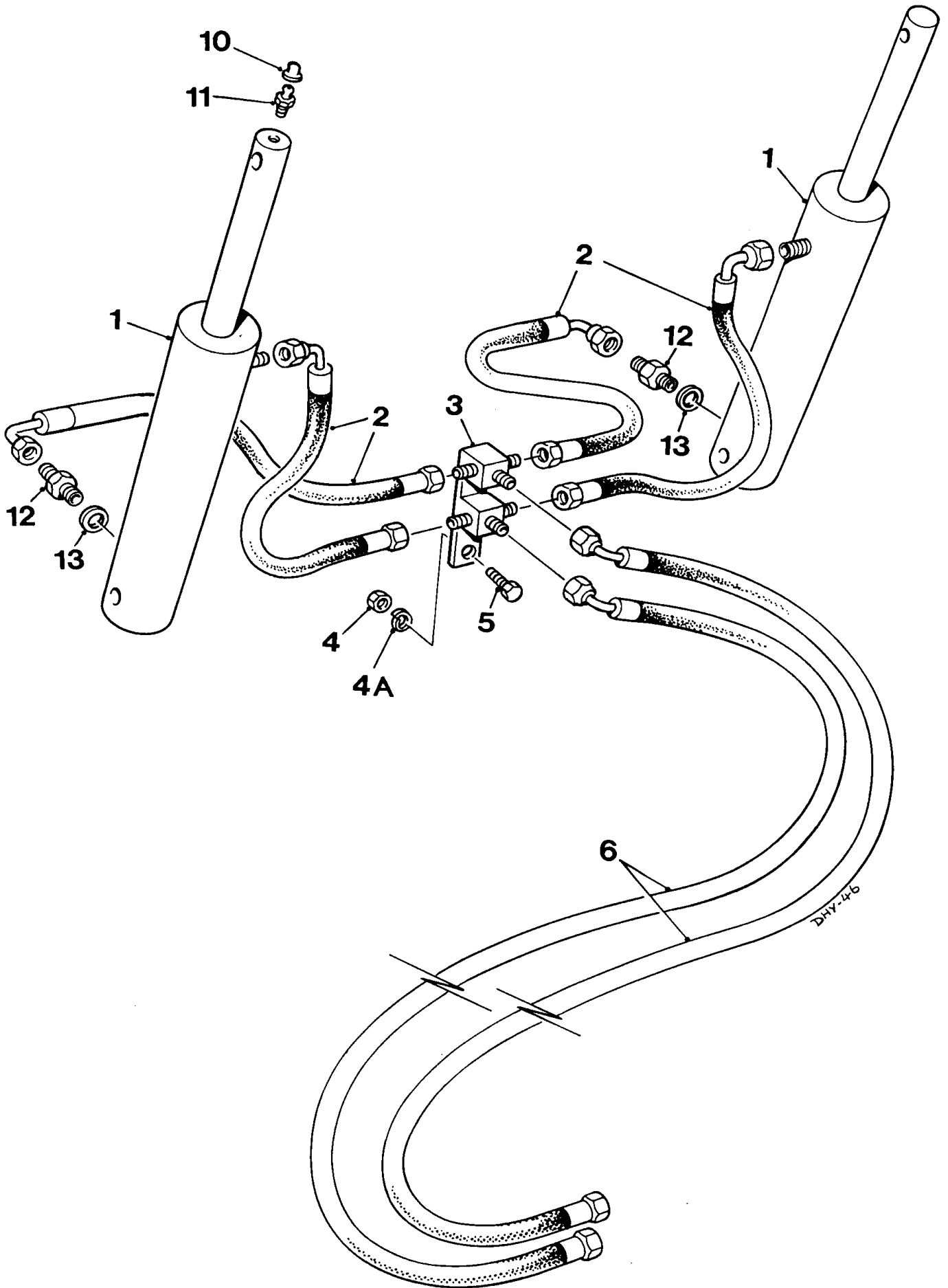

# SKIP TIPPING HYDRAULIC CIRCUIT

## H - 2

Item	Part no	Serial no	Description	Qty
1	30287A06		RAM (see page H-4)	2
2	31S02GG		HOSE	4
3	10464A02		FITTING, double tee bracket	1
4	7S03		NUT	1
4A	17S04		WASHER, spring	1
5	11S03E		SCREW, set	1
6	31S02YY		HOSE	2
10	176S01		CAP, grease nipple	4
11	131S01		NIPPLE, grease, straight	2
—	131S02		NIPPLE, grease, 90 deg.	2
12	122S03		ADAPTOR, m/m	2
12A	127S03		PLUG, blank	2
13	100S03		SEAL, bonded	4

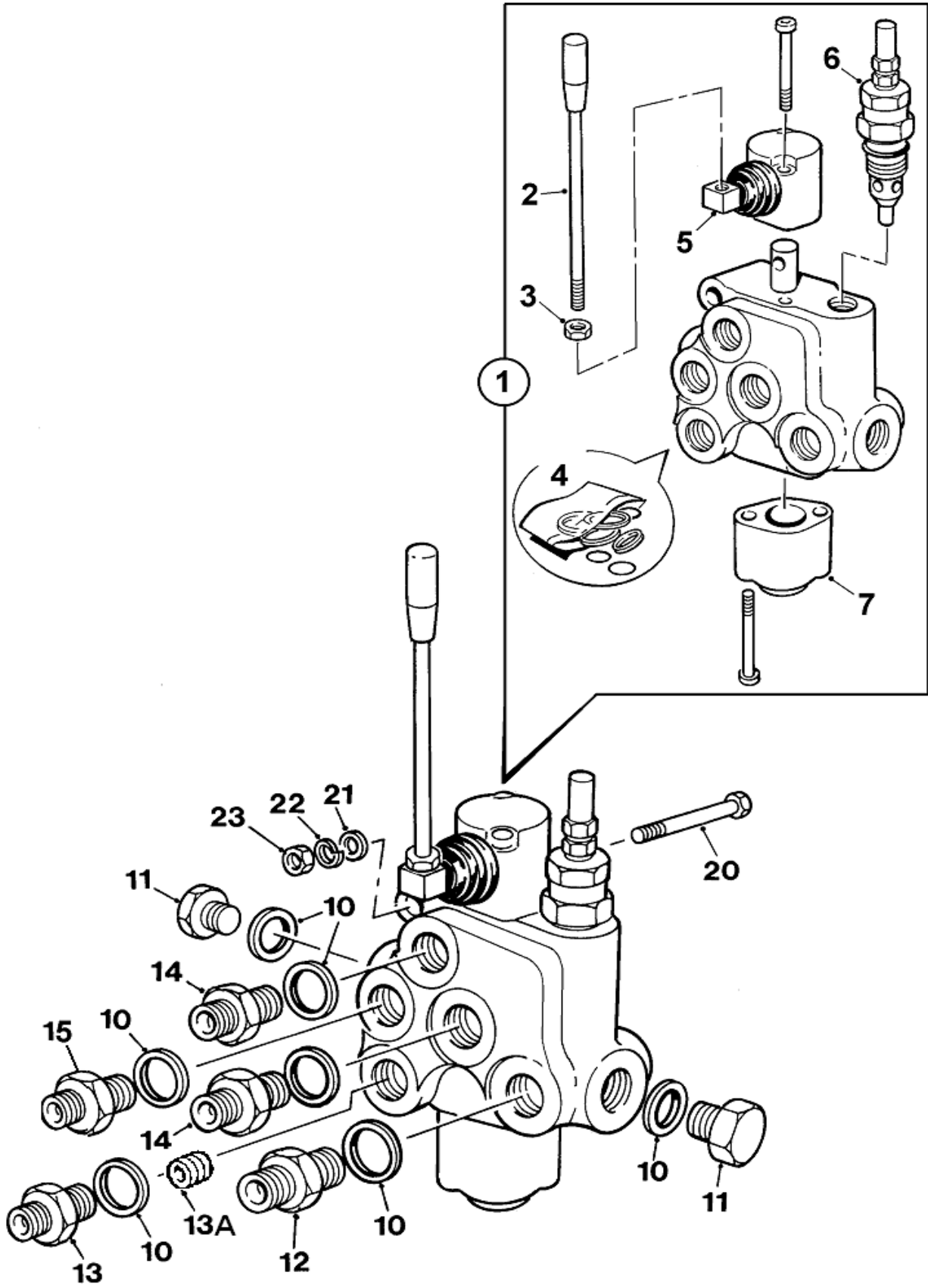

**CONTROL VALVE,****H - 3**

<b>Item</b>	<b>Part no</b>	<b>Serial no</b>	<b>Description</b>	<b>Qty</b>
1	V2004106		VALVE, control, assembly	
2	V602630		LEVER, knob & nut, assembly	1
3	7S04		NUT	1
4	V602629		KIT, control valve repair	AR
5	V603565		END CAP, lever	1
6	V603605		VALVE, relief	1
7	V603606		END CAP, spring base	1
10	100S03		SEAL, bonded	7
11	127S03		PLUG, male	2
12	122S03		ADAPTOR, m/m, supply from pump	1
13	122S03		ADAPTOR, m/m, to steering valve	1
13A	V2004607		PLUG, H.P.C.O.	1
14	93S01		ADAPTOR, bulkhead m/m, to tip rams	2
15	122S03		ADAPTOR, m/m, return to tank	1
20	8S03H		BOLT	2
21	267S05		WASHER, flat	2
22	17S04		WASHER, spring	2
23	7S03		NUT	2

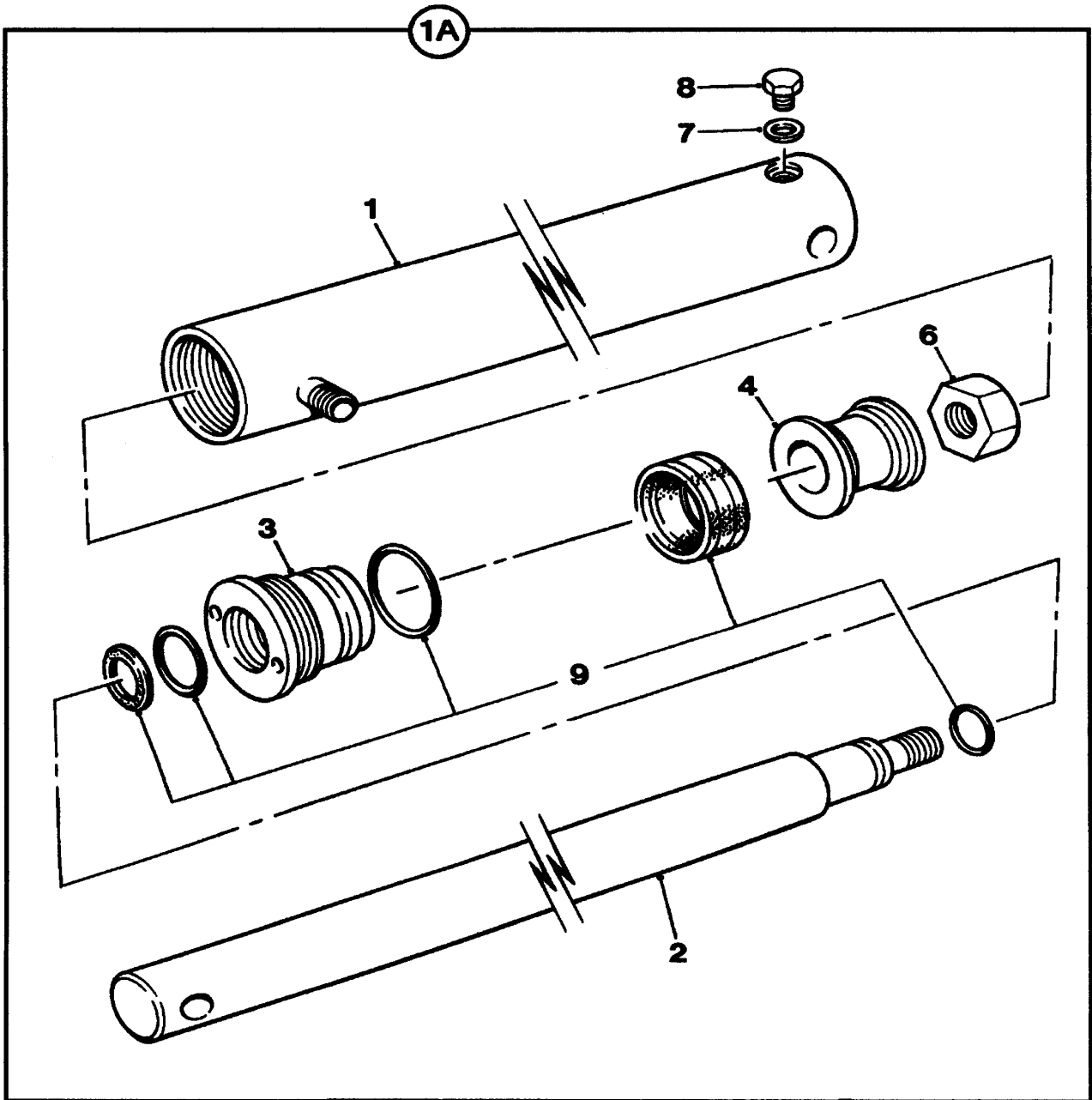



**RAM, (METRIC) tipping, hydraulic skip****H - 4**

<b>Item</b>	<b>Part no</b>	<b>Serial no</b>	<b>Description</b>	<b>Qty</b>
1A	30287A06		RAM, hyd, assembly, metric rod & cy	1
1	30287A0601		CYLINDER, ram (metric)	1
2	30287A0602		ROD, piston (metric)	1
3	30287A0603		NUT, gland ring	1
4	30287A0604		PISTON, one piece	1
5	30287A0605		Spacer, rod, not illustrated	1
6			NUT, nylon insert M20x1.5	1
6A	54S04K		Pin, tension M5x30	1
7	100S03		SEAL, bonded	1
8	127S03		PLUG, blanking	1
9	10558A11		KIT, seals	1

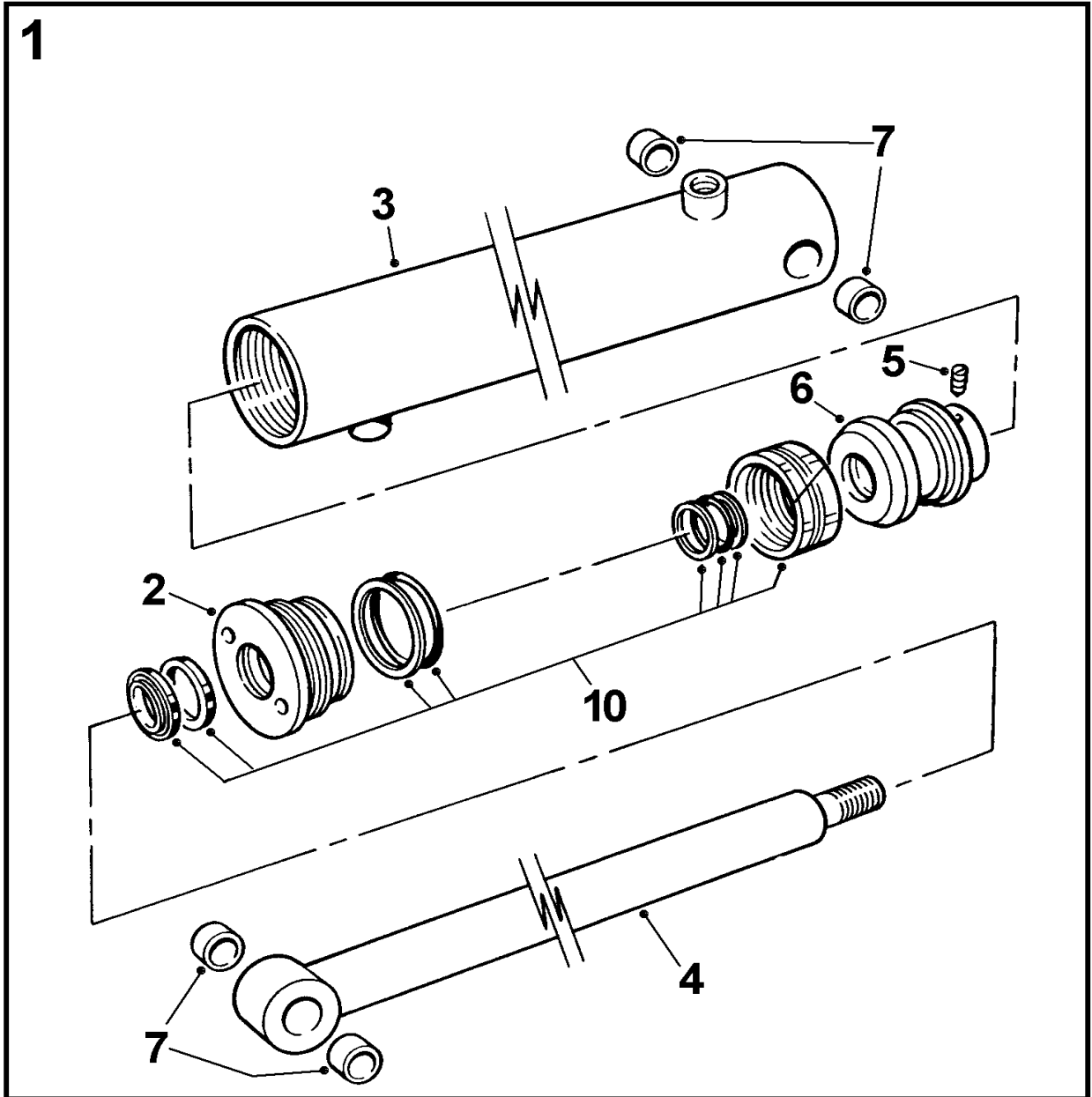

**RAM, steering****H - 5**

<b>Item</b>	<b>Part no</b>	<b>Serial no</b>	<b>Description</b>	<b>Qty</b>
1	V2005330		RAM, assembly steering	1
2	V603576		RETAINER, cylinder	1
3	V603577		CYLINDER	1
4	V603578		ROD	1
5	V603579		SCREW, grub	1
6	V603580		PISTON	1
7	V603013		BUSH	4
10	V603574		KIT, seals	1

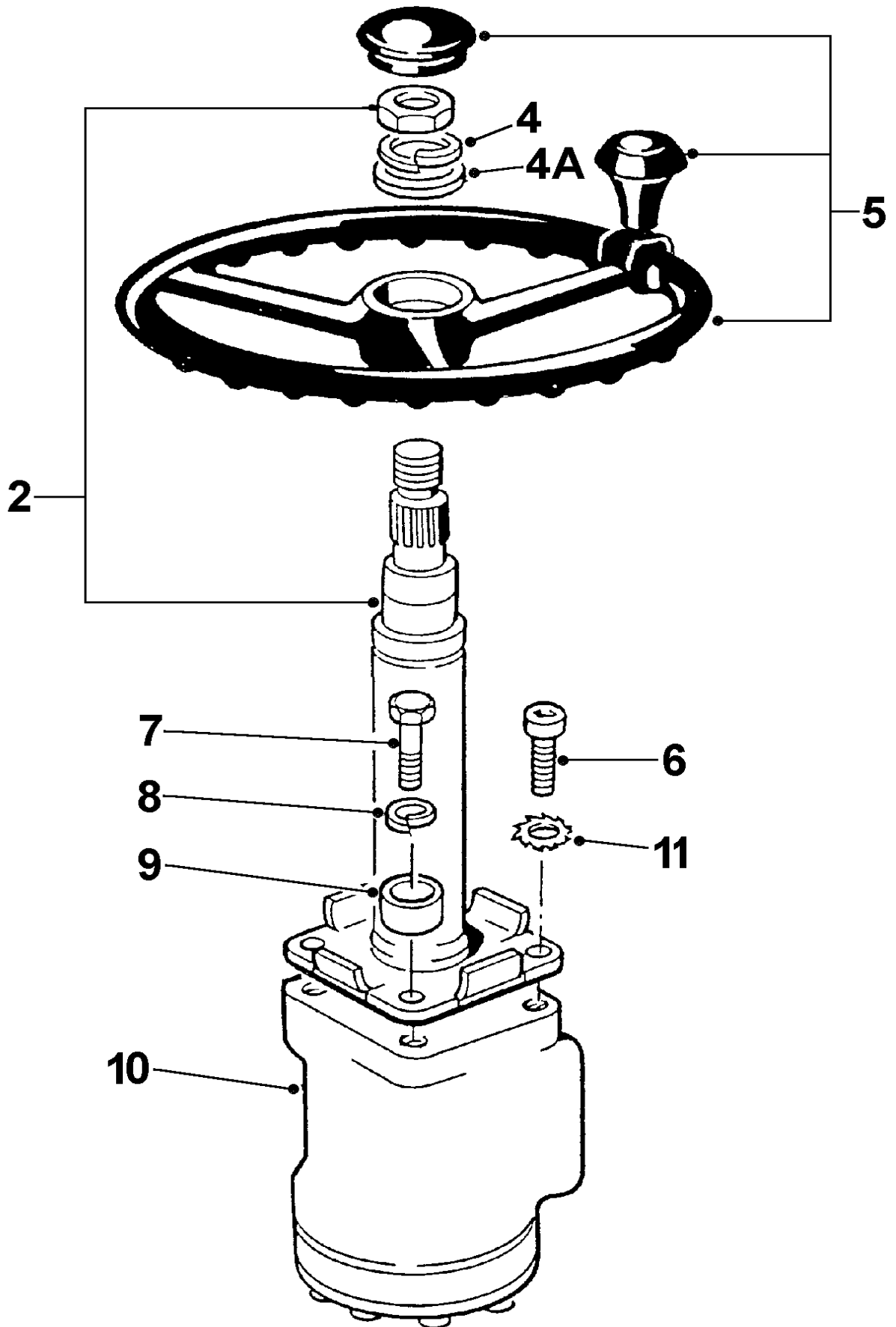

**STEER COLUMN & VALVE****H - 6**

<b>Item</b>	<b>Part no</b>	<b>Serial no</b>	<b>Description</b>	<b>Qty</b>
2	V2002872		COLUMN, steering	1
4	17S08		WASHER, spring	1
4A	267S09		WASHER, flat	1
5	V2004152		WHEEL, steering c/w spinner	1
6	68S05C		SCREW, socket cap	1
7	8S04C		BOLT	3
8	17S05		WASHER, spring	3
9	CSE182		SPACER	3
10	V2006352		VALVE, steering	
10A			KIT, seals	1
11	13S04		WASHER, shakeproof	1



# 2B1500 DUMPER

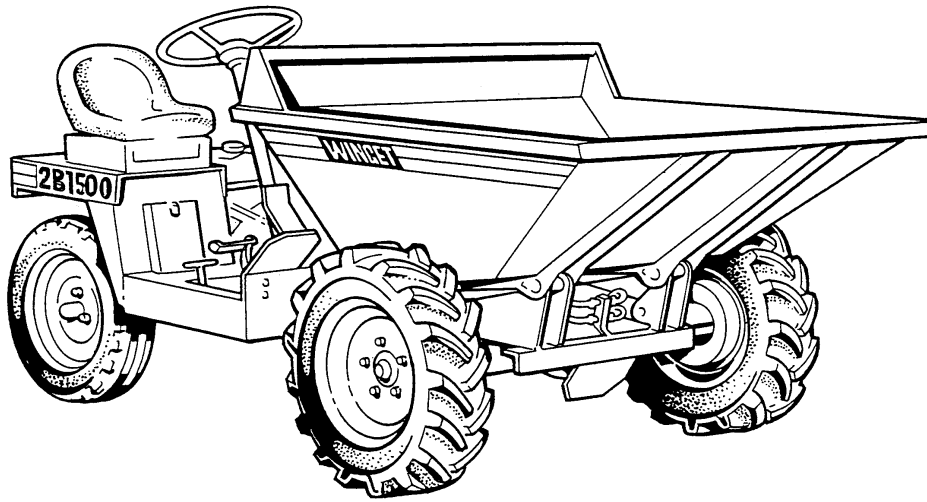





# ***Miscellaneous***

**DECALS & PLATES**

**J - 1 to J - 3**

---

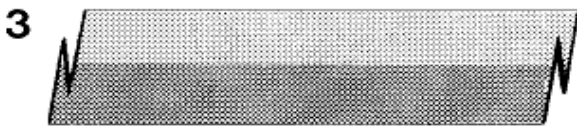

11

<b>WINGET</b> WINGET LIMITED P.O. Box 41, Stonehouse Lane, Bolton, Lancs, BL4 0LS Tel: 01204 883163 Fax: 01204 883206			
Model	_____		
Serial No.	_____		
Engine No.	_____		
Capacity	Mass (kg)	_____	
SRO No.	Power (kW)	_____	
Year Of Manuf.	Eng. (rpm)	Drum (rpm)	_____

A Sverdrup Group Company

12

**TAKE EXTRA CARE WHEN TIPPING  
NON FREE RUNNING LOADS**



16

**WARNING**  
DO NOT WORK UNDER  
UNPROPPED SKIP

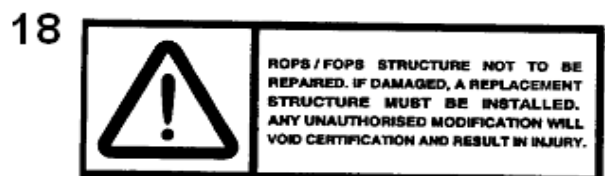
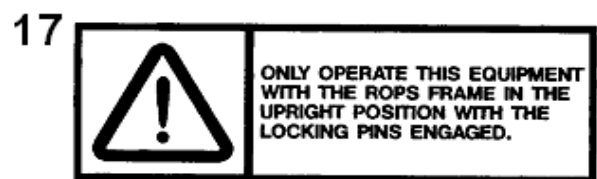

19

<b>TYPE CERTIFICATION FOR ROLL OVER AND FALLING OBJECT PROTECTIVE STRUCTURE</b>		TESTED TO STANDARDS: ROPS: ISO 3471/1984 SAE J1046/1988
MANUFACTURED BY: WINGET LTD, PO BOX 41, BOLTON, BL4 0LS. TEL: 01204 883163 FAX: 01204 883206	FOR APPLICATION ON: WINGET LTD, PO BOX 41, BOLTON, BL4 0LS. VEHICLE MODEL:	CAB FRAME SERIAL No. _____ 
MAXIMUM VEHICLE MASS:	_____	KGS.

Item	Part no	Serial no	Description	Qty
—	V601779		KIT, decals, <b>2B1500</b>	1 kit
			Each kit contains all decals required for one dumper	
1	V2003100		DECAL, Hydraulic oil	1
2	V2003101		DECAL, Diesel fuel	1
3	V2003038		DECAL, Stripe, bodywork,	3
4	V2003039		DECAL, Winget logo	3
10	10284A01		DECAL, Dump/return	1
11	V2003037		PLATE , Serial Number	1
12	10536A02		DECAL, Non free running loads	1
15	V2004235		DECAL, Negative earth	1
16	DM157		DECAL, Skip warning	1
17	V2005310		DECAL, R.O.P.S. folding#	1
18	V2004754		DECAL, Damage to R.O.P.S. frame#	1
19	V2005030		PLATE, R.O.P.S. identification#	1
.....	101S05D		RIVET, used with items 11& 19.	4

**# Items are not supplied in decal kit**

# 1 2B 1500

**3**

RECOMMENDED LUBRICATING OILS						
COMPANY	ENGINE	DRIVE AXLE	TRANSFER BOX	GEARBOX	HYDRAULIC SYSTEM	HYDRAULIC SYSTEM
Shell Castrol Mobil	Shell Castrol Mobil	Shell Castrol Mobil	Shell Castrol Mobil	Shell Castrol Mobil	Shell Castrol Mobil	Shell Castrol Mobil
Shell Castrol Mobil	Shell Castrol Mobil	Shell Castrol Mobil	Shell Castrol Mobil	Shell Castrol Mobil	Shell Castrol Mobil	Shell Castrol Mobil
Shell Castrol Mobil	Shell Castrol Mobil	Shell Castrol Mobil	Shell Castrol Mobil	Shell Castrol Mobil	Shell Castrol Mobil	Shell Castrol Mobil
Shell Castrol Mobil	Shell Castrol Mobil	Shell Castrol Mobil	Shell Castrol Mobil	Shell Castrol Mobil	Shell Castrol Mobil	Shell Castrol Mobil
Shell Castrol Mobil	Shell Castrol Mobil	Shell Castrol Mobil	Shell Castrol Mobil	Shell Castrol Mobil	Shell Castrol Mobil	Shell Castrol Mobil
Shell Castrol Mobil	Shell Castrol Mobil	Shell Castrol Mobil	Shell Castrol Mobil	Shell Castrol Mobil	Shell Castrol Mobil	Shell Castrol Mobil

IN THE UNLIKELY EVENT OF THE ABOVE OILS NOT BEING AVAILABLE EQUIVALENT OILS SUPPLIED BY A REPUTABLE MANUFACTURER MAY BE USED.

**19**

## SAFETY WARNING

- 1 Before starting this machine, the operator should be familiar with the operating instructions issued by the manufacturer.
- 2 The manufacturer's rated capacity must never be exceeded.
- 3 Before carrying out any maintenance, servicing, or greasing, always ensure that the engine has been switched off. Never work on a machine while it is running.

W504694600

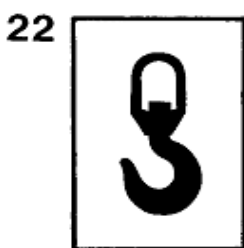
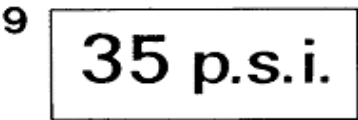

**15**

Top up with Hydraulic Oil ONLY  
DO NOT use Brake Fluid



## DECALS &amp; PLATES

J - 2

Item	Part no	Serial no	Description	Qty
1	V2003153		DECAL, 2B1500	2
3	DM197		DECAL, Lubrication oils	1
7	V2003142		DECAL, Warning - wheel nuts	1
9	10540A02		DECAL, 35psi tyre pressure	4
15	10848A01		DECAL, Brake fluid	1
17	V2004472		DECAL, Max. payload 1500kgs	1
19	504694600		DECAL, Safety warning	1
20	V2003598		DECAL, British made	1
22	V2003665		DECAL, Lift here	2

**# Items not supplied in decal kit**

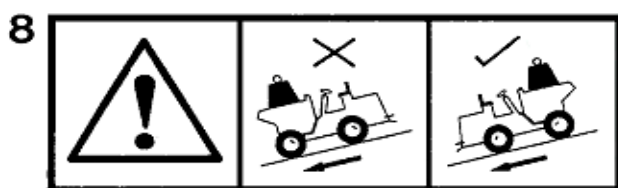
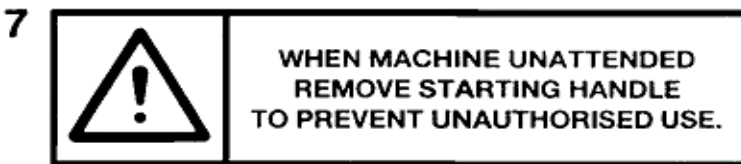
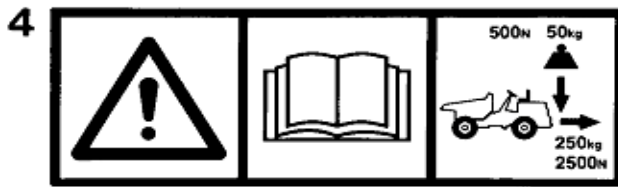
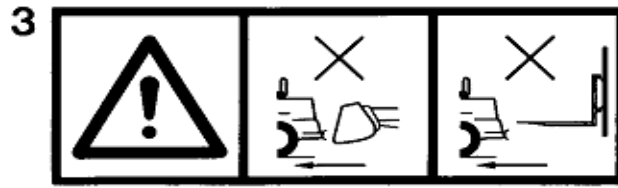
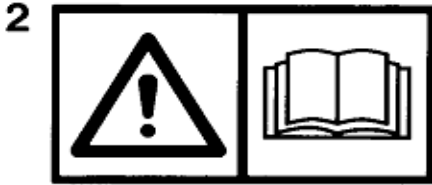

**DECALS & PLATES****J - 3**

<b>Item</b>	<b>Part no</b>	<b>Serial no</b>	<b>Description</b>	<b>Qty</b>
1	V2004227		DECAL, Battery isolator	1
2	V2004229		DECAL, Operators handbook	1
3	V2004245		DECAL, No buckets, No forks	1
4	V2004244		DECAL, Towbar loadings	1
5	V2004282		DECAL, Hot surfaces	1
6	V2004307		DECAL, Electrical hazard	1
7	V2004288		DECAL, Starting handle	1
8	V2004450		DECAL, Gradients	1
13	V2004744		DECAL, Eye protection	1
15	V2005126		DECAL, Heaped load	1





# CALIFORNIA

## Proposition 65 Warning

**Diesel engine exhaust and some of its constituents are known to the State of California to cause cancer, birth defects, and other reproductive harm**

