

DUMPER 4B2000

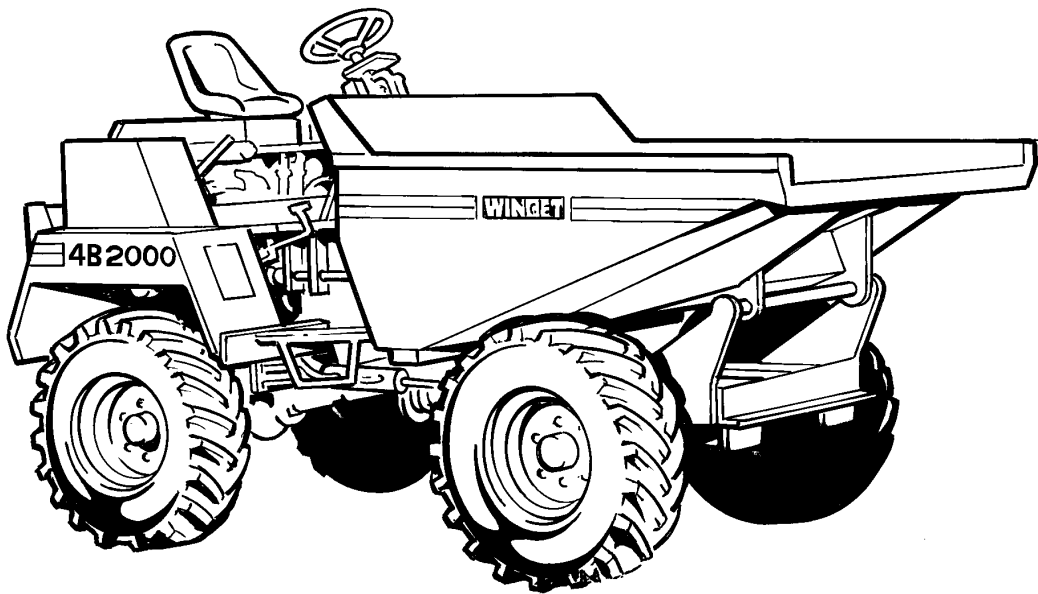

OPERATORS HANDBOOK & PARTS

Manual MANS524

April 2019

WINGET

WINGET LIMITED, P.O. Box 41, Edgefold Industrial Estate, Plodder Lane, Bolton, BL4 0LR, England
Tel: +44 (0) 1204 854650
E mail: parts@winget.co.uk, service@winget.co.uk
www.winget.co.uk

Dumper 4B2000

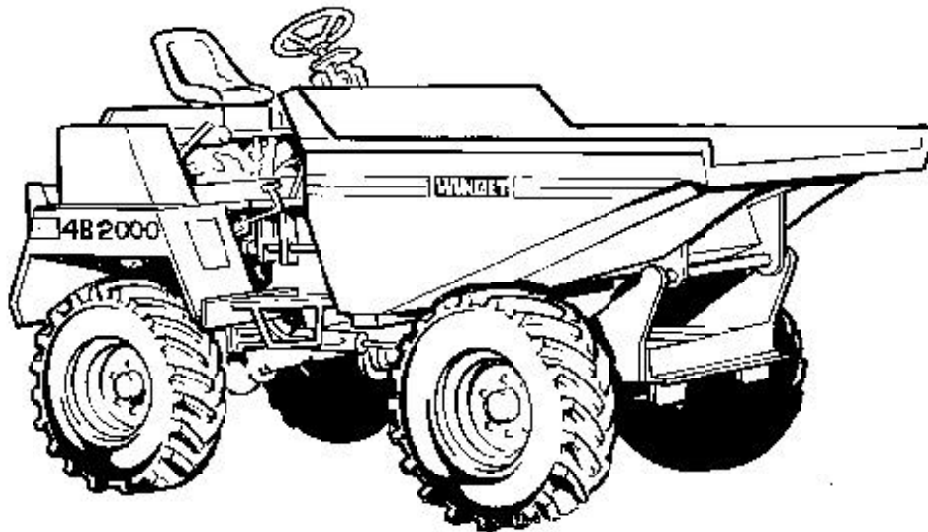

The contents of this Handbook, although correct at the time of publication, may be subject to alteration by the Manufacturers without notice.

Winget Limited operate a policy of continuous product development. Therefore, some illustrations or text within this publication may differ from your machine.

THE HANDBOOK

WARNING The Operator must read all the Handbook and fully understand its contents before attempting to operate the machine.



THE HANDBOOK MUST NOT BE REMOVED FROM THE MACHINE.

The Handbook should be kept clean and in good condition. Additional copies of the Handbook can be obtained from your Distributor.

The contents of this Operators Handbook are designed as a guide to the machine's controls, operation, working capacities and maintenance. It is not a training manual.

Only trained operators should use this machine. Consult your Distributor for details of authorised training courses.

In this Handbook are **WARNING** notes. They are preceded by this symbol:



WARNING *These notes are used to indicate that the procedure being described in the Handbook must be followed to avoid serious injury or death to yourself or others; or damage to the machine.*



The warnings are also used to protect the machine from unsafe servicing practices.

Pay particular attention to the warnings given in the Handbook.

If you have any doubts about any aspect of the machine's capability or servicing procedures, you must consult the manufacturer.

MACHINE IDENTIFICATION

Please record the model and serial numbers of your machine in the spaces provided and quote them when ordering parts.

Model - Year

Front axle

Dumper serial no.

Rear axle

Key, start

Ram steering

Engine

Ram, tipping, L.H.

Gearbox

Ram, tipping, R.H.

Transfer box

Tyre manufacturer & size

WARRANTY TERMS & CONDITIONS

The Manufacturer assures you that if any part of the machine becomes defective due to faulty manufacture or materials within 12 months from the date of purchase, the part will be repaired or replaced under warranty free of charge by any authorised Winget Distributor. Warranty repairs **must** be carried out by Winget Distributors.

This Warranty is given to the first owner and may be transferred to subsequent owners for the balance of the Warranty period.

The Manufacturer's liability only extends to the costs of repair or replacement of the faulty parts and necessary labour charges involved in the repairs. The Company accepts no liability for any consequential loss, damage or injury, resulting directly or indirectly from any defect in the goods.

Items not covered by Warranty and considered to be the customer's responsibility include normal maintenance services; replacement of service items and consumables; replacement required due to abuse, accident, misuse or improper operation; replacement of wearable items e.g. pins, bushes, brake linings, clutch linings etc.

The Warranty will not apply where the equipment is modified, converted, or used for purposes other than those for which it was designed, unless clearance for the modifications etc. have been granted by the Manufacturer, in writing.

The Pre-Delivery Inspection and Warranty Registration Document must be completed correctly and returned to the Manufacturer within 7 days of sale date. Failure to do so may result in the claim being subsequently rejected.

Tyres and tubes are not covered by Warranty, but are covered by the tyre manufacturer's own warranty system which provides against defects in material or workmanship.

Engines are covered separately by the engine manufacturers, and engine warranty repairs must be handled by the relevant engine manufacturers' distributors.

No claim will be considered if other than genuine Winget Limited parts, which must be obtained from Winget Limited via an authorised Distributor, are used to effect a repair, or if lubricants other than those recommended by Winget Limited are used.

The equipment must be serviced in accordance with the service schedules laid down by Winget Limited. Evidence that these have been complied with may be required before Warranty Claims are reimbursed.

The Manufacturer's policy is one of continuous improvement. Winget Limited reserve the right to change specifications without notice. No responsibility will be accepted for discrepancies which may occur between specification of machines and the descriptions contained in publications.

Safety is the responsibility of all persons working with this machine. Think “safety” at all times. ***Read and remember the contents of this handbook.***

The safe working recommendations for specific tasks are found with the instructions for the relevant operation in this Handbook.

MACHINE MODIFICATION

WARNING Any modifications to the machine will affect its working parameters and safety factors. Refer to the Manufacturers before fitting any non-standard equipment or parts.



The Manufacturers accept no responsibility for any modifications made after the machine has left the factory, unless previously agreed by the Manufacturers in writing; the Manufacturers will accept no liability for damage to property, personnel or the machine if failure is brought about due to such modifications, or fitment of spurious parts.

TRAINING

WARNING Only trained operators should use this machine.



Operators should hold an appropriate full motor vehicle driving licence and undergo both a safety awareness course and a driver training course for Site dumpers run by the C.ITB or equivalent body leading to the award of a CTA.

It is strongly recommended that operators read the H.S.E. publication “Safe Working with Small Dumpers” which is available from government bookshops (HMSO) or from other bookshops quoting the following number ISBN O11 8836935. Another useful publication is British Standard number BS 6264, “Procedure for Operator Training For Earth Moving Machinery” available from the British Standard Institution.

RUNNING-IN

WARNING While a gradual ‘running-in’ of a new engine is not necessary, it is extremely important that the instructions given in *Section 1 “Operation”* on “Running-in a new engine” should be followed very closely during the first fifty hours of operation.



DRIVING

WARNING *NEVER* use the machine for purposes other than those for which it was designed. This machine was designed to carry loads such as soil, clay, sand, wet concrete, stone or other similar materials. It was not designed to carry loads which may move around in the skip uncontrollably, nor to carry any loads or materials which overhang the skip in any way. If in any doubt as to the suitability of this machine for a particular task, contact your nearest Distributor or the Manufacturer for advice.



ALWAYS be aware of local and national regulations governing the use of the machine.

NEVER commence work with the machine until the “Daily (or every ten hours)” service checks have been made. (See *Service Section* for details)

ALWAYS check wheel nut tightness daily.

NEVER carry passengers.

Ensure that the seat is securely fixed to the machine. Where seat belt restraints are fitted as part of Rops/Fops protection they must be worn. Check that the seat belt is in good condition, free from cuts and frayed edges.

ALWAYS remain in the driving seat whenever the engine is running. Never attempt to operate any controls unless seated.

ALWAYS apply the parking brake before leaving the driver’s seat.

NEVER dismount with the engine running, and never leave the machine unattended with the key in the starter switch.

When Battery Isolators are fitted they must be activated only when the engine is turned off except in cases of emergency.

Activating a Battery Isolator when the engine is running can result in damage to the electrical components and circuits.

NEVER fill the fuel or hydraulic tanks with the engine running.

ALWAYS drive only on surfaces that are known to be stable.

ALWAYS keep the floor plates and walkways clean.

NEVER drive the machine close to the edge of any excavation. Always use effective wheel stops to prevent the machine running close to the edge. Make sure that the stops are in proportion to the size of the wheels and are set sufficiently far enough back from the edge of any excavation to prevent the weight of the load causing a collapse.

NEVER adjust the tyre pressures in an attempt to improve traction on soft ground or obtain a softer ride on hard ground. Incorrectly adjusted tyres can affect the steering and handling characteristics.

NEVER attempt to free a machine which is ‘bogged down’ by pushing with the bucket of a backhoe loader, tracked excavator or other similar machine.

NEVER make unnecessary “crash stops” when travelling at speed, especially in forward direction.

NEVER work under an unpropped skip. If the skip was supplied with a special skip support always ensure that it is used.

SKIPS AND LOADING

WARNING NEVER exceed the rated payload. The weights of all loads above skip water level must be checked.



NEVER remain on the machine when loading the skip with excavators or loaders. Stop the engine, apply the parking brake, dismount, and stand well clear.

ALWAYS ensure that the load is evenly distributed in the skip.

NEVER carry loads or heap materials in such a manner as to affect the forward vision.

ALWAYS take extra care when tipping non free running loads, particularly with Rotary Skips and High Discharge machines.

NEVER use the skip in a tipped position to bulldoze heaped materials level or to backfill material into excavations.

NEVER leave the machine with the skip raised or rotated.

TOWING

WARNING NEVER attempt to tow a dumper before first reading 'Towing the dumper' (see Contents page).



Dumpers are not designed as towing vehicles, but loads (including weight of trailer) not exceeding the rated payload of the dumper may be towed on dry, level ground in first gear, providing the dumper skip is loaded with half the rated payload to ensure tyre adhesion when braking.

NEVER attempt to start the engine of a dumper by towing or pushing.

ALWAYS use a purpose made towing pin.

NEVER tow loads up, down or across gradients.

GRADIENTS

WARNING NEVER operate on any gradients which exceed 25% (1 in 4), or across gradients which exceed 16% (1 in 6).



ALWAYS remember that slippery or loose surface conditions can adversely affect safe machine operation, including braking, particularly on gradients.

ALWAYS choose routes that avoid steep, slippery or loose gradients.

NEVER coast down gradients. Always negotiate gradients in first gear.

ALWAYS drive forwards up gradients when loaded.

ALWAYS reverse down gradients when loaded.

ALWAYS keep the load facing uphill.

NEVER park on a gradient. If this is unavoidable, ALWAYS chock the wheels.

NEVER attempt to turn on a gradient

NEVER tow up, down or across a gradient.

NEVER operate high discharge or rotating skips on gradients.

HYDRAULICS

WARNING ALWAYS “Dump” residual pressure from the system before leaving the machine or before carrying out any maintenance or adjustments.



If maintenance work requires the skip to be in the raised position, then it must be raised and supported before dumping the pressure.

Dump pressure by switching off the engine, then moving the hydraulic control lever several times in each direction.

NEVER leave the machine unattended with pressure in the system.

ALWAYS purge hydraulic rams before commencing work. With the engine running operate the hydraulic control to fully extend and retract the rams.

ALWAYS practise the greatest cleanliness in maintaining hydraulic components.

SERVICING

WARNING ALWAYS report any defect at once, before an accident or consequential damage can occur.



ALWAYS conform to service schedules except where:

- 1 Warning lights or warning indicators call for immediate attention.
- 2 Adverse conditions necessitate more frequent servicing.

ALWAYS wear correctly fitting protective clothing. Loose or baggy clothing can be extremely dangerous when working on running engines or machinery.

ALWAYS, where possible, work on or close to engines or machinery only when they are stopped. If this is not practical, remember to keep tools, test equipment and all parts of your body well away from the moving parts.

ALWAYS “Dump” pressure from the hydraulic system before carrying out any kind of maintenance or adjustment. (**see Service - Hydraulic system**).

ALWAYS avoid contact with exhaust pipes, exhaust manifolds and silencers when the engine is running; these can be very hot.

ALWAYS work out of doors, or in a well-ventilated area.

NEVER run an engine in an enclosed space. Exhaust fumes in enclosed areas can kill.

ALWAYS disconnect battery cables and remove battery before using an external charger, carrying out welding repairs or to prevent unauthorised usage when unattended or during a repair.

NEVER allow unqualified personnel to attempt to repair, remove or replace any part of the machine, or anyone to remove large or heavy components without adequate lifting tackle.

NEVER attempt to modify or repair Rops Frames or Fops Canopies by welding, drilling or any other means. Attempts to do so will invalidate Rops/Fops Certification.

ALWAYS obtain advice before mixing oils; some are incompatible. If in doubt drain and refill.

NEVER allow oils and fuels to come into regular contact with skin. This can lead to serious skin diseases including, medical evidence suggests, skin cancer. *ALWAYS* wear protective gloves when handling oils and fuels whether topping up, draining or refilling. *ALWAYS* wash hands if oils or fuels come into contact with the skin.

Many liquids used in this machine are harmful if taken internally or splashed into the eyes. In the event of accidentally swallowing oils, fuels, anti-freeze, battery acid etc, *DO NOT* encourage vomiting, seek qualified medical assistance immediately.

ALWAYS dispose of waste oils and fuels into waste oil storage tanks. If storage tanks are not available consult your distributor or local authority for addresses of local designated disposal points. It is illegal to dispose of waste oil into drains or water courses or to bury it.

Equipment which includes friction materials will sometimes contain asbestos. When removing friction material dust from components, such as when servicing brakes or clutches, do not blow out with an airline; it could be harmful to inhale the dust. Remove the dust with a vacuum cleaner or wipe clean with a damp rag. Waste should be placed in a sealed container, marked, and disposed of in accordance with local or national regulations.

The accumulated dust found in clutch housings may contain lead/antimony. No food should be eaten at a work place contaminated by this dust. Hands must be washed before eating. Do not blow out dust with an airline.

NEVER work under an unpropped skip. ***If the skip was supplied with a special skip support always ensure that it is used.***

ALWAYS ensure that when using a starting handle that it is clean and in good condition. Keep the engine starting dog and the part of the starting handle that mates with it lightly lubricated (*Refer to the Engine Handbook*).

DECALS

Attached to the dumper are several pictorial warning decals

Ensure that all decals fitted to the dumper are legible. If any should become detached, they must be replaced immediately

For detailed information on how to safely use the items described by the decals, see the "Safe working, Operation and Servicing" sections of this Handbook.

Descriptions of the decals are as follows:

Fuel tank filling point.



Wear ear protection.



Hydraulic oil filling point.



The Battery Isolator is situated close to this decal.



Remove starting handle.

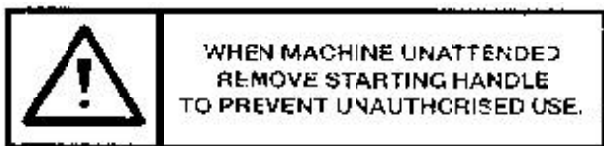

Read Operators Handbook, or Operators Handbook storage place.

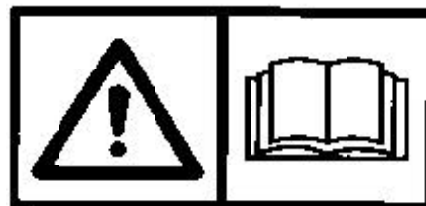

Attach lifting hooks to this eye.

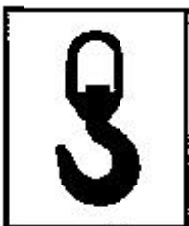

The battery negative terminal is connected to earth.



CE (EC machines only)



Beware of electrical hazards



Always reverse down gradients when loaded



These surfaces may be hot.



Forks and buckets are not to be used to push or lift the dumper.



The figures shown on these decals are the maximum loads for the skips onto which the decals are fastened.



Keep hands away from moving parts.



ISO Skip Support, when used, is pinned around the tipping ram rod to prevent the ram from closing.



Always wear eye protection.



Stand clear of the articulation area of the dumper



ISO 8999 safety symbols used with Lister-Petter engines



Read the handbook



Stop control (on engine)



Diesel fuel fill



Engine oil fill



Engine oil level



Engine oil pressure



Anti-clockwise rotation



Clockwise rotation



Lifting eye (engine only)



On

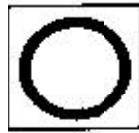

Off

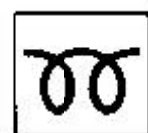

Pre-heat



Rotational speed control



Linear speed control



Tachometer



Elapsed hours

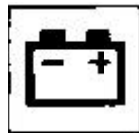

Battery Charging



Engine cranking



General hot surface warning



Electrical hazards

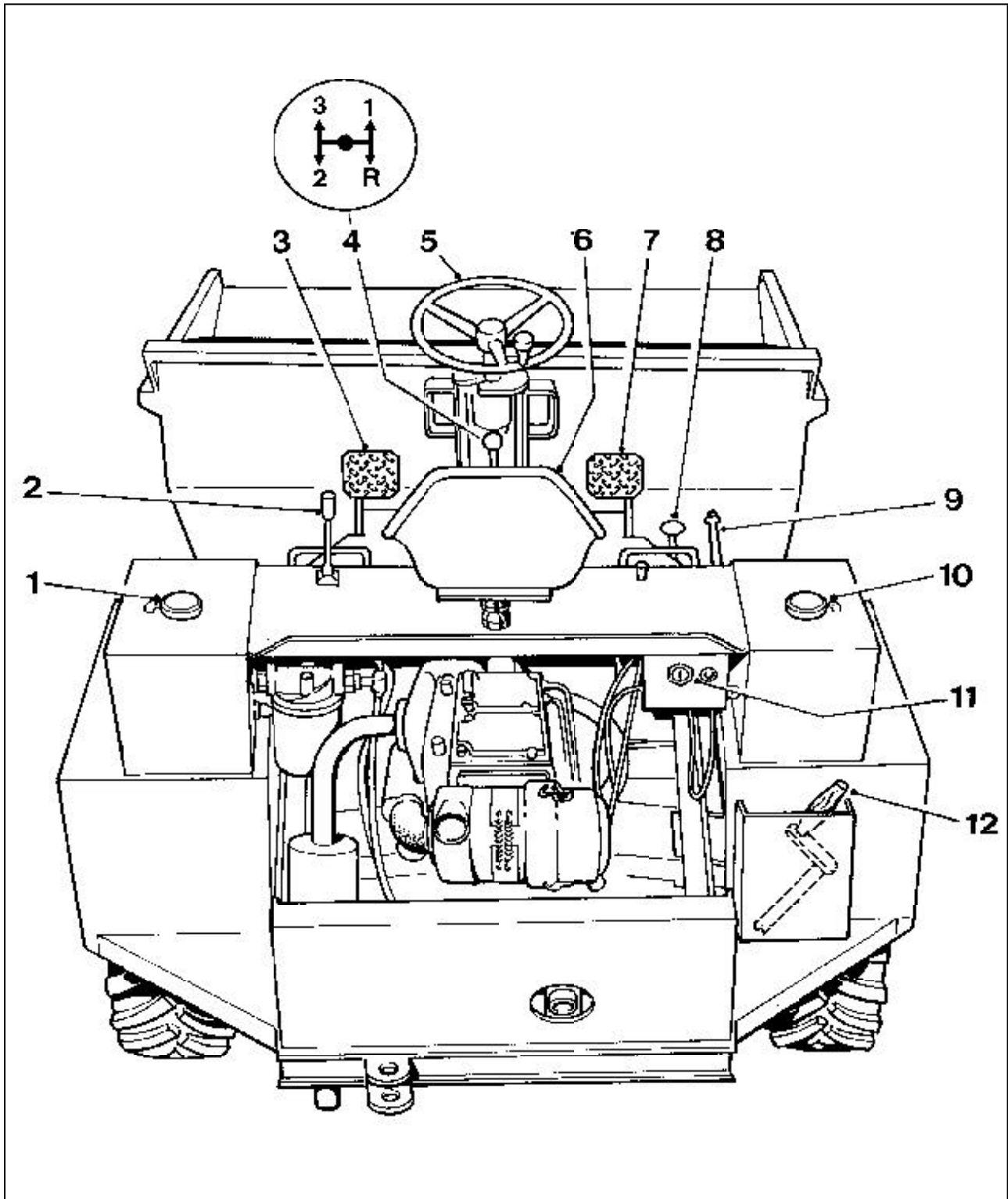

- 1 Hydraulic oil filler cap
- 2 Skip control, tip/return
- 3 Clutch
- 4 Gear lever
- 5 Steering wheel
- 6 Seat

- 7 Foot Brake
- 8 Accelerator
- 9 Parking brake
- 10 Fuel filler cap
- 11 Key start switch (where fitted)
- 12 Engine starting handle (stowage)

ROAD LIGHTS SWITCH PANEL

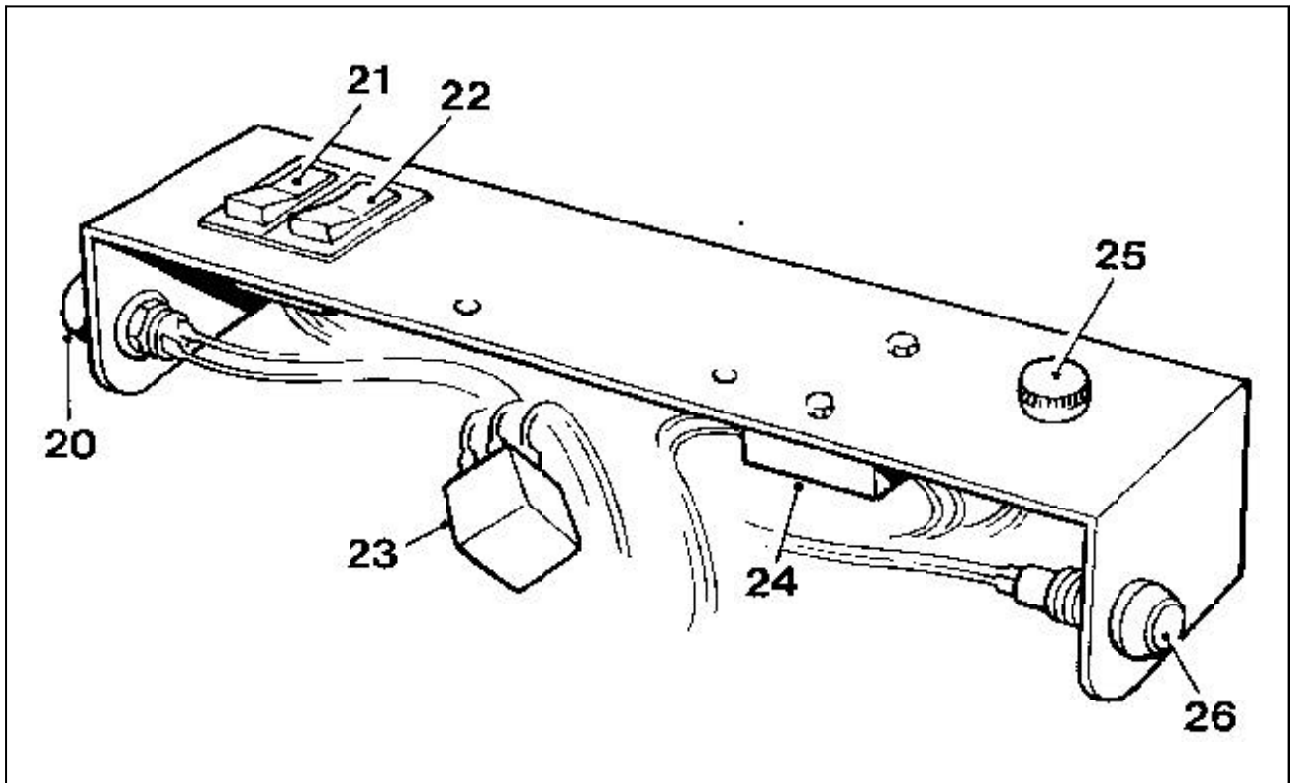

20 Horn

21 Switch: Side and head lights

22 Switch: Hazard warning lights

23 Flasher unit

24 Fuse box

25 Switch: Direction indicators

26 Warning light: Direction indicators

Safety warnings

Read also the “*Safe Working*” Section before operating the dumper.

WARNING ALWAYS wear correctly fitting



protective clothing. Loose or baggy clothing can be extremely dangerous when operating or servicing machinery.

Only skilled personnel are permitted to work with this machine.

ALWAYS be aware of local and national regulations governing the use of this machine.

Starting the engine

WARNING NEVER use ether type starting aids.



ALWAYS stop the engine if the battery charge warning light (where fitted) fails to cancel.

ALWAYS stop the engine if warning lights illuminate. Detect the fault before continuing.

DO NOT PROCEED IF A FAULT IS EVIDENT

NEVER attempt to start the dumper by pushing or towing.

NEVER operate controls unless you are seated on the machine, and ALWAYS remain in the driving seat whenever the engine is running.

Running-in a new engine

While a gradual ‘running-in’ of a new engine is not necessary, it is EXTREMELY IMPORTANT that the following instructions should be followed very closely during the first fifty hours of operation.

- 1 Avoid overloading the engine.
- 2 Use the lower gears when operating with heavy loads, and avoid continuous operation at constant engine speeds.
- 3 Check the instruments frequently, and keep the oil compartments and the hydraulic reservoirs filled to their recommended levels.
- 4 Do not operate the engine at high speeds without a load.
- 5 Do not allow the engine to run at idle speeds for long periods; this may cause bore glazing and an increase in oil consumption.

Operating in this way throughout the machine’s life will prove beneficial to its overall performance and efficiency.

Pre-start Checks

WARNING NEVER commence work with the machine until the checks detailed in “Every 10 operating hours, or daily” have been carried out. (See *Service Schedule*).



Check that all controls are clean and not slippery, and that they all function correctly.

Check that the areas around pivot points, rams and linkages are all free from mud, ice and debris.

Check that all grab handles, steps and platforms are clean and dry.

Check the machine for any obvious damage or faults.

Check that all decals can be clearly read.

DRIVING THE DUMPER

Petter PH2 engines (UP TO 1988)

To start Petter PH2 engines:

Ensure the parking brake is in the raised "ON" position.

Ensure gear lever is in the neutral position.

WARNING *If a starting handle is to be used, see that the shaft is greased. Make sure the starting handle can be freely withdrawn.*



On the engine, lift the overload stop (A) and move the fuel pump rack (D) in the direction of the arrow to the fully open position.

Operate the fuel pump priming lever (C) approximately six times. (This is unnecessary with a warm engine.)

Lift the decompression lever (B) to the vertical position. Crank the engine as fast as possible or use the starter motor. When the engine is turning at a good speed, knock down the lever (B). The engine should now fire.

If the engine does not fire, lift the decompressor lever (B) and slowly turn the engine a few times before attempting to start again. Do not operate the starter motor for more than 20 seconds at a time.

Note: If it is necessary to bleed and prime the fuel system, consult the *PH2 Engine Operators Handbook*.

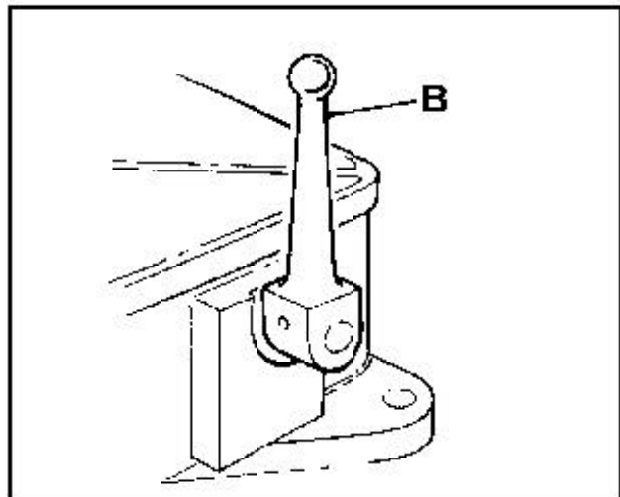
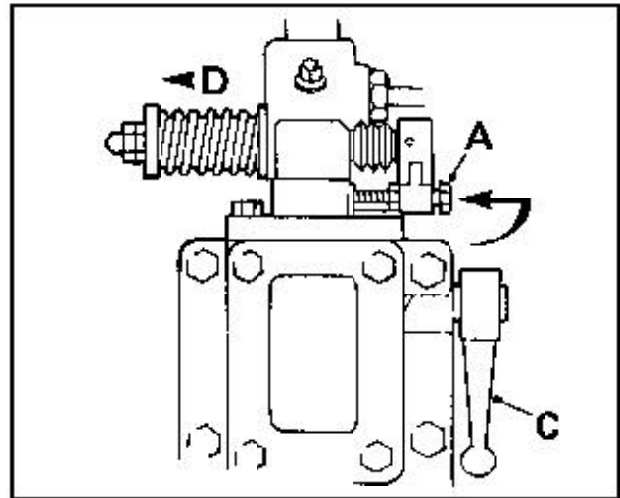

To stop PH2 engines:

WARNING *NEVER stop the engine by using the decompressor lever. This will lead to damaged valve seats and cylinder head joints.*



DO NOT stop the engine by allowing the tank to run dry. This will make it necessary to bleed and prime the system.

DO NOT remove or alter the setting of the overload stop.

It is advisable to run on light load for a few minutes before stopping.

Raise the priming lever (C) to the vertical position, or move and hold the fuel pump rack (D) away from the fly wheel until the engine stops.

Lister ST2 engines (UP TO 1988)

To hand start Lister ST2 engines:

Ensure the parking brake is in the raised "ON" position.

Ensure gear lever is in the neutral position.

Move the decompressor lever over towards the flywheel (F).

Pull the control lever outwards and allow it to rotate anticlockwise so that it abuts against the top stop and is in a vertical position (G).

IMPORTANT: *Ensure that the starting handle is of the correct type and is fully servicable. Lightly oil the end of the starting shaft and the starting handle.*

Check the arrow on the handle for correct rotation, then turn the handle in the opposite direction to that required to start engine. This is done in order to check that the clutch pin will disengage from the keyway, and does not bind on the starting shaft.

ENSURE THERE ARE NO BURRS ON THE SHAFT.

IMPORTANT: *With the starting handle, turn the engine slowly from 3 to 20 turns according to the temperature and period of standing unused, in order to prime the combustion chamber and the lubricating oil system.*

Turning the starting handle in the correct rotation, crank the engine really fast and when maximum cranking speed is reached move the decompressor lever away from the flywheel (H). Retain a firm grip on the starting handle and continue to crank until the engine fires. Remove the starting handle from the shaft.

WARNING *It is dangerous to allow the handle to rotate on the running shaft.*

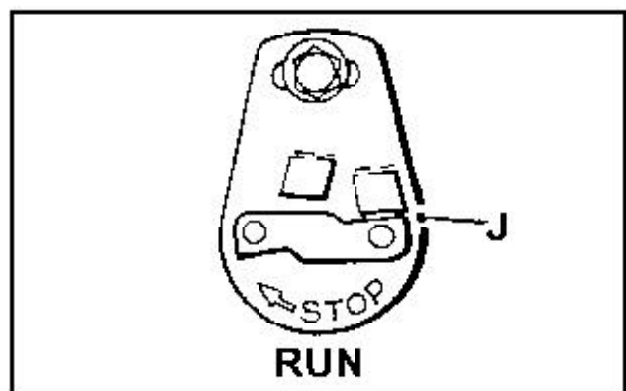
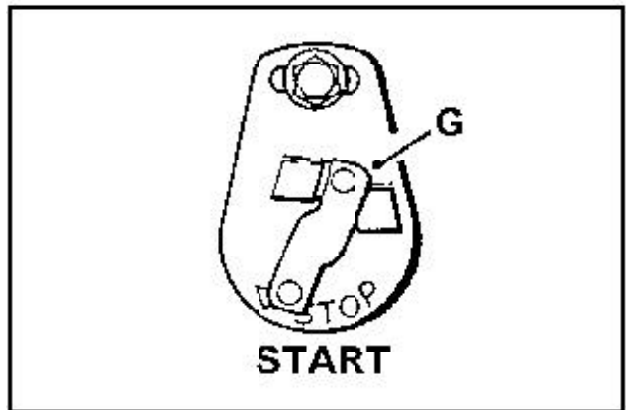
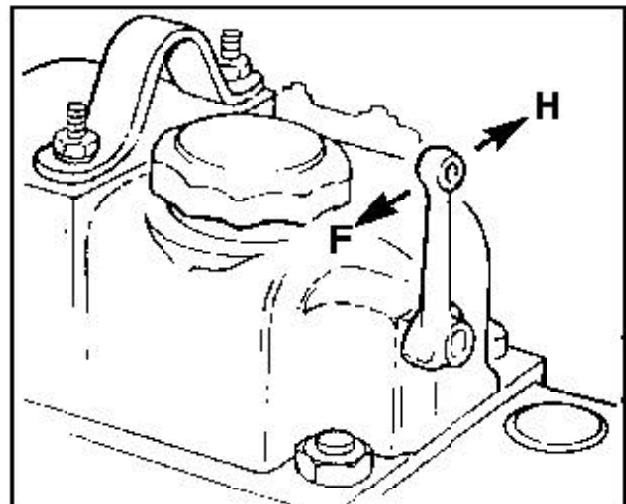

IMPORTANT: *As soon as the engine reaches normal speed, turn the control lever clockwise to the horizontal position so that it abuts the horizontal stop (J).*

DRIVING THE DUMPER

To key (Electric) start Lister ST2 engines:

Ensure the parking brake is in the raised "ON" position.

Ensure gear lever is in the neutral position.

Depress and hold down the accelerator.

Pull the control lever outwards and allow it to rotate anticlockwise so that it abuts against the top stop and is in a vertical position (G).

Turn the starter key and release immediately the engine fires. Do not motor the engine continuously for more than 20 seconds.

Release the accelerator pedal.

IMPORTANT: As soon as the engine reaches normal speed, turn the control lever clockwise to the horizontal position so that it abuts the horizontal stop (J).

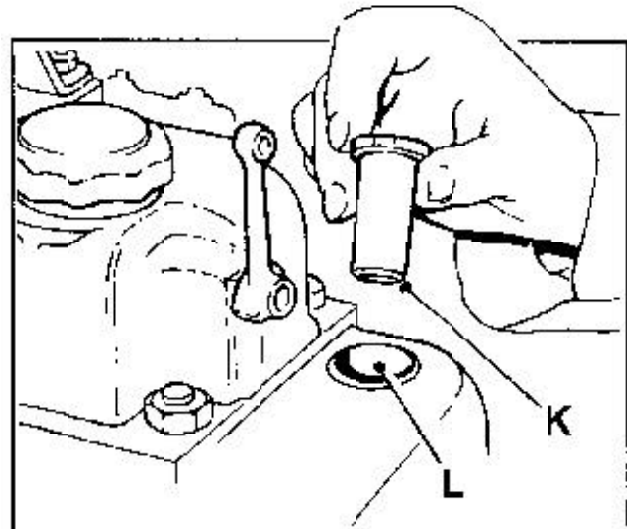
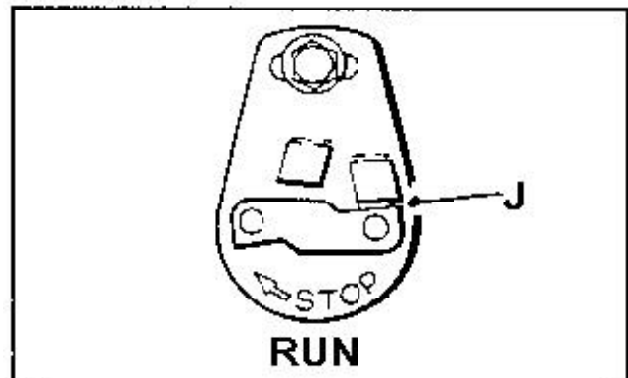
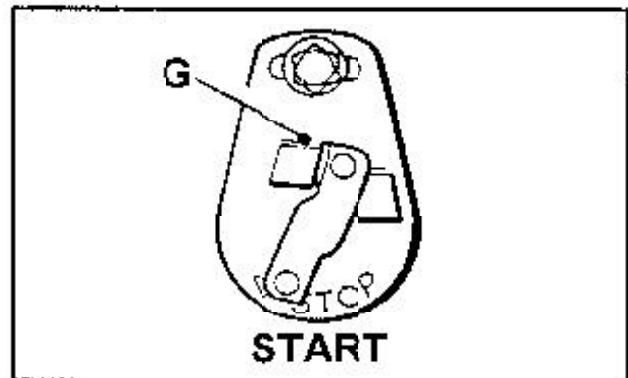

Cold Starting Below -10°C (14°F)

A cup and plunger is fitted to the combustion air intake port on ST engines. Operate as follows:

Withdraw the plunger (K) and fill one third of the cup (L) with the same type of lubricating oil as used in the engine.

Replace the plunger and inject the oil just before starting the engine.

The device must not be used more than three times in succession. When hand starting, turn the engine 20 revolutions with the fuel on after injecting the oil, before attempting to start.

To stop engine

Turn the control lever clockwise in the direction of the arrow (M) and hold it until the engine stops.

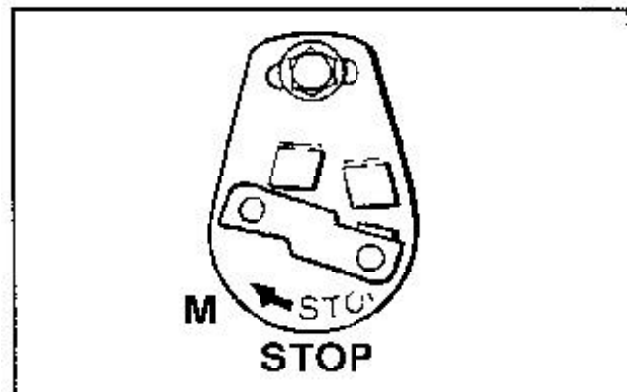

TS/TR2 engines

Description

- A Dipstick
- B Lubricating oil filler
- C Engine control
- D Decompressor levers
- F Cold start oil cup
- G Fuel lift pump

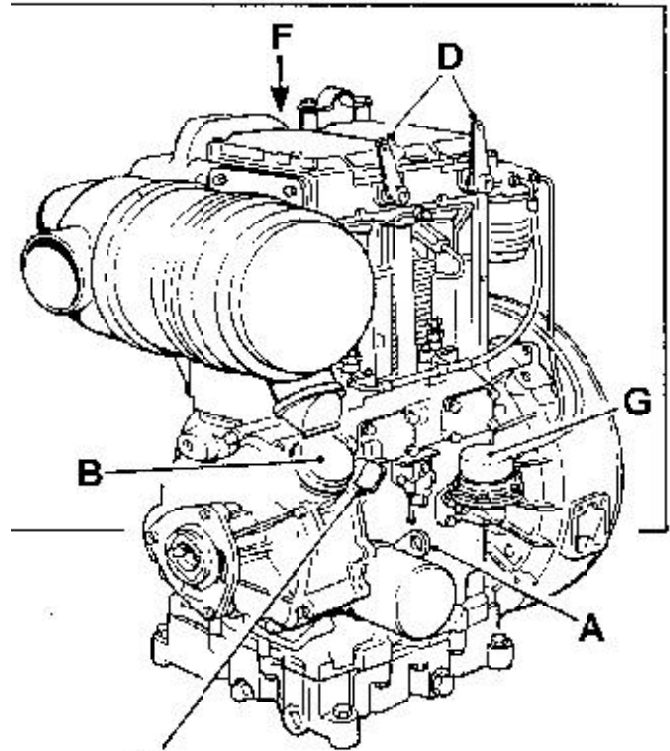

Automatic Excess Fuel Device

The engine is fitted with an automatic excess fuel device which becomes operative, ready for the next start, when the engine is stopped.

If the engine stops other than by the operation of the engine control, the control (C) must be turned anti-clockwise to the 'STOP' position and released before the device can operate.

As the engine runs up to speed the excess fuel device will automatically reset to the normal running position.

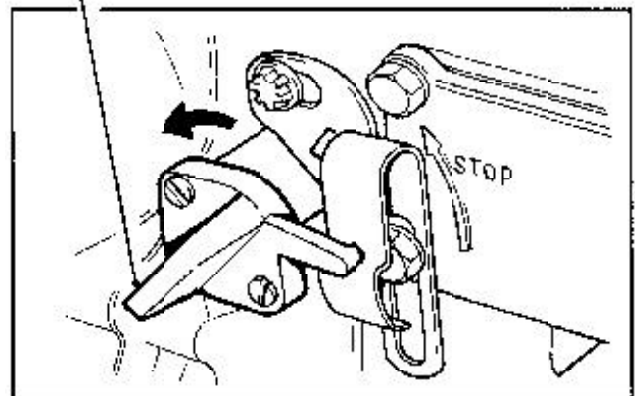

Cold Starting Below -10°C (14°F)

A cup and plunger is normally fitted to the combustion air intake port on TR and TS engines.

With the fuel turned on, turn the engine for up to 20 revolutions to prime the fuel and lubrication systems.

Withdraw the plunger (H) and fill one third of the cup (J) with the same type of lubricating oil as used in the engine.

Replace the plunger and inject the oil just before starting the engine.

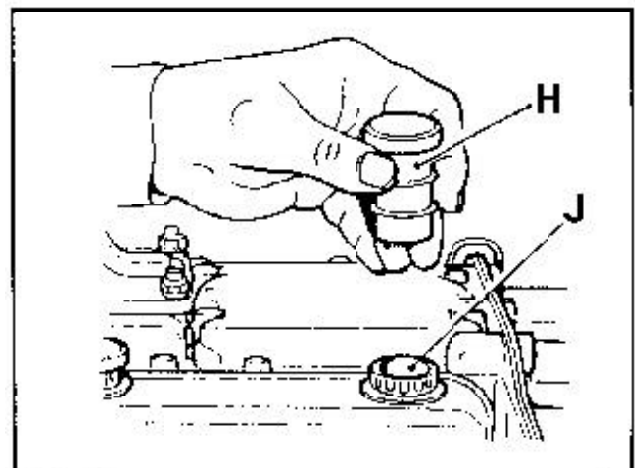

WARNING *The device must not be used more than three times in succession during the same attempt to start the engine.*



DRIVING THE DUMPER

Hand starting TS/TR2 engines

Ensure the parking brake is in the raised “ON” position.

Ensure gear lever is in the neutral position.

Always use the correct starting handle which has been designed for the engine.

Ensure there are no burrs on the handle.

Before attempting to use the handle, clean and lightly oil that part of it which fits onto the engine.

WARNING *Do not attempt to use a handle if it is damaged in any way.*



Turn the engine control lever anti-clockwise to the “STOP” position (**L**) and release it.

Move the decompressor lever towards the flywheel (**M**).

Insert the correct handle into the starting housing.

Turn the engine slowly for up to 20 turns to prime the combustion chamber and lubricating oil system.

Maintaining a firm grip on the starting handle, crank the engine really fast and when sufficient speed is obtained move the decompressor lever away from the fly wheel (**N**) and continue to crank until the engine fires.

Retain a firm grip on the handle and remove it from the engine.

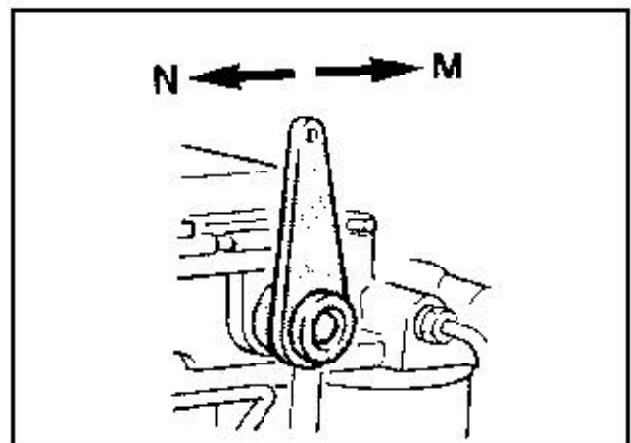
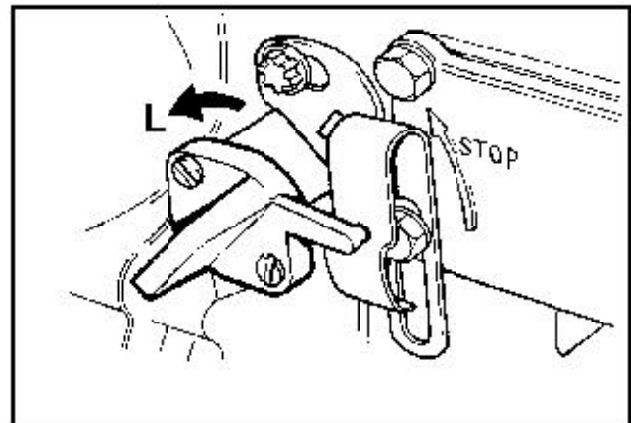

Key Starting TS/TR2 engines

Ensure the parking brake is in the raised "ON" position.

Ensure the gear lever is in the neutral position.

Fully depress and hold down both clutch and accelerator pedals.

Check that the decompressor lever, (if fitted) is away (**N**) from the flywheel.

Turn the engine control lever anti-clockwise to the "STOP" position (**L**) and release it.

Turn the start key clockwise to position (**1**), the battery charging light (**P**) will illuminate.

Turn the key and hold at the "START" position (**2**) until the engine fires and then release it immediately.

If the engine fails to start within 20 seconds, release the key and attempt to restart after allowing sufficient time for all moving parts to stop.

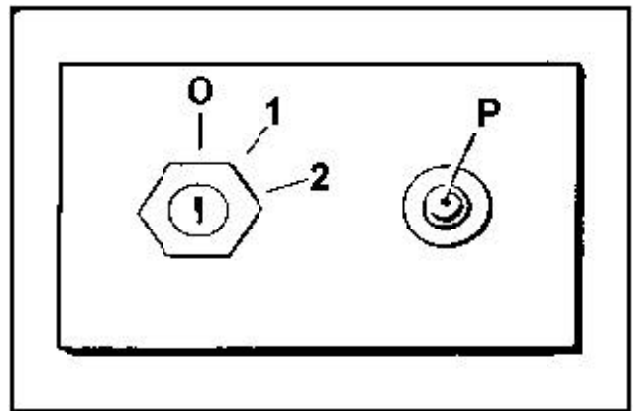
**Stopping the engine**

WARNING Never stop the engine by operating the decompressor lever or valve damage may occur



Key start engines: Turning the starter key to the "OFF" (**0**) position will not stop the engine.

It is advisable to run on light load for a few minutes before stopping.

Turn the engine control anti-clockwise to the "STOP" position (**L**) and hold it there until the engine comes to rest.

Key start engines: After the engine has stopped, turn the starter key to the "OFF" (**0**) position.

DRIVING THE DUMPER

Gradients

IMPORTANT: *Read the notes in “Safe Working” and also remember the following:*

Slippery or loose surface conditions can adversely affect safe machine operation, particularly on gradients.

ALWAYS choose routes that avoid steep, slippery or loose gradients.

NEVER park the machine on a gradient.

NEVER attempt to turn on, or drive across, a gradient.

ALWAYS drive forwards up gradients when loaded.

ALWAYS reverse down gradients when loaded.

NEVER tow up or down gradients.

NEVER operate on a gradient which exceeds 25% (1 in 4), or across gradients which exceed 16% (1 in 6). This should be reduced where surfaces are wet or unstable.

NEVER operate high discharge or rotating skip options on gradients.

Braking

Dumpers with hydraulically operated brakes

The brake pedal operates a hydraulic master cylinder that supplies oil to brakes within the front axle. (Brakes fitted within the rear axle are an option.)

The handbrake operates a caliper that acts upon a disc mounted on the transmission.

Engaging gear lever

When changing gear, always depress the clutch pedal before moving the gear lever from one gear to another.

Stopping the dumper

IMPORTANT: Never make unnecessary ‘crash’ stops when travelling at speed, especially in forward direction.

Release accelerator and brake to a halt progressively.

Select neutral gear.

Apply parking brake when stationary.

Stop the engine. Turn the starter key to the ‘OFF’ position, and remove the key.

Leaving the dumper

Ensure the machine is parked on firm, level ground. Do not park on a gradient.

Check that the parking brake is applied.

Ensure that the skip is fully lowered.

With the engine stopped, operate the skip hydraulic control lever fully in each direction several times to ‘dump’ hydraulic pressure from the system.

Remove starter key (where fitted) from switch.

Electric start dumpers: If unattended for some time, remove earth cable from battery, or activate the Battery Isolator, (where fitted).

Skip operation

Loading

Never remain on the dumper when using excavators or loaders to load the skip. Stop the engine, apply the parking brake, dismount, and stand well clear.

Ensure that the load is evenly distributed in the skip. Never carry loads in such a manner as to affect the forward vision.

Never exceed the rated payload. The weights of all loads above skip water level must be checked.

Tipping

Only discharge on level ground.

It is recommended that only free flowing materials be tipped. *Take extra care when tipping non free running loads.*

Skip control lever

The control lever has three positions; they are, Tip (or Dump), Hold and Return.

To tip the skip:

Move the lever to DUMP.

To return the skip:

Move the lever to RETURN.

If the lever is released when in the DUMP or RETURN position, it will automatically return to the central HOLD position and movement of the skip will stop. In this way, the speed at which the skip is tipped can be finely controlled.

However, if the skip is raised and the engine is switched off, DO NOT operate the control lever as the skip will rapidly lower to the chassis

Rotating skip (manual rotation)

After releasing the turntable locking catch, rotate the skip manually, then tip by using the hydraulic control lever.

When returned to the carrying position, ensure that the turntable catch is locked.

Rotating skip (hydraulic rotation)

The skip is operated by a joystick control valve; the lever of which is moved through a gate.

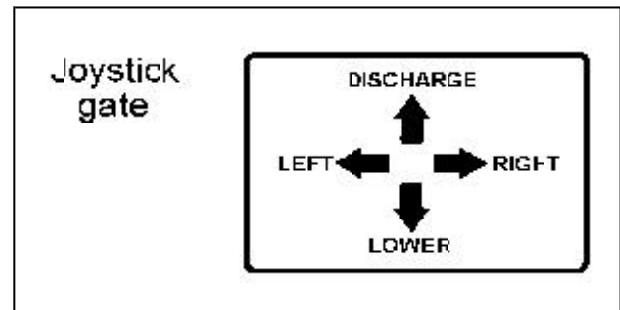

Because of the gate it is not possible to move the lever diagonally, therefore it is not possible to tip and slew the skip simultaneously.

WARNING *Before attempting to slew the skip; the dumper must be stationary, on level ground, with the front and rear chassis in-line (not articulated) and with the parking brake applied*



When the skip is fully lowered, the rear of the skip locates into a recess in the chassis. This is to ensure that there is no rotary movement of the skip while the dumper is travelling.

To slew the skip:

Look at the rear of the skip where it is recessed into the chassis.

With the joystick lever, gently tip the skip forward just sufficiently to raise the rear of the skip clear of the recess. Allow the lever to "self-centre".

Move the lever in the direction that you wish to turn the skip.

Allow the lever to "self-centre".

Move the lever forwards to tip the skip.

Reverse the procedure to return the skip to the travelling position.

WARNING *Be sure that the rear of the skip has fully seated in its recess in the chassis before travelling.*



DRIVING THE DUMPER

Towing with the dumper

Dumpers are not designed as towing vehicles, however, trailers may be towed providing that:

- 1 The combined weight of the trailer and its load does not exceed the specified maximum dumper payload.
(see "specifications")
- 2 Trailers may be towed in first gear on level dry ground, provided a purpose made towing pin is used.
- 3 The dumper skip must be loaded with half the rated payload to ensure tyre adhesion when braking.

Never tow loads up, down or across gradients.

Towing the dumper

The dumper should only be towed if recovery is needed of a broken-down unit, or to free a "bogged down" machine.

Always ensure that ropes, chains, etc. used to tow the dumper have sufficient safe working load capability.

When towing the dumper, always ensure that the speed is kept to an absolute minimum.

Always tow the dumper with the gear lever in neutral.

Never attempt to start the dumper by pushing or towing.

WARNING *Read the safety notes in “Safe Working”, Section 1 of this book.*



Also note the following:

Safe handling of oils, filters and filter elements

WARNING *Do not allow oils to come into regular contact with skin. This can lead to serious skin diseases. Medical evidence suggests they may include skin cancer.*



Always wear protective gloves when handling oils for topping up, draining, or refilling.

Dispose of waste oil into waste oil storage tanks. If storage tanks are not available, consult your Distributor or local authority for addresses of local designated disposal points.

It is illegal to dispose of waste oil into drains or water courses or to bury it.

The materials used in the manufacture and treatment of some filters and elements may cause irritation or discomfort if they come into contact with the eyes or mouth and they may give off toxic gases if they are burnt.

After handling any filters or oils the user's hands should be thoroughly washed, particularly before eating.

Used filter elements contain some of the filtered oil and should be handled and disposed of with care.

SERVICE SCHEDULE

IMPORTANT: The engine will require additional services or adjustments in addition to those listed below (See the appropriate Engine Operator's handbook or Workshop Manual).

WARNING *Warning lights and indicators
REQUIRE IMMEDIATE ACTION.*



<i>SERVICE OPERATION</i>	<i>REFERENCE</i>	<i>PAGE</i>
--------------------------	------------------	-------------

Every 10 operating hours, or daily, the above and the following

Engine oil level	Engine	3.4
Fuel tank level	Engine	3.6
Air cleaner	Engine	3.9
Wheel nut tightness	Wheels & tyres	3.22
Axle oil seals	Axles	3.23
Hydraulic oil level & hose condition	Hydraulic system	3.16

Every 50 operating hours, or weekly, the above and the following

Axle nuts	Axles	3.23
Axle oil levels	Axles	3.23
Tyre pressures & condition	Wheels & tyres	3.22
Fuel tank filler strainer	Engine	3.6
Battery electrolyte level	Battery	3.13
Grease nipples	Greasing	3.19
Gearbox / Transfer box oil levels	Gearbox / Transfer box	3.10
Parking brake Check function of the parking brake and adjust if necessary.		
Propeller shaft Tighten securing nuts. (See also <i>Propeller Shaft Installation</i> on page 3.12)		
Brake pedal travel Check the action of the brake pedal; it should have a short travel and firm action. If travel is excessive, or the action spongy, have the brakes serviced by your distributor.		

First 100 operating hours

Hydraulic oil filter	Hydraulic system	3.17
----------------------	------------------	------

<i>SERVICE OPERATION</i>	<i>REFERENCE</i>	<i>PAGE</i>
--------------------------	------------------	-------------

Every 125 operating hours, the above and the following

Air cleaner element	Engine	3.9
---------------------	--------	-----

Every 250 operating hours, the above and the following

Engine oil and filter	Engine	3.5
Fuel filter	Engine	3.7

Every 300 operating hours, the above and the following

Hydraulic oil filter	Hydraulic system	3.17
----------------------	------------------	------

Every 500 operating hours, the above and the following

Air cleaner element	Engine	3.9
Fuel filter	Engine	3.7
Frame assembly bolts	Check all structural nuts & bolts for tightness.	

Every 1000 operating hours, the above and the following

Hydraulic oil & filter	Hydraulic system	3.17
Gearbox / Transfer box oil change	Gearbox / Transfer box	3.10
Axle oil change	Axles	3.23

Every 2000 operating hours, or 2 years, the above and the following

Brake system overhaul	Braking system	3.20
-----------------------	----------------	------

Extra services

Dirty working conditions

Increase the frequency of all services during extremes of dirt, heat and cold, especially those relating to clean air, cooling efficiency, lubrication and machine cleanliness.

Laying-up protection

When a machine is to remain idle, remove the battery to the workshop. Seal all openings: air intake, exhaust breathers. Grease bright parts and protect rubber components from direct sunlight. Fill the fuel tank, check the tyre pressures and exhaust any pressure from the hydraulic system.

ENGINE**Engines fitted in dumpers**

Up to 1985: Lister ST2 and Petter PH2

1985 to 1989: Lister-Petter PH2

1985 to 1989: Lister-Petter TS2

Note: from 1989 the TS2 has been offered as an option

1989 to date: Lister-Petter TR2

IMPORTANT

To service the following engines,

**Lister ST2
Petter PH2**

Please refer to relevant Engine Operator's Handbook or Workshop Manual.

Lister-Petter TS/TR2

These engines will require additional services and adjustments in addition to those quoted in this handbook. Please refer also to the relevant Engine Operator's Handbook or Workshop Manual.

Engine lubrication oil

For engine oil grades and oil change periods when operating in temperatures above 30°C, see "Engine Handbook".

WARNING *Lubrication oil cleanliness is vital for the successful operation of your engine. The oil should be stored under the cleanest possible conditions. When changing or topping-up oil, use only clean receptacles.*



Always wear protective gloves when handling oils for topping up, draining, or refilling.

Oils and fuels can cause skin irritation. Wear suitable protective clothing to prevent skin contact.

After handling oils the users hands should be thoroughly washed, particularly before eating.

Every 10 operating hours, or daily

Engine oil level

Check lubrication oil level as follows:

Stop the engine and allow the oil to settle.

Remove and clean the dipstick (B), then check that the oil is at the full mark. If the level is low, top up through the filler (C) to the full mark with clean oil of the correct grade. DO NOT OVERFILL.

For correct grade of engine oil, see "Specifications".

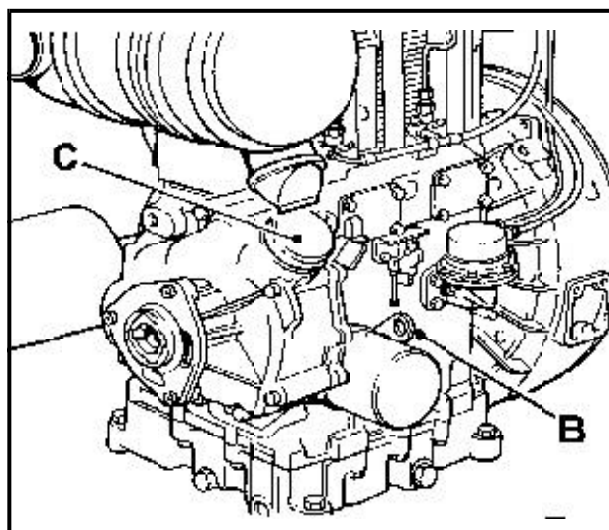

Every 250 hours**Engine oil**

Drain and refill the oil sump as follows:

If possible run the engine immediately before draining the oil.

Place a suitable container under the drain plug. Remove the drain plug (D) and drain oil.

Clean and coat the threads of the drain plug with an appropriate sealant.

Replace the drain plug (D) taking care not to overtighten it.

Fill the sump through the oil filler (C) to the top mark on the dipstick (B).

Start the engine, run it for a few minutes and check the drain plug does not leak.

Stop the engine, allow the oil to settle and check the level on the dipstick.

Add more oil if necessary.

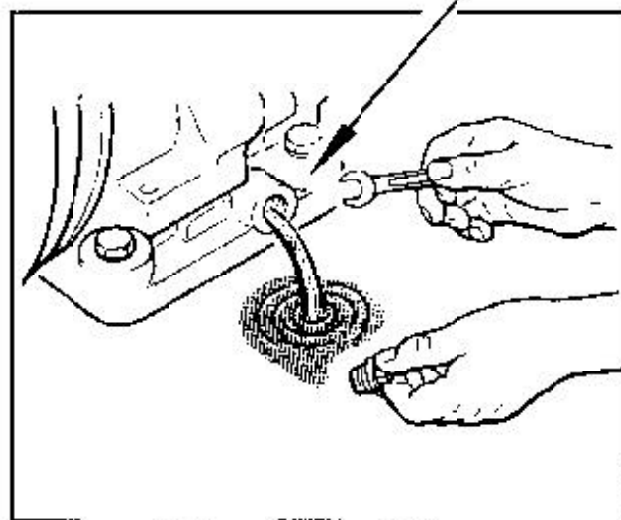
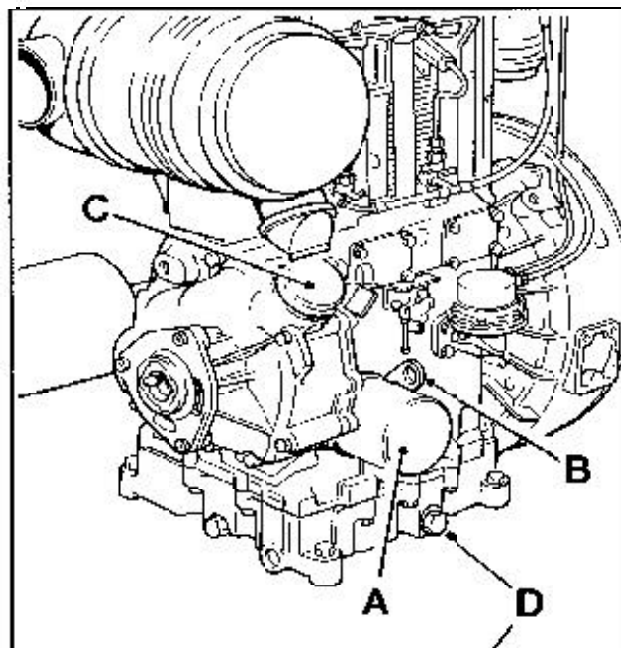
**Every 250 hours****Oil filter**

Change oil filter element as follows:

Using a suitable strap wrench, unscrew and remove the old filter (A).

Do not attempt to clean the old filter! Dispose of it safely.

Thoroughly clean the crankcase filter housing face.

Apply a small amount of clean engine oil to the filter sealing joint.

Do not use a strap wrench to fit the new element.

Screw on the new filter by hand, until the sealing joint is just touching the crankcase and then tighten a further half turn.

Run the engine and check for any oil leaks.

Stop the engine, allow the oil to settle and check the level on the dipstick (B).

Add more oil if necessary.

Do not check oil level until the engine has been stopped for 2 minutes.

Remove and clean dipstick then check that the oil is at the full mark. If level is low, top up through the filler to the full mark with clean oil of the correct grade. DO NOT OVERFILL.

For correct grade of engine oil, see "Specifications".

ENGINE

Every 10 operating hours, or daily

Fuel tank

Fill the fuel tank at the end of each day to reduce overnight condensation within the tank.



WARNING *Never mix gasoline or any other fuel mixes with diesel fuel because of increased fire or explosion risks.*

Never remove the filler cap, or refuel, with the engine running.

Never smoke when refilling the tank.

To fill the tank:

Stop the engine.

Clean the area around the filler cap.

Remove the cap.

Fill the tank. *Do not fill the tank to capacity. Allow room for expansion, and wipe up spilt fuel immediately, otherwise paintwork will be damaged.*

Replace cap.

**Fuel filter
(Cartridge Agglomerator)**

Check that there is no accumulation of water in the base of the agglomerator by unscrewing the drain tap (L) sufficiently to allow any water to empty, then retighten the tap.

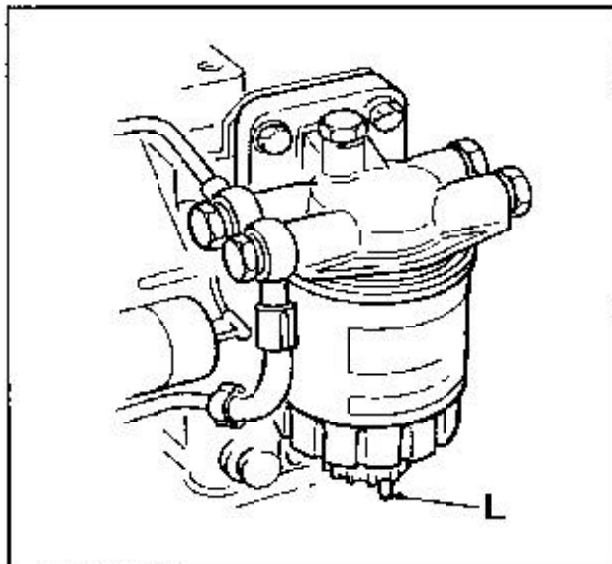

Every 50 hours

Fuel tank strainer

When filling the fuel tank, check that the strainer within the filler neck is clear of sediment.

Every 250 hours

Fuel filter element/cartridge

Change the fuel filter element/cartridge if the fuel being used is not perfectly clean (see below).

Every 500 hours

Filter Element, or Cartridge Agglomerator

Change Fuel Filter Element as follows:

- Remove the retaining bolt (E).
- Remove the element (F) and joints (G).
- Fit new element and new joints.
- Replace and tighten retaining bolt (E).
- Prime the system.

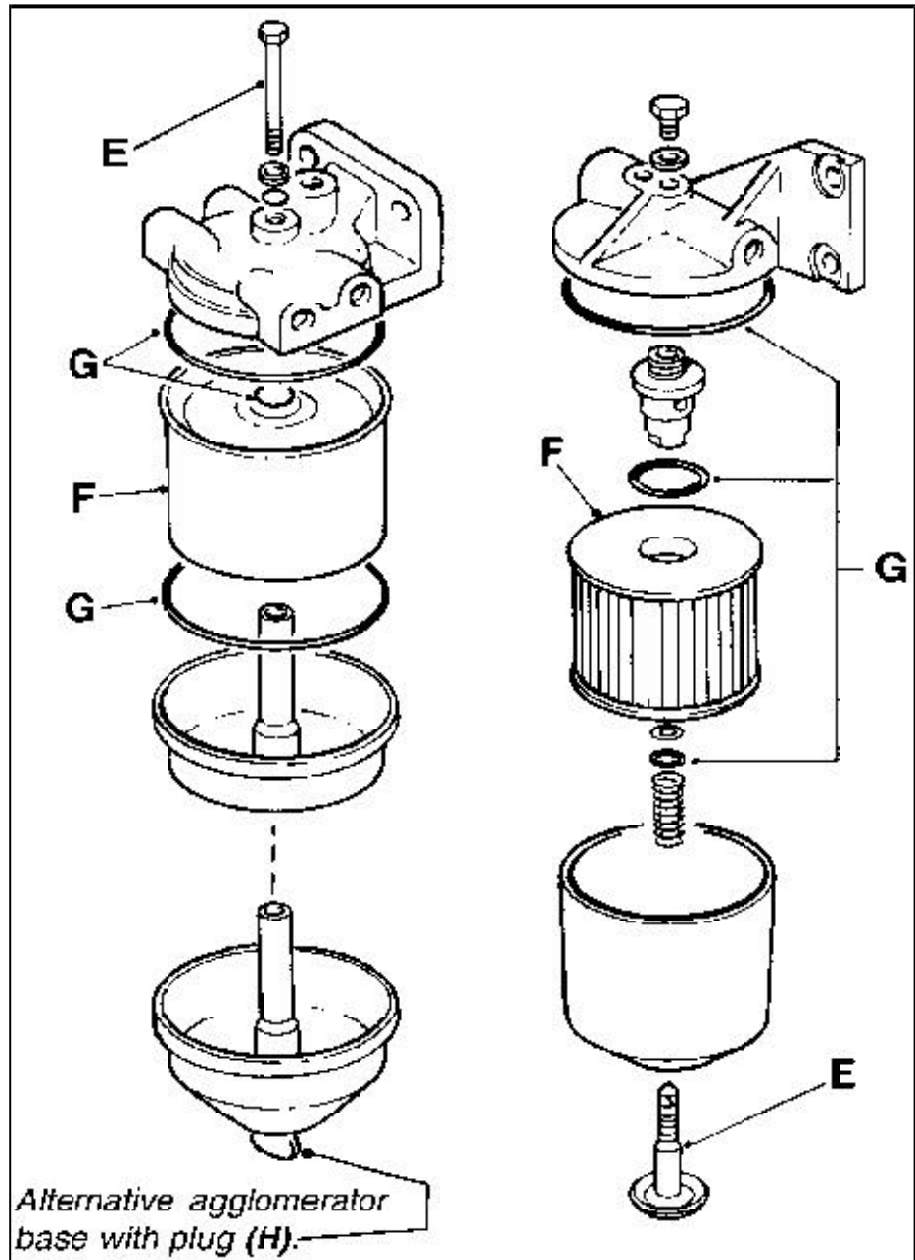

Change Cartridge Agglomerator as follows:

The cartridge agglomerator should be renewed more frequently than every 500 hours, if for any reason the fuel is known to be dirty.

To change the cartridge agglomerator:

Use a suitable strap wrench to unscrew the cartridge (M) from the head (N).

DO NOT USE A STRAP WRENCH TO FIT THE NEW CARTRIDGE! Screw a new cartridge onto the head and hand tighten only.

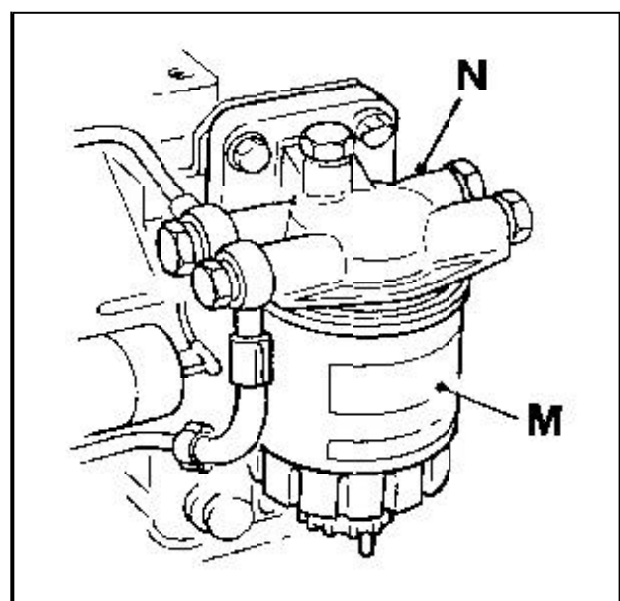

ENGINE

Priming the fuel system

Prime the system as follows:

Fill the fuel tank

Move the engine control lever to the RUN position.

Release the bleed screw **(O)** on the filter head, then operate the priming lever **(P)** on the lift pump until a full air free flow is obtained

Retighten bleed screw **(O)**

Vent each injector pump in turn by releasing screw **(R)**, then operate the priming lever **(P)** on the lift pump until a full air free flow is obtained

Retighten bleed screw **(R)**, then repeat for the other injector pump.

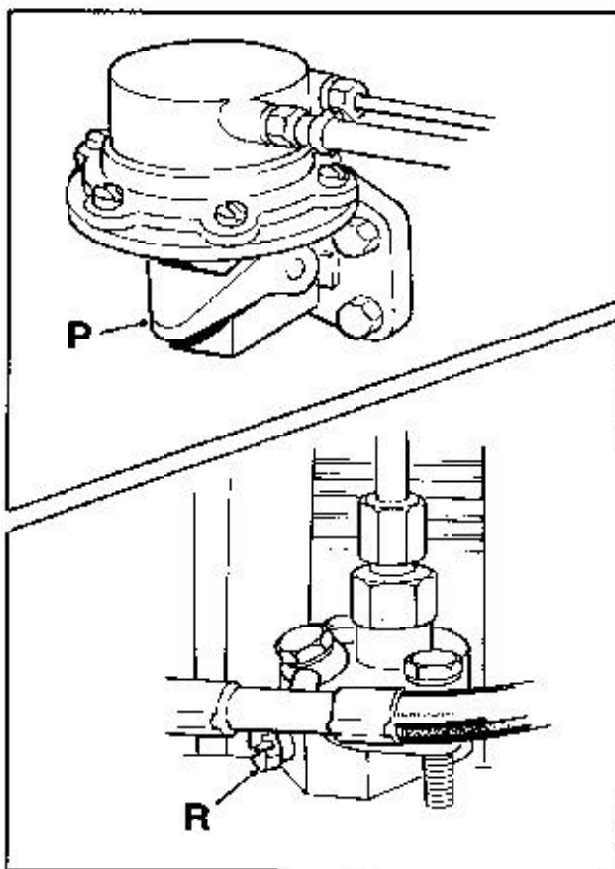
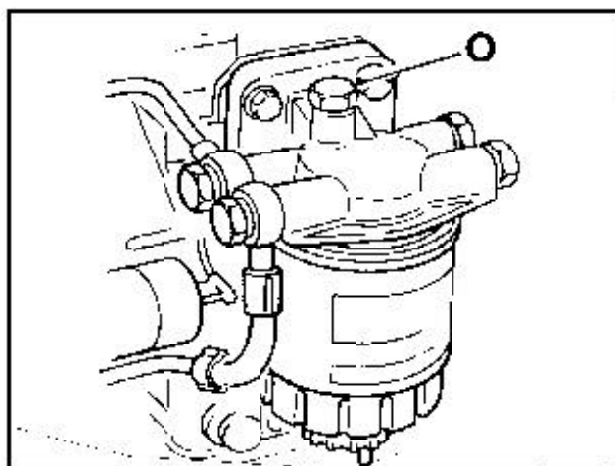

Every 10 operating hours, or daily

Air cleaner: clean/replace

Clean or replace the outer element (A) under very dusty conditions as described below:

Every 125 operating hours

Air cleaner: clean/replace

Clean or replace the outer element (A) under *moderately* dusty conditions as described below:

Access the elements by unhooking the retaining clips and removing the cover.

Remove the outer element (A) and clean or replace it as necessary.

Replace the element.

Replace the cover with the inlet facing downwards.

WARNING *No attempt must be made to clean the inner element (B).*



After the outer element (A) has been cleaned three times the inner element (B) must be replaced.

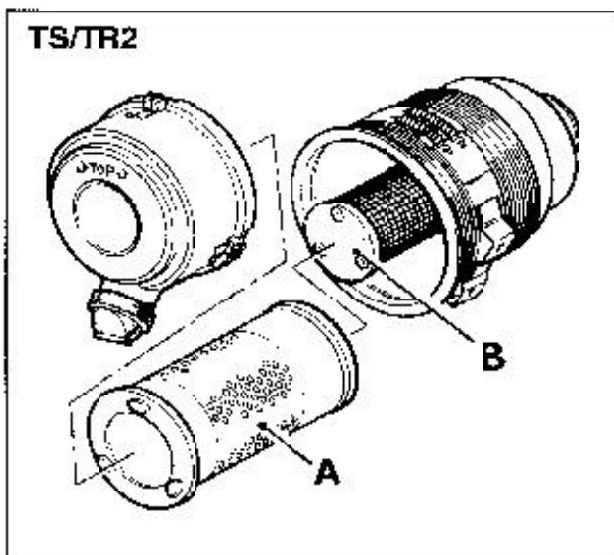

GEARBOX

Safe handling of oils

WARNING Do not allow oils to come into regular contact with skin. This can lead to serious skin diseases. Medical evidence suggests they may include skin cancer.



Always wear protective gloves when handling oils for topping up, draining, or refilling.

Dispose of waste oil into waste oil storage tanks. If storage tanks are not available, consult your Distributor or local authority for addresses of local designated disposal points.

It is illegal to dispose of waste oil into drains or water courses or to bury it.

Every 50 operating hours, or weekly

Check gearbox oil level

Check the gearbox oil level when the machine has stood for 2 minutes.

Clean the area around the dipstick/filler (V) before removing.

Remove the dipstick and check the oil level. Top-up between the two marks (W). It is most important not to overfill.

For the correct type and grade of oil, see "Specifications".

Every 1000 operating hours

Change gearbox oil

Clean the areas surrounding the dipstick (V) and drain plugs (X).

Place a suitable container beneath the drain plug.

CAUTION: Before removing the drain plug be sure to stand to one side to avoid the oil that will spill from the hole.

Remove the drain plug (X) and drain the gearbox. (Do not lose its sealing washer)

Replace drain plug with its sealing washer.

Remove the dipstick (V) from the filler hole.

Fill with oil. Check that the final level is between the two marks on the dipstick. It is most important not to overfill.

For the correct type and grade of oil, see "Specifications".

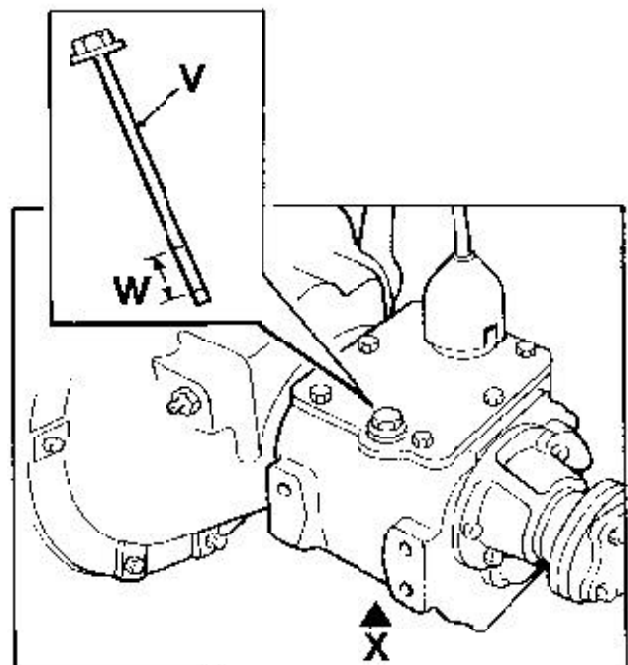

Every 50 operating hours, or weekly

Check transfer gearbox oil level

Clean the area surrounding the filler/level plug (Y) before removing it.

Check and top-up through the filler/level plug hole (Y) until the oil is level with the bottom of that hole.

For the correct type and grade of oil, see "Specifications".

Every 1000 operating hours

Change transfer gearbox oil

Place a suitable container beneath the drain plug (Z).

Drain oil by removing the plug (Z). (*Do not lose its sealing washer*)

Replace drain plug with its sealing washer.

Fill with oil at filler/level plug (Y) to the correct level. Replace filler/level plug with its sealing washer.

For the correct type and grade of oil, see "Specifications".

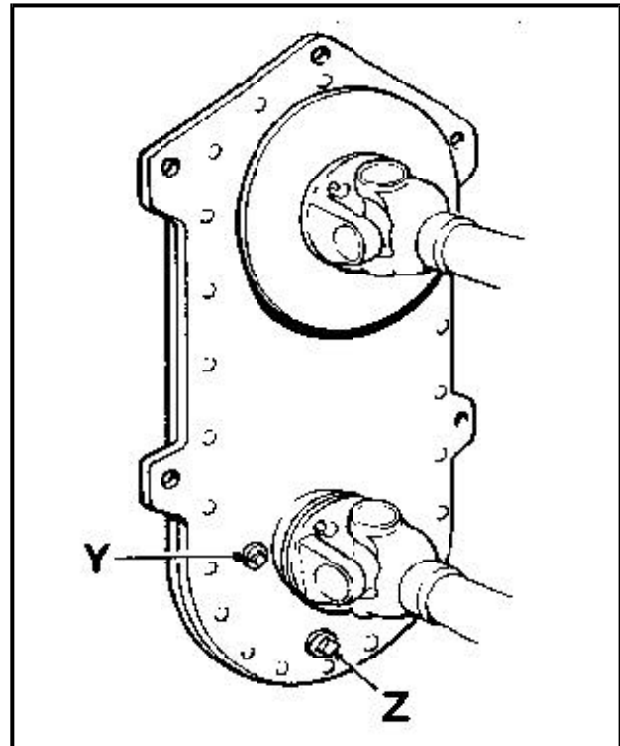

PROPELLER SHAFT**Propeller shaft Installation**

ALWAYS ensure that the larger yoke (X) of the propeller shaft is fitted to the transfer box, NOT the smaller yoke (Y).

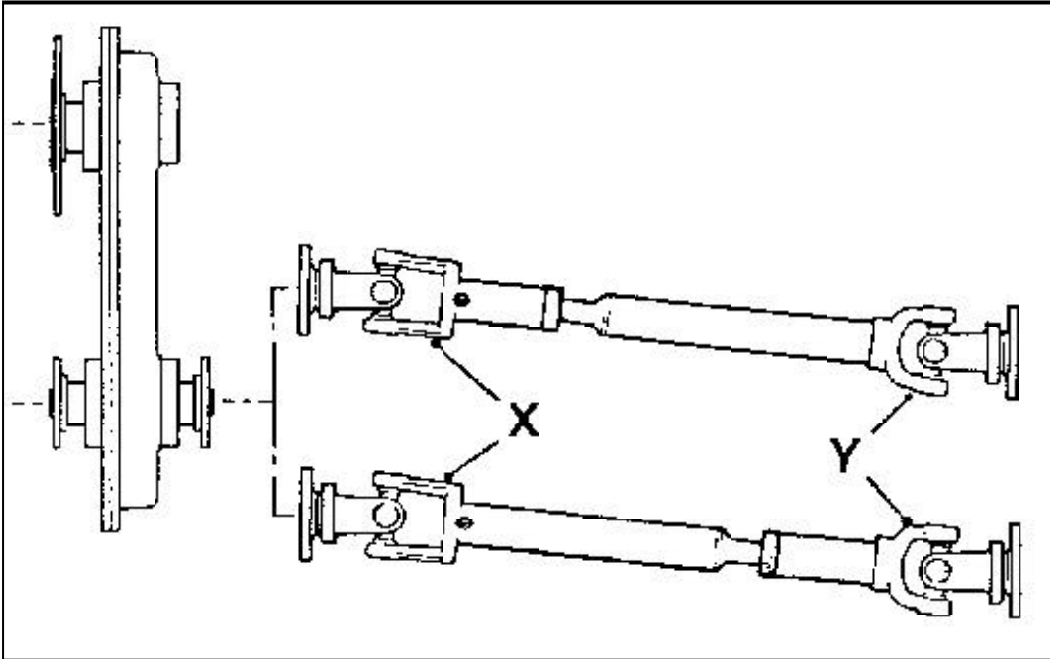

Safe handling of batteries

WARNING *The battery contains a sulphuric acid electrolyte which can cause severe burns and produce explosive gases.*



Wear protective clothing, gloves and goggles when servicing the battery.

Avoid contact with the skin, eyes or clothing. If spilled onto the skin, flush immediately with cold water. If splashed into the eyes, flush immediately with cold water for 15 minutes and get prompt medical attention.

Do not take internally. If accidentally swallowed, call a doctor immediately.

Do not use a naked flame or smoke near the battery. Do not produce sparks with cable clamps when charging the battery or starting the engine with a slave battery.

Always disconnect battery leads, or activate battery isolater where fitted, before carrying out any maintenance to the electrical system.

ALWAYS dispose of unserviceable batteries safely. Comply with local byelaws and national regulations on the disposal of hazardous waste. Consult your local authority for addresses of local designated disposal points.

Every 50 hours

Check battery electrolyte level

The battery is situated beneath a cover on the left-hand side of the dumper.

Ensure that the electrical connections are clean and tight, and coat the terminals with petroleum jelly to protect them from corrosion.

Remove battery filler plugs and check that the electrolyte level is between 6 - 9 mm (0.25 - 0.37 in) above the tops of the separators.

If necessary, top-up with distilled water.

Replace battery filler plugs and tighten securely.

Battery removal

WARNING *If the battery is to be removed from the machine, ensure the following procedure is used.*



Switch the engine off.

Remove the starter key from the machine.

Ensure all electrical circuits are switched off. Activate the battery isolater, where fitted.

Remove the battery cover and clamp.

Disconnect the earth (-) lead from the battery before removing the positive(+) lead.

Lift the battery from the machine.

WARNING *When installing the battery, the positive (+) lead MUST be connected first.*



HYDRAULIC SYSTEM

Hydraulic System Safety (see also "Safe Working" section)

WARNING Do not allow oils to come into regular contact with skin. This can lead to serious skin diseases. Medical evidence suggests they may include skin cancer.



Always wear protective gloves when handling oils for topping up, draining, or refilling.

Always practise the greatest cleanliness when servicing hydraulic components.

Always clean the areas surrounding filler points, filters etc., before and after servicing.

Dispose of waste oil into waste oil storage tanks. If storage tanks are not available, consult your Distributor or local authority for addresses of local designated disposal points.

It is illegal to dispose of waste oil into drains or water courses or to bury it.

Description of hydraulic system

The hydraulic system provides power for skip tipping.

The main components consist of:

Tank: The tank is filled through a filler/strainer which incorporates an oil level indicator. The filler cap is fitted with a breather. In the bottom of the tank is a suction strainer.

Pump: The pump is driven directly from the engine.

Filter: The filter is situated in the return to tank hose from the control valve.

Tipping control valve: The control valve receives oil from the pump and delivers it to the skip tipping rams. The rate of oil flow to the rams is proportional to the distance that the control valve lever is moved.

If the control lever is held either fully forward or backward after the rams have reached their full stroke, a relief valve opens, allowing the oil to return to the tank.

Note: Hydraulically rotated skips

Hydraulically rotated skips on the 4B2000 utilise a load sensing steer valve and a separate priority valve.

Dumping hydraulic pressure

WARNING Always dump all hydraulic pressure from the system before servicing any hydraulic component.



To dump pressure:

Stop the engine.

Move the skip control lever several times in each direction.

Dumpers with hydraulically rotated skips

The tank, filter, pump and steering circuit operate in basically the same manner as for the conventional forward tipping skip. (see the previous and following pages), with the addition of a load sensing steer valve and a separate flow priority valve.

Skip rotation

The skip is operated by a four-way joystick control valve.

Joystick control valve: The control valve (7) receives oil from the pump and delivers it to either the tipping rams (8), or the swivel rams (9). The rate of oil flow to the rams is proportional to the distance that the joystick lever is moved.

If the lever is held in one of its most extreme positions (either left/right or forwards/backwards, after any of the rams have reached their full stroke, a relief valve opens, allowing the oil to return to the tank.

Because the joystick is fitted with a gate it is not possible to move the lever diagonally, therefore it is not possible to tip and swivel simultaneously.

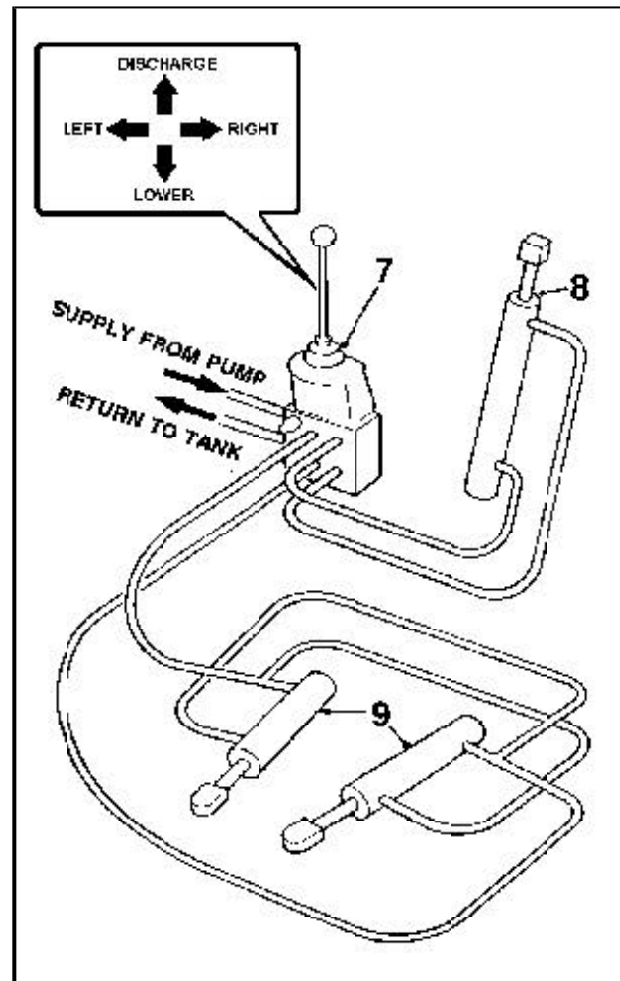

Hydraulic system

Standard skips are fitted with two rams

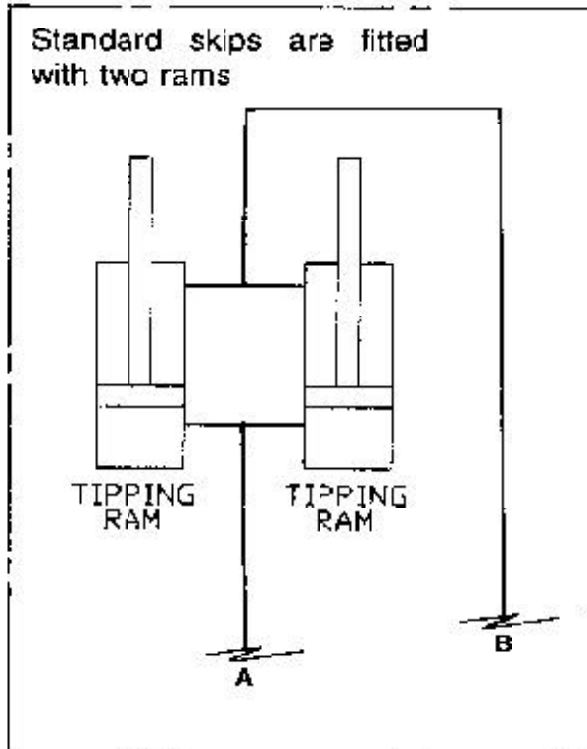

High discharge and rotating skips are fitted with one ram

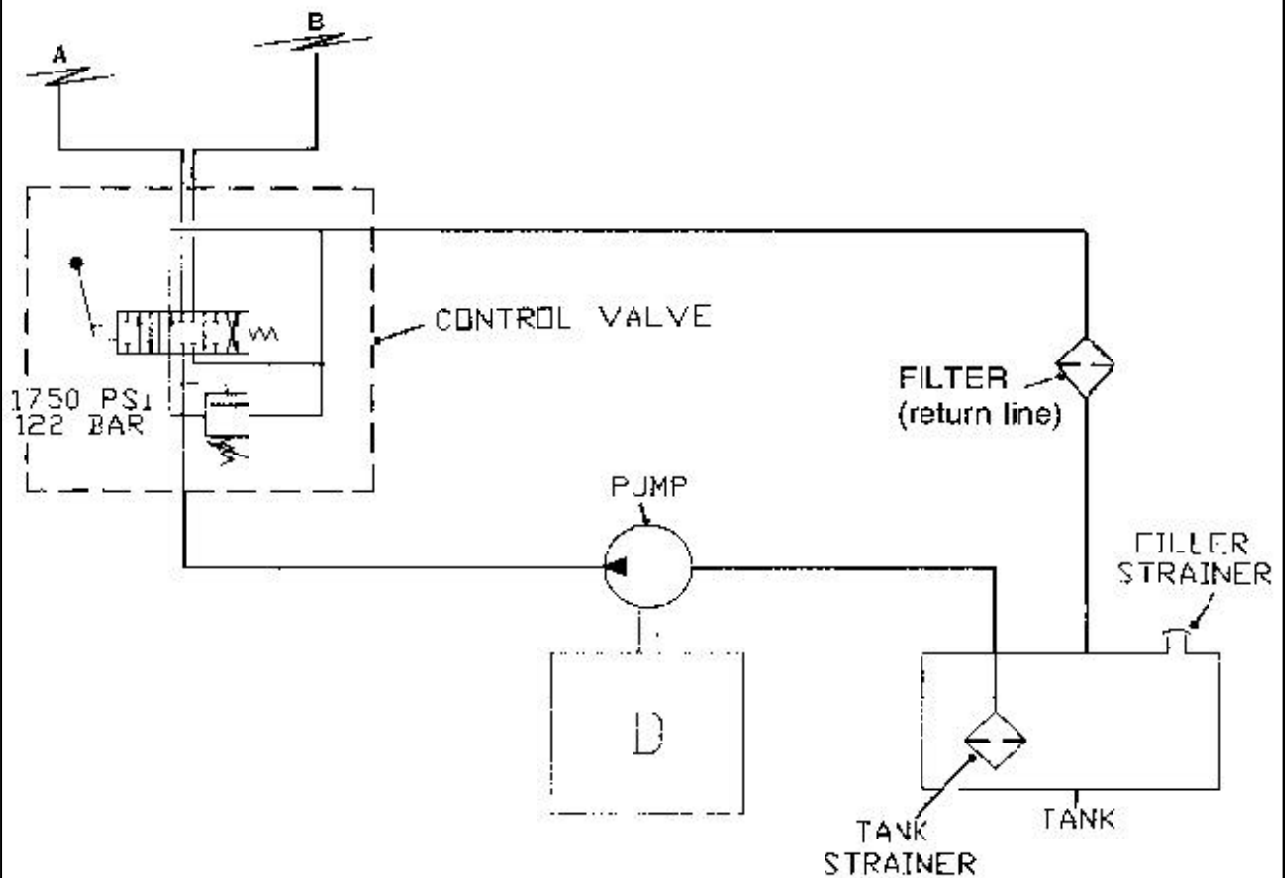
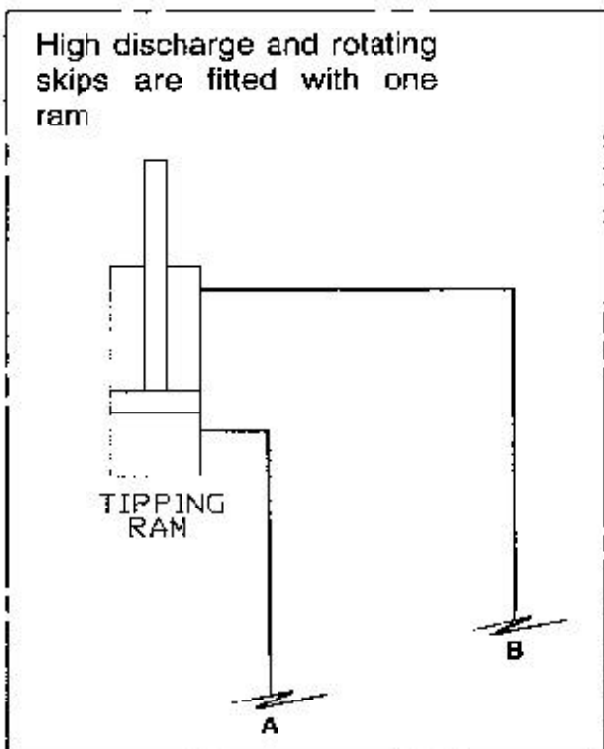

HYDRAULIC SYSTEM

Hydraulic System Checks

If the hydraulic system fails to operate completely, or does so extremely slowly, carry out the following procedures.

Check that the hydraulic tank is full of oil to the correct level. The level is correct when oil is 50mm from the top of the filler neck.

Check that the filter has been regularly cleaned in accordance with the maintenance schedule. If not, clean filter.

Check that the hydraulic pressures are correct as follows:

Tipping circuit

Fit a 2000 lb/in² gauge into the hydraulic system at the base of a skip ram.

Operate control lever to tip skip and check the pressure reading on the gauge when the rams are fully extended and the relief valve is 'blowing'. See "Specifications" for correct pressure.

Steering circuit

Fit a 2000 lb/in² gauge into the hydraulic system at the base of the steering ram.

Turn the steering wheel until the machine is at 'Full Lock' and check the pressure reading on the gauge. See "Specifications" for correct pressure.

If these procedures do not correct the fault, contact your Distributor.

Periodically check the hose between the pump and the hydraulic tank to ensure that it is not deformed. Any deformation in the hose may result in a restricted flow and damage to the pump.

Every 10 operating hours, or daily

Check hydraulic oil level

Do not check oil level before closing the tipping rams, and the engine has been stopped for 2 minutes.

Always clean the surrounding area before removing the cap to prevent dirt from entering the tank.

The oil level is correct when it is 50mm (2") from the top of the neck.

Do not overfill; it will cause leakage from the breather!

First 100 operating hours

Clean / change tank strainer

WARNING Before cleaning the tank strainer, stop the engine and dump hydraulic pressure.



Place a *clean* suitable container beneath the hydraulic tank strainer. Clean the area surrounding the strainer.

Disconnect the hose, then carefully unscrew the strainer (C) from the tank allowing the oil to drain into the container.

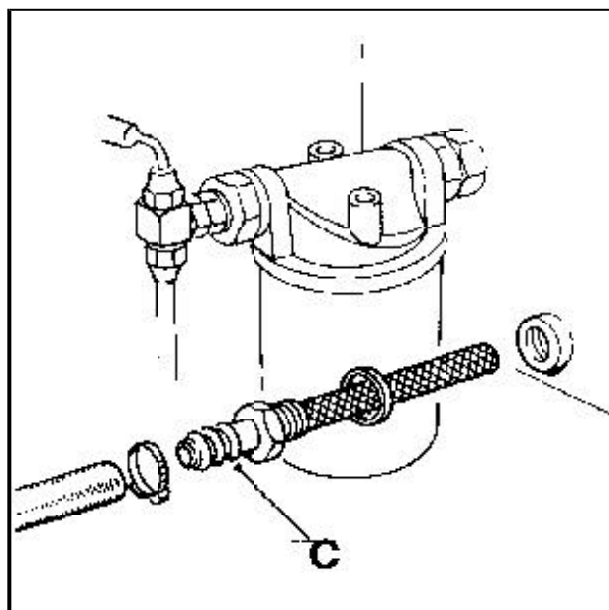

Provided that the oil does not become contaminated it can be used to refill the tank after the strainer has been cleaned and replaced.

Wash the strainer in white spirit and check it for any damage. *If the strainer cannot be thoroughly cleaned, fit a new one.*

Screw the strainer back into the tank. Reconnect the hose.

Fill the tank with oil. (The oil level is correct when it is 50mm below the top of the filler neck. *For the correct type of oil, see "Specifications".*)

Run the engine to circulate the oil.

Operate the hydraulic control to purge any air from the system.

Stop the engine and top up the tank as required.

Check the areas around the strainer for leaks.

First 100 operating hours

Change Hydraulic Filter Element

WARNING *Before changing the filter element, stop the engine and dump hydraulic pressure.*



Remove and discard element cartridge (**S**). Clean joint area, wipe with hydraulic oil, and fit new element cartridge. Do not over tighten.

Run engine to circulate the oil.

Operate the hydraulic control to purge any air from the system.

Stop the engine and top up the tank as required. (*For the correct type of oil, see "Specifications".*)

Check the area around the element for leaks.

Every 300 operating hours

Change filter element

Change the filter element, using the procedure described in the previous "First 100 operating hours".

Every 1000 operating hours

Clean/change tank strainer

Clean or change the hydraulic tank strainer (**C**), using the procedure described in the previous "First 100 operating hours".

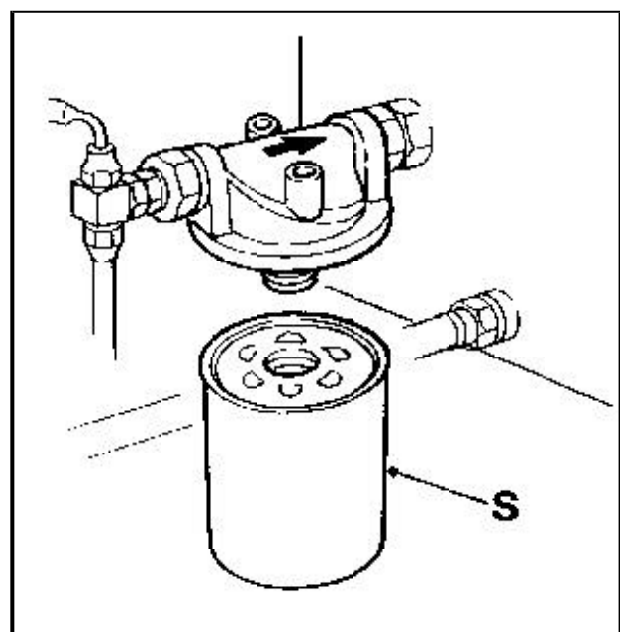

HYDRAULIC SYSTEM**Every 1000 operating hours****Change hydraulic oil**

Run the engine and operate the hydraulics to warm the oil.

Fully close the tipping rams.

Switch off the engine and dump hydraulic pressure.

Clean the area surrounding the hydraulic tank strainer and filler cap.

Place a suitable container on the ground beneath the strainer to catch oil.

CAUTION: Before removing the strainer be sure to stand to one side to avoid the oil that will spill from the hole.

Carefully remove the strainer and drain the oil from the tank.

Flush out the tank with clean hydraulic oil, taking extreme care to remove all dirt and foreign matter.

Refit the strainer.

Clean the filler cap breather.

Refill the tank with clean oil of the correct type and grade. For the correct type of oil, see "*Specifications*".

Run the engine to circulate the oil.

Operate the hydraulic control to purge any air from the system.

Stop the engine and top up the tank as required.

Check the area around the strainer for leaks.

Every 50 operating hours, or weekly

WARNING Always use lubricants of the grade specified.



Always lubricate and service **BEFORE** work commences, and **WITHIN** the periods specified.

Grease points

Clean nipples **BEFORE** and **AFTER** greasing. Apply the grease gun until clean grease appears.

Location of grease points

- A** Tipping rams (2 on each ram)
[No grease points on Rotating or High discharge skip tipping rams]
- B** Skip pivots (2)
- C** Propeller shaft (3)
- D** Brake pedal pivot (2)
- E** Clutch pedal pivot (2)
- F** Accelerator pivot (2)
- G** Front/rear chassis centre pivot (2)
- H** Rear axle centre pivot (2)
- I** Handbrake cable (1)
- J** Gearbox clutch shaft pivot (1 each side of gearbox bell-housing)

Clean and lubricate all linkages not fitted with a grease nipple.

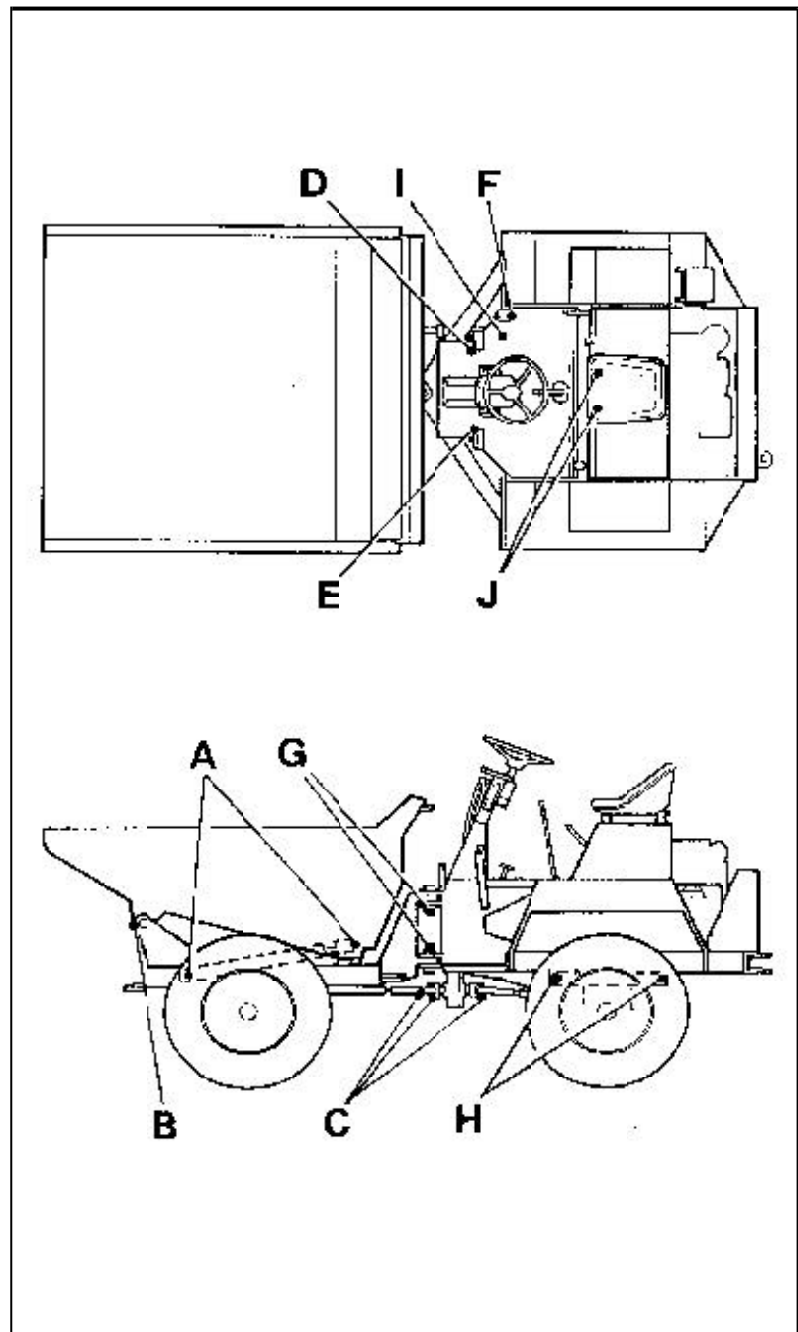

BRAKING SYSTEM***Salisbury axles*****Brake System**

The service brakes consist of calipers acting upon dry discs.

The brake system is designed to require the minimum of maintenance, and providing the hydraulic fluid in the reservoir is not allowed to fall below the recommended level, no defects should normally occur.

Fluid loss must be supplemented by topping up the reservoir with brake fluid that conforms to SAE. J1703. No other fluid may be used.

If air is present in the system, it will be indicated by sluggish response and by spongy action of the brake pedal. This may be due to air being introduced at a loose joint or by the reservoir fluid level being allowed to fall very low. These defects must be remedied immediately and the complete system bled.

To bleed the system, proceed as follows:

A Check that all connections are tight and all bleed screws are closed.

B Fill reservoir with the correct fluid.

C Attach bleeder tube (1) to one of the bleed screws (2) and immerse other end in a small quantity of brake fluid contained in a glass jar (3).

Slacken bleed screw and operate brake pedal up and down to its full stroke until fluid pumped into jar contains no air bubbles. Hold down pedal and close bleed screw.

Remove bleeder tube and release pedal.

D Repeat on other caliper.

E Continue until all air has been bled from the system.

F Lock both bleed screws and top up reservoir to the correct level.

G Apply normal working load on brake pedal for two or three minutes and examine entire system for leaks.

Note: During operation it is essential that the reservoir levels are kept topped up to prevent further air being drawn into the system. Only use new fluid for topping up.

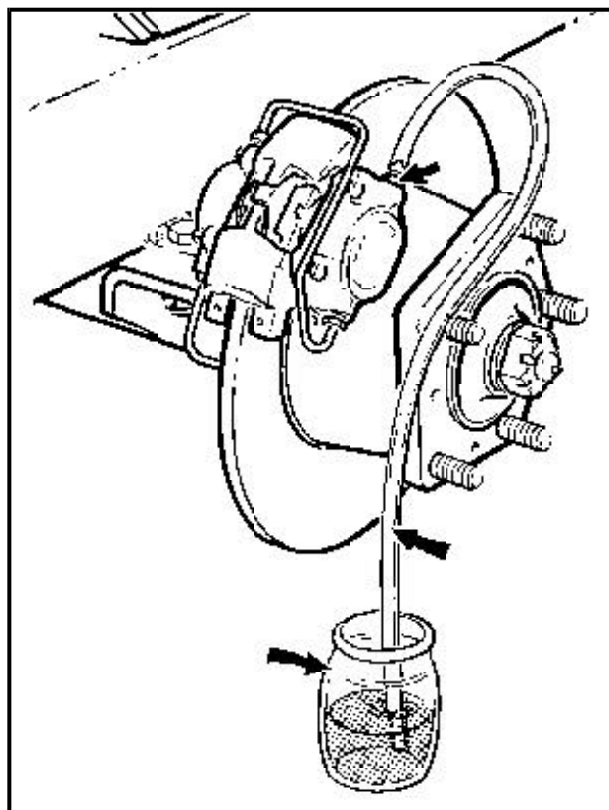

Newage axles

Brake System

The service brakes consist of totally sealed oil immersed multi-discs fitted within the front axle. (The rear axle only has brakes fitted as an option.)

The brake system is designed to require the minimum of maintenance, and no defects should normally occur.

If air is present in the system, it will be indicated by sluggish response and by spongy action of the brake pedal.

To bleed the system, proceed as follows:

- A** Check that all connections are tight and the bleed screws are closed.
- B** Check that there is sufficient oil in the hydraulic tank.
- C** Attach bleeder tube (1) to the bleed screw (2) on the front axle and immerse the other end of the tube in a small quantity of hydraulic oil contained in a glass jar (3).
Slacken bleed screw and depress the brake pedal to its full extent. Hold the pedal down and tighten bleed screw. Release pedal and wait 5 to 10 seconds. Slacken the bleed screw and repeat process until the oil pumped into the jar contains no air bubbles. Hold down the pedal and close the bleed screw.
Remove bleeder tube and release pedal.
- D** Lock the bleed screw.
- F** If the dumper is fitted with four wheel braking, repeat the above procedure on the rear axle.
- G** Apply normal working load on brake pedal for two or three minutes and examine the entire system for leaks. Check the oil level in the hydraulic tank.

Note: Always ensure that free play of 1 to 2 mm exists between the master cylinder push rod and the piston when the brake pedal is released.

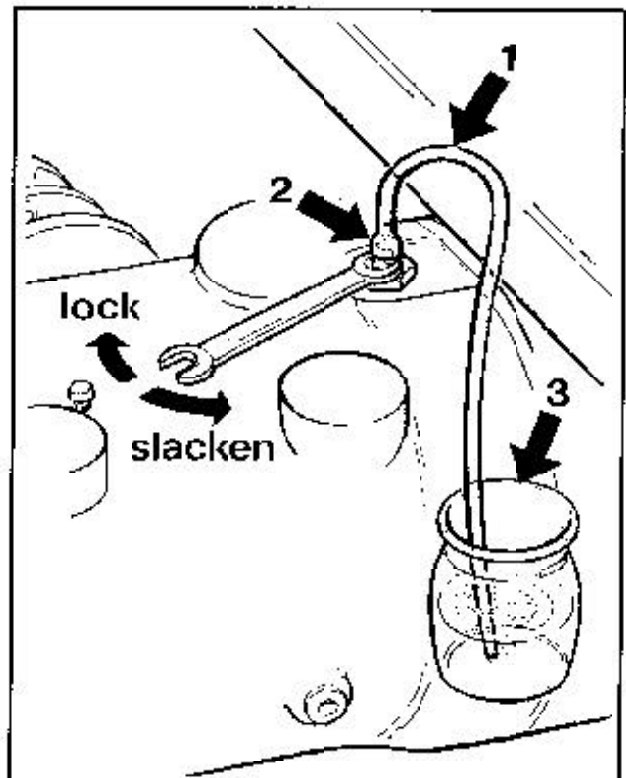

WHEELS & TYRES

Every 10 operating hours, or daily

Wheel nuts

Tighten wheel nuts whenever necessary, every ten hours or daily.

After a wheel change, the nuts should be checked several times a day until they maintain their correct setting.

For wheel nut tightening torque, see "Specifications".

Every 50 operating hours, or weekly

Tyre pressures

WARNING *ALWAYS ensure that when adding air to a tyre the area is clear of personnel.*



NEVER over-inflate a tyre beyond its specified pressure.

NEVER adjust the tyre pressure in an attempt to improve traction on soft ground or obtain a softer ride on hard ground. Incorrectly adjusted tyres can affect the steering and handling characteristics.

Check the tyre pressures only when the tyres are cold.

For correct pressures see "Specifications".

Tyre condition

Check the tyres for damage and deterioration.

Every 10 operating hours, or daily

Check for leaks

Check for oil leaks around joints and seals.

Every 50 operating hours, or weekly

Tighten securing nuts

Tighten axle arm/main case joint securing nuts and half shaft nuts.

Axle oil level

Do not check the oil level until the machine has stood for 2 minutes.

Clean the area surrounding level plug (E) before removing it.

The oil is correct when level with the bottom of the level plug hole.

If the level is low, top-up with clean oil of the correct grade through the filler (D).

Replace plugs.

For the correct type and grade of oil, see "Specifications".

Every 1000 operating hours

Axle oil change

Change the lubrication oil in the front axle as follows:

Clean the area surrounding the filler (D), level (E) and drain (F) plugs.

Place a suitable container beneath the drain plug.

CAUTION: Before removing the plugs be sure to stand to one side to avoid the oil that will spill from the drain hole.

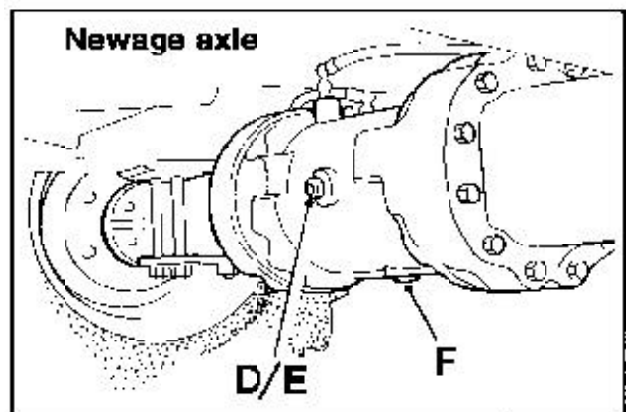
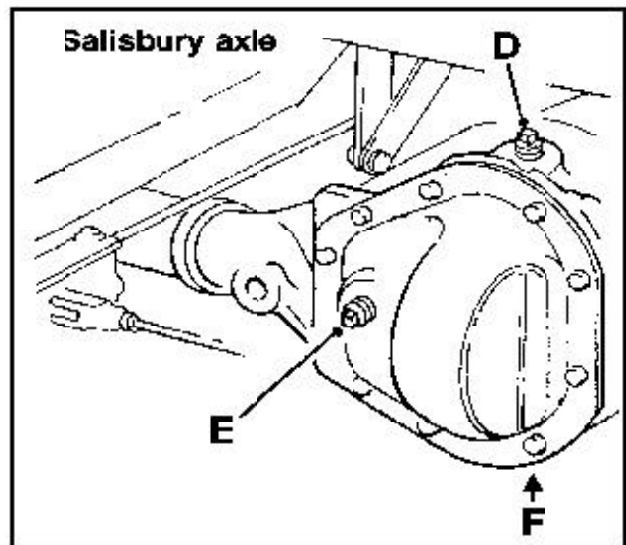

Remove drain plug (F) and drain oil from the casing. Replace drain plug.

Refill at the filler plug (D) with clean oil of the correct grade.

The level is correct when oil reaches the bottom of the level plug hole (E).

Replace all plugs.

For the correct type and grade of oil, see "Specifications".

TECHNICAL INFORMATION

4.1

DIMENSIONS

Machine Model	Earth skip	High discharge
A Overall height	1.83 m	1.83 m
B Skip loading height	1.33 m	1.55 m
C Wheel base	1.79 m	1.79 m
D Overall length	3.55 m	3.27 m
E Ground clearance	0.20 m	0.20 m
F Overall width	1.76 m	1.76 m
G Skip discharge height	0.57 m	1.45 m
H Maximum skip height when tipped	2.31 m	2.73 m
J Skip discharge forward of tyres	0.56 m	0.32 m
L Track	1.53 m	1.53 m
M Skip discharge width	1.42 m	0.67 m
Rear axle articulation	0.30 m	0.30 m
Turning circle	7.45 m	7.45 m

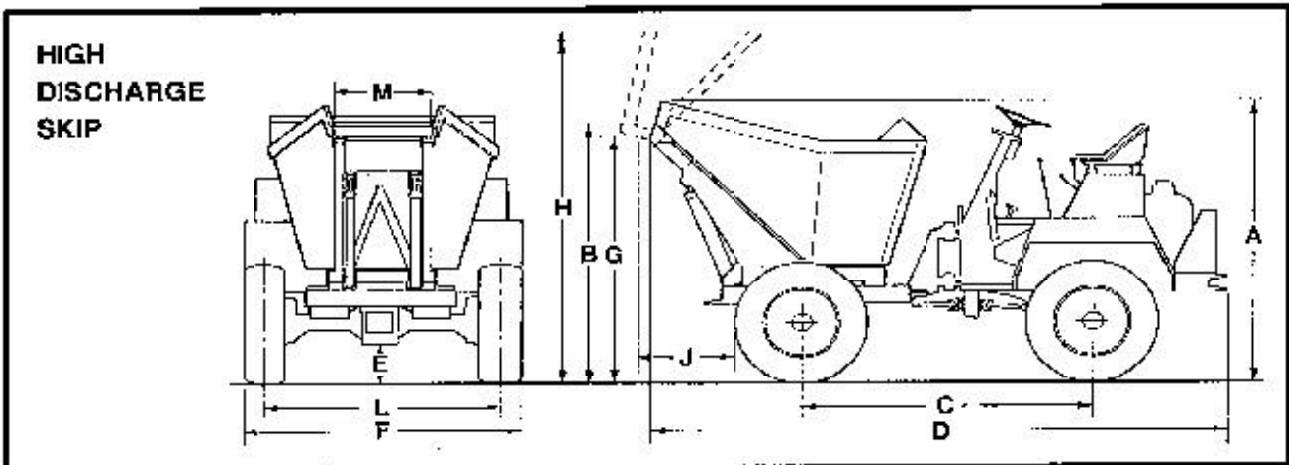
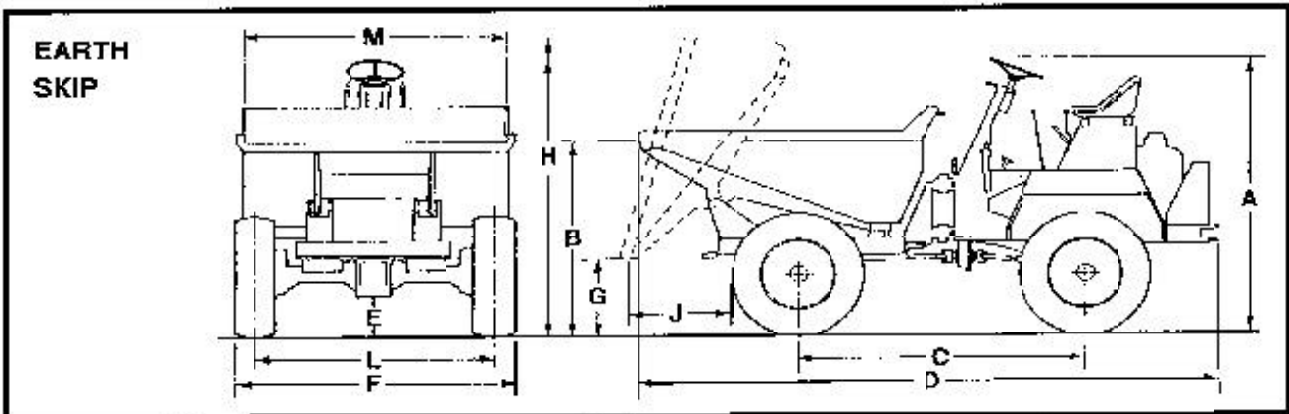

4.1A

TECHNICAL INFORMATION

DIMENSIONS

Machine Model	Manual rotating skip	Hydraulic rotating skip
A Overall height	1.83 m	1.83 m
B Skip loading height	1.44 m	1.35 m
C Wheel base	1.79 m	2.10 m
D Overall length	3.71 m	3.67 m
E Ground clearance	0.20 m	0.20 m
F Overall width	1.76 m	1.76 m
G Skip discharge height	0.57 m	1.33 m
H Maximum skip height when tipped	2.48 m	2.77 m
J Skip discharge forward of tyres	0.71 m	0.30 m
L Track	1.53 m	1.53 m
M Skip discharge width	0.51 m or 1.07 m	1.40 m
Rear axle articulation	0.30 m	0.30 m
Turning circle	7.45 m	8.20 m

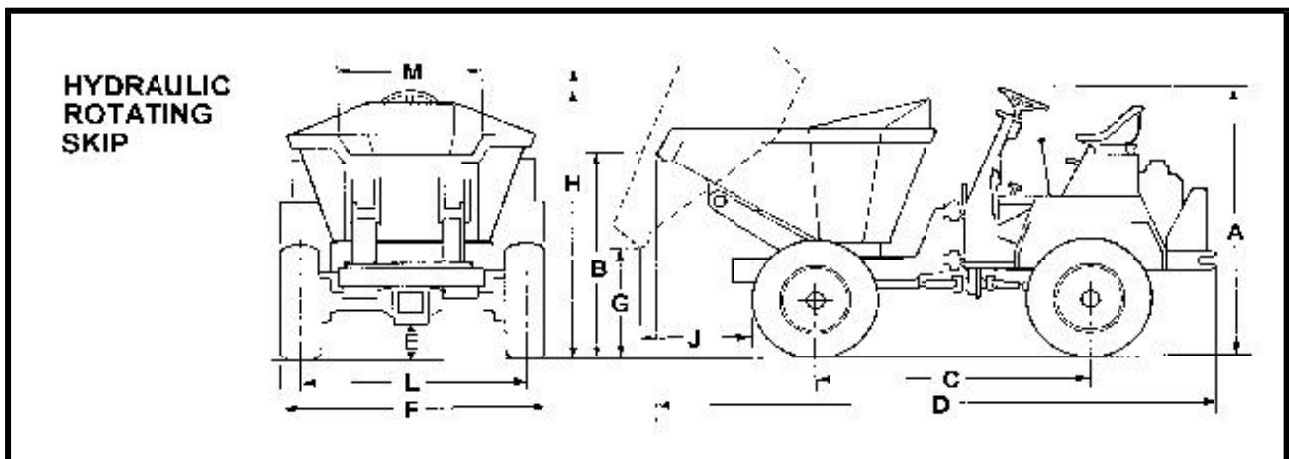
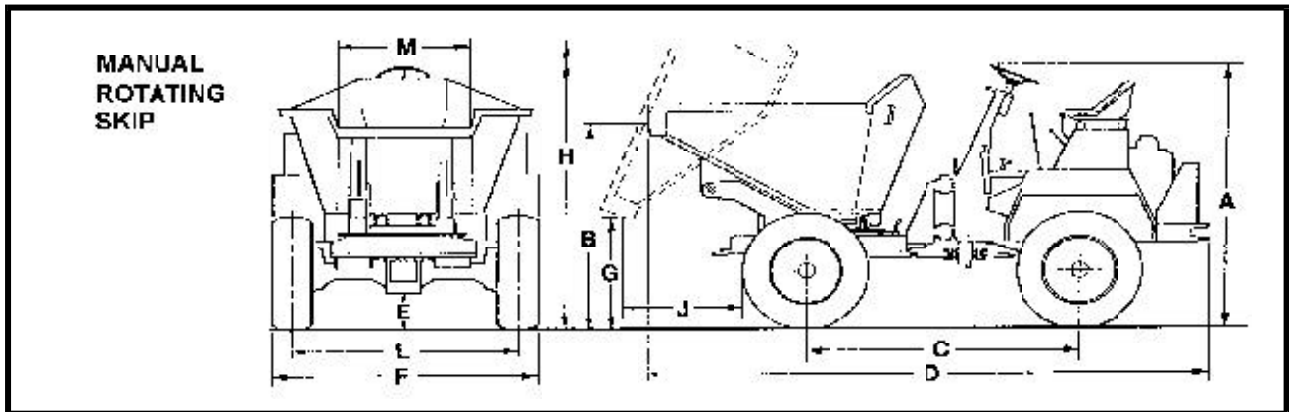

SPECIFICATIONS

ENGINES

up to 1985	Petter PH2:	<i>"See relevant Engine Operator's handbook".</i>
	Lister ST2:	<i>"See relevant Engine Operator's handbook".</i>
1985 to 1989	Lister-Petter PH2:	<i>"See relevant Engine Operator's handbook".</i>
1985 to 1989	Lister-Petter TS2	Twin cylinder, direct injection, naturally aspirated, flywheel fan air cooled diesel. Rotation: Anti-clockwise when looking on the flywheel. TS2: Output: 15.6 kW (20.9 bhp) @ 2500 rev/min. TR2: Output: 19 kW (25.4 bhp) @ 2500 rev/min.
1989 to date	Lister-Petter TR2:	

NOTE FROM 1989 TO DATE THE LISTER-PETTER TS2 HAS BEEN OFFERED AS AN OPTION.

ELECTRICS	(Where fitted)	12 volt negative earth.
FUEL SYSTEM	System:	Two element fuel pump.
	Fuel specification:	BS 2869:1988 Class A2, or BS EN590:1995 Class A1
	Fuel tank capacity:	29.5 litres
	Fuel filter:	Strainer within fuel tank.
	Air cleaner:	Renewable element.
AXLES (Newage)	Front & rear:	Heavy duty with fully floating half shafts.
BRAKES	Service:	Front axle braking. Totally sealed oil immersed multi-plate disc brakes, featuring fully automatic adjustment for wear. (Optional rear axle braking).
	Parking:	Hand operated, ratchet type, actuating a disc brake caliper mounted on the transmission.
TRANSMISSION	Heavy duty constant mesh gearbox, with 3 forward and 1 reverse gear.	
HYDRAULICS	Pump:	Gear type.
	Control valve:	Sectional or monobloc with pressure relief valve.
	Filter:	Strainer within the hydraulic tank, plus an in-line filter.

ROAD SPEEDS

	1st Gear Km/h (mph)	2nd Gear km/h (mph)	3rd Gear km/h (mph)	Reverse km/h (mph)
Petter PH2	3.6 (2.2)	8.4 (5.2)	16.1 (10.0)	4.0 (2.5)
Lister ST2 and Lister-Petter TS/TR2	4.3 (2.7)	10.0 (6.2)	18.5 (11.5)	4.8 (3.0)

LUBRICANTS AND FLUIDS Total oils (factory fill)

Capacities

TS/TR2 Engine Lub. Oil	Rubia H 10W/30	2.7 litres
<i>Note: For engine oils used in temperatures above 30°C consult the Engine Handbook.</i>		
Gearbox	Rubia B 20W/30	2.0 litres (approx)
Transfer Box	EP85W/140 or EP140 gear oil	1.00 litre (approx)
Axles (<i>Newage, with brakes</i>)	Universal plant oil or Transmission MP	3.5 litres
(<i>Newage, without brakes</i>)	"	2.5 litres
(<i>Salisbury</i>)	Gear oil SAE 90 EP	-----
Brake System (<i>Supplied from hydraulic tank</i>)	Azzola ZS46	-----
Hydraulic System	Azzola ZS46	29.5 litres (tank)
General Grease	Multis EP2	as required
General Lubrication Oil	Rubia B 20W/30	as required

TYRE PRESSURES

Front	2.35 bar	(35 lb in ²)
Rear	2.35 bar	(35 lb in ²)

ADJUSTMENTS

Wheel nuts torque	200 lbf ft (271 Nm)
Engine	(See Engine Workshop Manual)

TYRES

Newage Axles	
<i>Standard</i>	11.5/80 x 15
<i>Alternative</i>	7.5 x 16
<i>(not to be used on rotating skips)</i>	
Salisbury Axles (Obsolete)	
	10/75 x 15

HYDRAULIC PRESSURE

120.7 bar (1750psi)
138 bar (2000psi) <i>hyd. rotating skips only</i>

4.4

TECHNICAL INFORMATION

SPECIFICATIONS

CAPACITIES

SKIP TYPE			
	Standard	High discharge	Rotating
Payload	2000 kg	2000 kg	1630 kg (up to serial no.1092) 2000 kg (from serial no.1093)
Water level	850 litres	760 litres	935 litres
Struck	1100 litres	800 litres	992 litres
Heaped	1500 litres	1207 litres	1304 litres

MACHINE WEIGHTS

MODEL, skip type			
	Standard	High discharge	Manual rotating skip
	1739 kg	1875 kg	1857 kg

VIBRATION DECLARATION

Whole body vibration level a_w (m/s^2) :- 0.7 - 0.8 Typical*

* **Note:** *The absence of a harmonised test code together with the variable conditions under which this equipment may be used allows only representative figures to be quoted.*

Hand/arm vibration level a_{ha} (m/s^2) :- Less than 2.5

(Vibration declaration applicable only to EEC models)

MAIN ELECTRICAL CIRCUIT (without road lights)

Later dumpers with Lister-Petter 'NISCA' charging system

WIRING COLOUR CODES		
1	STARTER MOTOR-REG 'B'	RED (THICK)
2	START SWITCH TER 1-STARTER MOTOR	BROWN
3	START SWITCH TER 3-STARTER SOLENOID	WHITE/RED
4	START SWITCH TER 4-REG 'C'	RED (THIN)
5	REG 'LE' WARNING LAMP	BLACK
6	START SWITCH TER 4- LAMP	BLACK (BRIDGE WIRE)

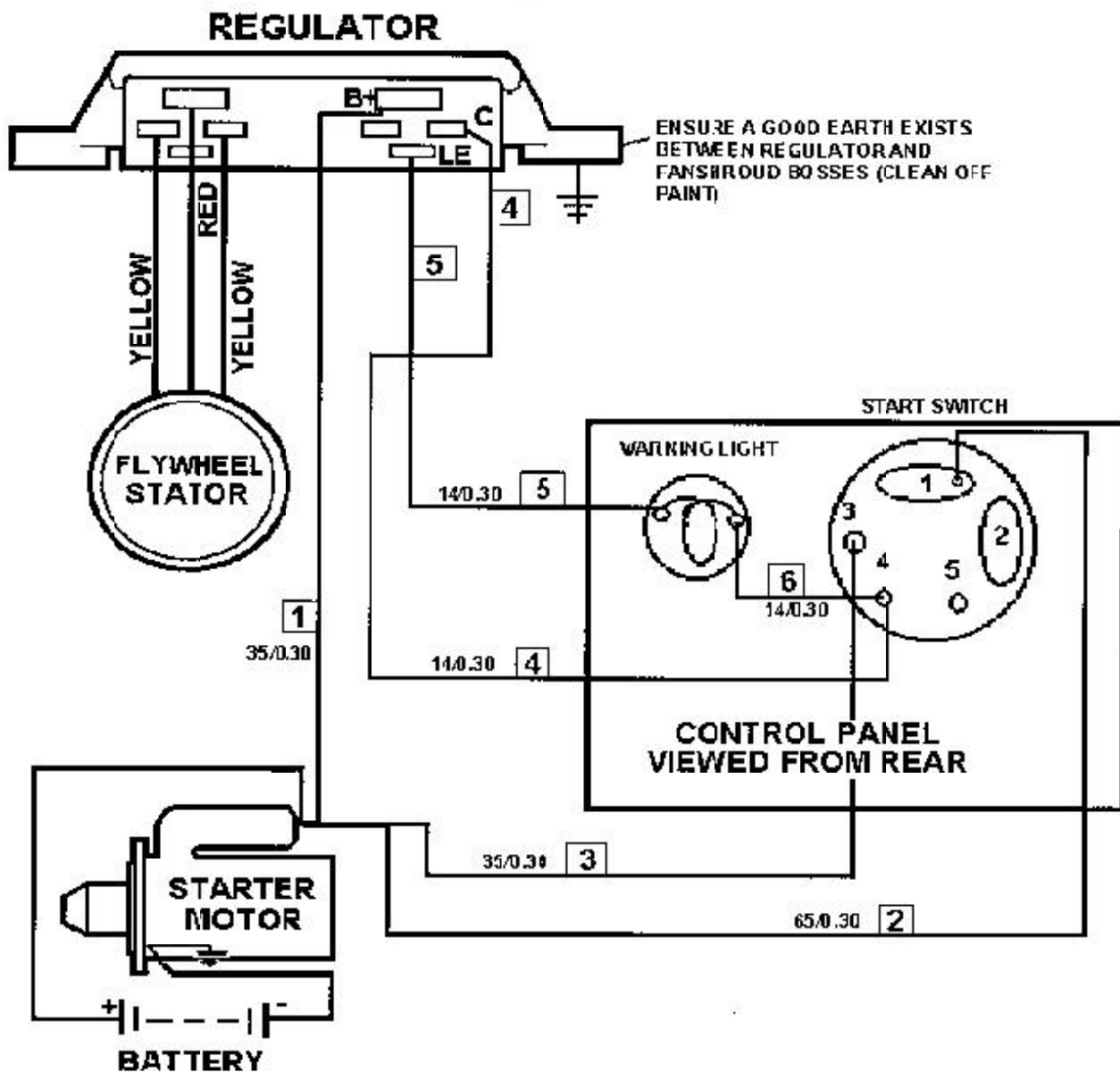

4.6

TECHNICAL INFORMATION

ROAD LIGHTS ELECTRICAL CIRCUIT

4B2000 dumpers from serial number 0863

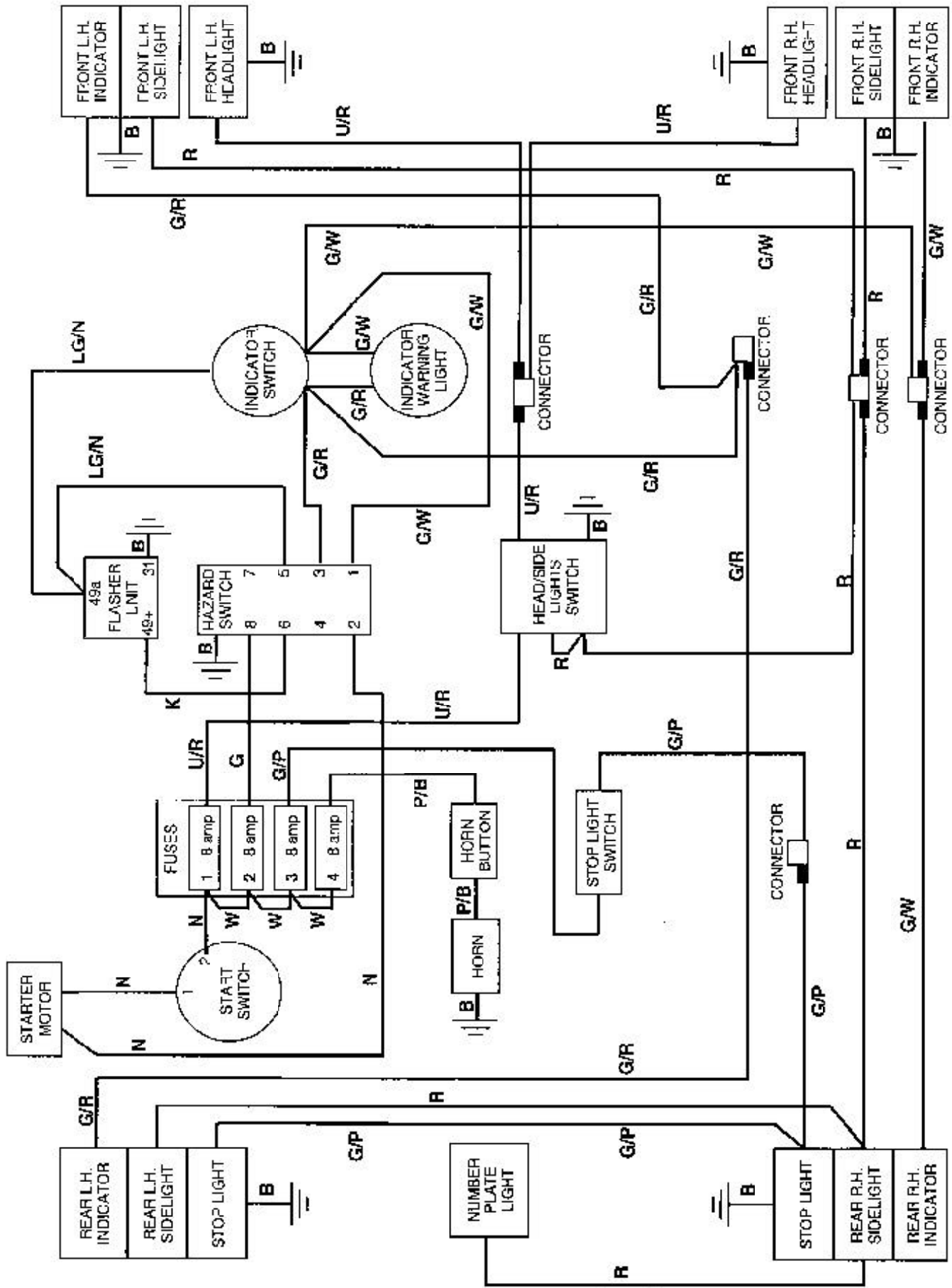

4B2000 DUMPERS

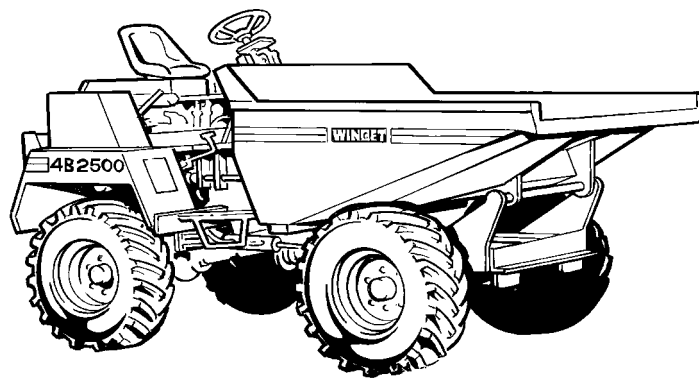

- A CHASSIS & SKIPS**
- B AXLES & STEERING**
- C TRANSMISSIONS**
- D BRAKES**
- E ENGINES**
- F ELECTRICS**
- H HYDRAULICS**
- J DECALS**

Chassis, Panels & Skips

CHASSIS

Non hydraulic rotating skip [A - 1](#)

CHASSIS, front

Hydraulic rotating skip [A - 1A](#)

BATTERY CARRIER [A - 2](#)

SKIPS

Earth & concrete [A - 3](#)

Rotating, manually operated [A - 4](#)

Rotating, hydraulically operated [A - 4A](#)

High discharge [A - 5](#)

PANELS [A - 6](#)

R.O.P.S. FRAME [A - 10](#)

SEAT "KAB" [A - 11](#)

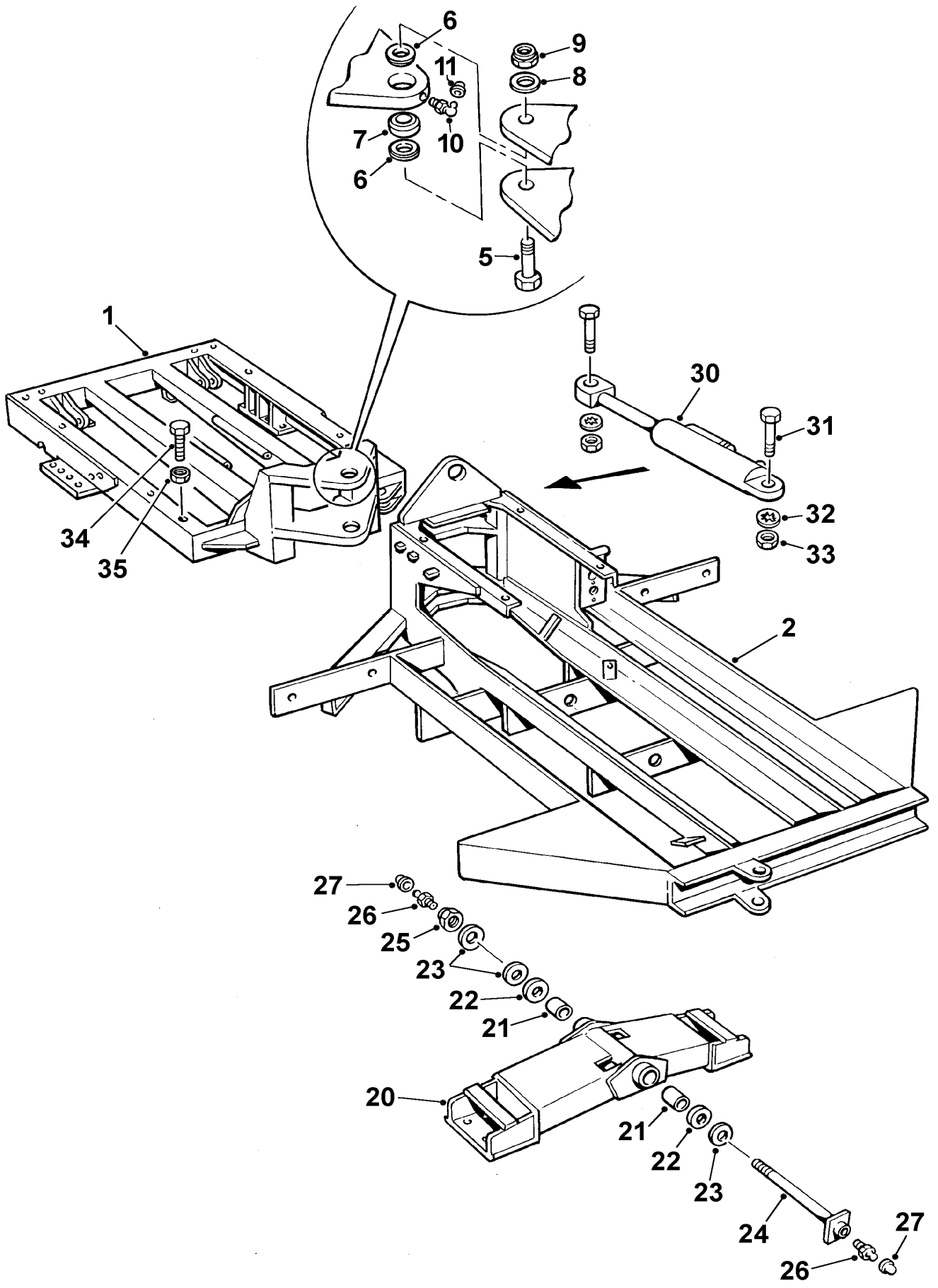

CHASSIS

A - 1

Item	Part no	Serial no	Description	Qty
1	40100A33		CHASSIS, front (to fit Salisbury axle)	1
1	40100A32		CHASSIS, front (to fit Newage axle)	1
2	40101A05		CHASSIS, rear (to fit Salisbury axle)	1
2	40101A06		CHASSIS, rear (to fit Newage axle)	1
5	10375A07		BOLT	2
6	10609A02		SPACER, tapered	4
7	460214		BEARING	2
8	10S43		WASHER	2
9	107S11		NUT	2
10	131S02		NIPPLE, grease	2
11	176S01		CAP, grease nipple	2
20	30188A05	/ 1092	FRAME, axle pivot	1
20	30188A06	1093 /	FRAME, axle pivot	1
21	10938A01		BUSH	2
22	43529C		WASHER, centre, 'bronze'	2
23	ASE178		WASHER, thrust	4
24	20161A07		PIN, pivot	1
25	107S23		NUT, self-locking	1
26	131S03	/ 0745	NIPPLE, grease, push-in	2
26	131S01	0746 /	NIPPLE, grease, threaded	2
27	176S01		CAP, grease nipple	2
30		RAM, steering (see Hydraulic Section)	1
31	10599A01		BOLT, steering ram	2
32	67S13		WASHER	2
33	10600A01		NUT, steering ram	2
34	11S07P		BOLT, skip stop	2
35	7S07		NUT	2

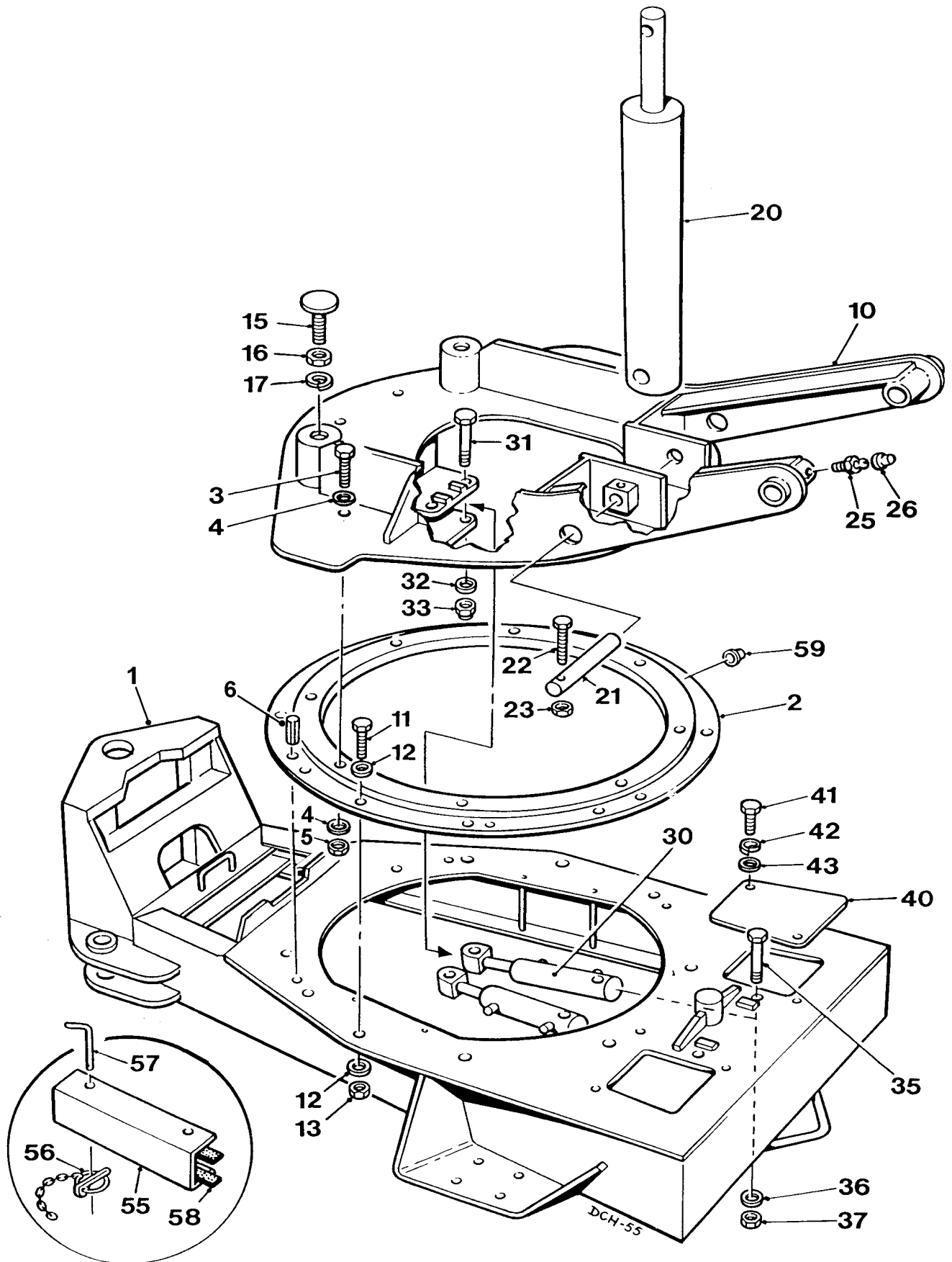

CHASSIS, Hydraulic rotating skip

A - 1A

Item	Part no	Serial no	Description	Qty
1	V2004770		CHASSIS, front, rotating skip	1
2	10640A03		RING, bearing	1
3	11S05E		SCREW, set	8
4	267S07		WASHER, flat	16
5	61S05		NUT, "Binx", self-locking	8
6	54S08J		PIN, roll	4
10	V2004145		FRAME, rotating	1
11	11S05E		SCREW, set	6
11A	11S05F		SCREW, set (<i>not illustrated</i>)	4
12	267S07		WASHER, flat	16
13	61S05		NUT, "Binx", self-locking	10
15	V2004234		SCREW, skip stop	2
16	7S08		NUT	2
17	17S11		WASHER, spring	2
20	30113A06		RAM, tipping	1
21	10720A02		Pin, ram base pivot	2
22	11S03M		SCREW, set	2
23	61S03		NUT, "Binx", self-locking	2
25	131S01		NIPPLE, grease	2
26	176S01		CAP, grease nipple	2
30	30287A03		RAM, rotating	2
31	6S07MM		BOLT, (rotating ram eye)	2
32	10S06		WASHER, flat	6
33	107S18		NUT, "Nyloc" self-locking	2
35	6S07V		BOLT, (rotating ram base)	2
36	10S06		WASHER, flat	6
37	107S18		NUT, "Nyloc", self-locking	2
40	V2004494		COVER	2
41	11S03B		SCREW, set	4
42	17S04		WASHER, spring	4
43	267S05		WASHER, flat	4
55	V2004212		SAFETY SUPPORT, tip ram	1
56	902S02		PIN, lynch, c/w chain	2
57	V2004217		PIN	2
58	106209000		SEAL, strip, (<i>2 meters</i>)	1
59	176S01		CAP, grease nipple	

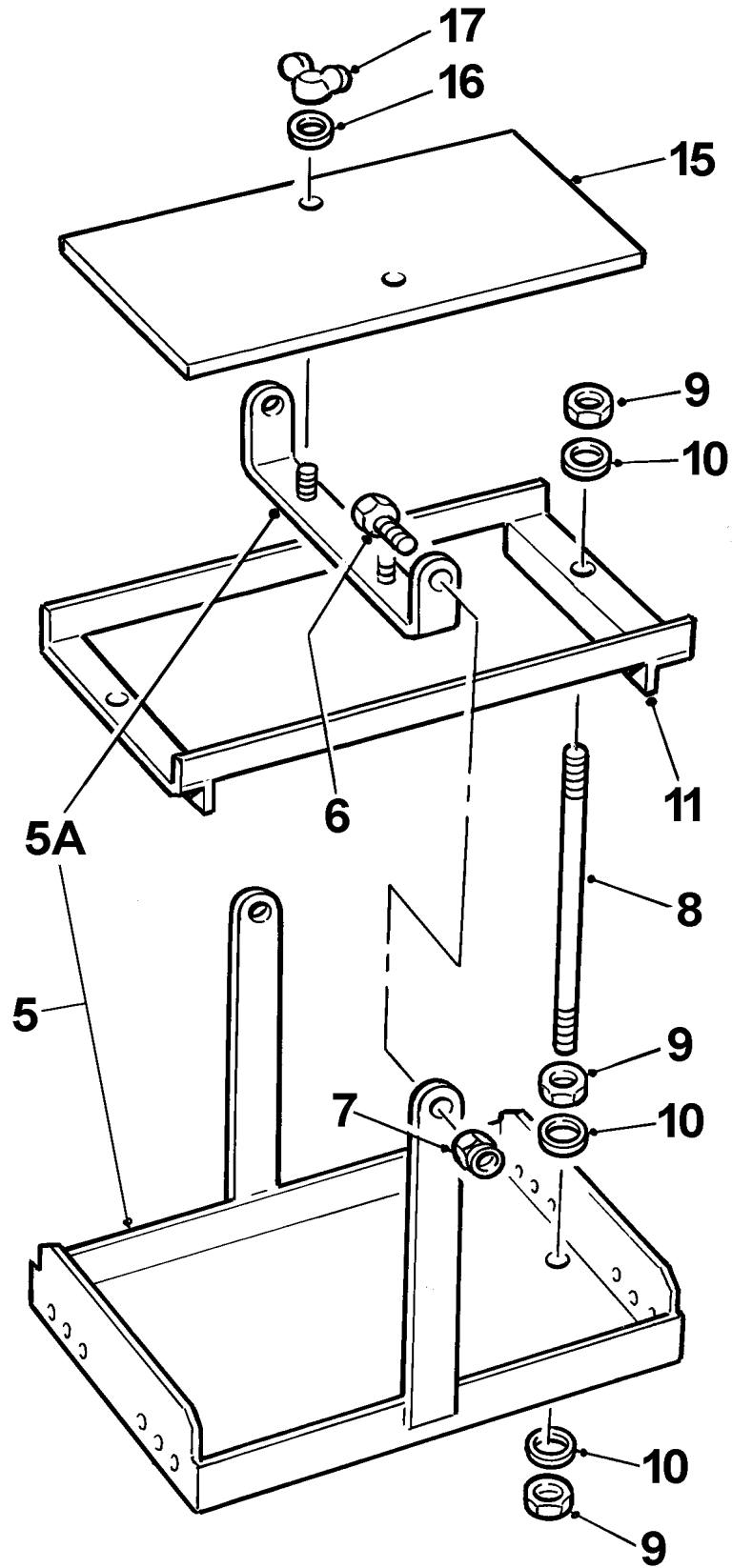

BATTERY CARRIER**A - 2**

Item	Part no	Serial no	Description	Qty
5	30080A03		CARRIER, battery	1
5A	30080A0303		BAR, locking	1
6	11S04C		SCREW, set	2
7	59S03		NUT, 'Nyloc' self-locking	2
8	40SA17		TIE BAR	2
9	9S01		NUT	6
10	267S04		WASHER, flat	6
11	10559A01		CLAMP, battery	1
15	10742A05		COVER, battery	1
16	267S04		WASHER, flat	2
17	177S03		NUT, wing	2

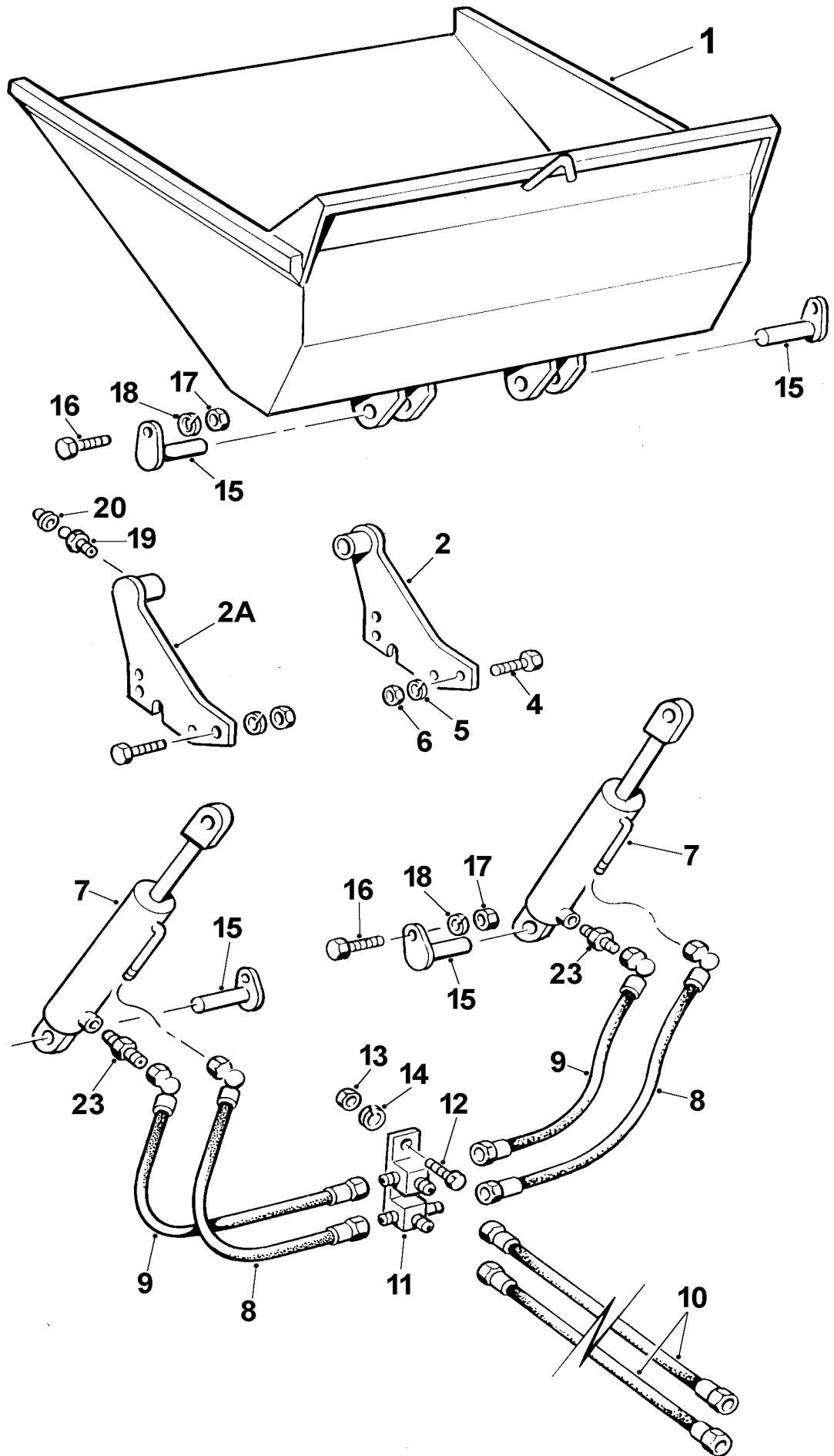

Item	Part no	Serial no	Description	Qty
1	40089A04		SKIP, concrete, 0.96 m ³	1
1	40275A02		SKIP, earth, 0.85 m ³	1
2	30126A10		BRACKET, R.H., skip support	1
2A	30126A11		BRACKET, L.H., skip support	1
4	8S06G		BOLT	8
5	267S09		WASHER, flat	8
6	59S11		NUT, self-locking	8
7	-----		RAM, skip tip (see pages H-6 & H-6A)	2
8	33S02H		HOSE, 470mm long	2
8	33S02J		HOSE, 570mm long, ram retract	2
9	31S02GG		HOSE, bracket to ram extend	2
10	35S02AG		HOSE, bulkhead to bracket	2
11	435388		BRACKET, Tee pieces	1
12	11S02C		BOLT	1
13	7S02		NUT	1
14	17S03		WASHER, spring	1
15	10470A02		PIN, pivot	4
16	11S04E		SCREW, set	4
17	7S04		NUT	4
18	17S05		WASHER, spring	4
19	131S03	/ 0745	NIPPLE, grease, <i>push-in</i>	2
19	131S01	0746 /	NIPPLE, grease, <i>threaded</i>	2
20	176S01		CAP, grease nipple	2
23	122S03		FITTING, adaptor	2

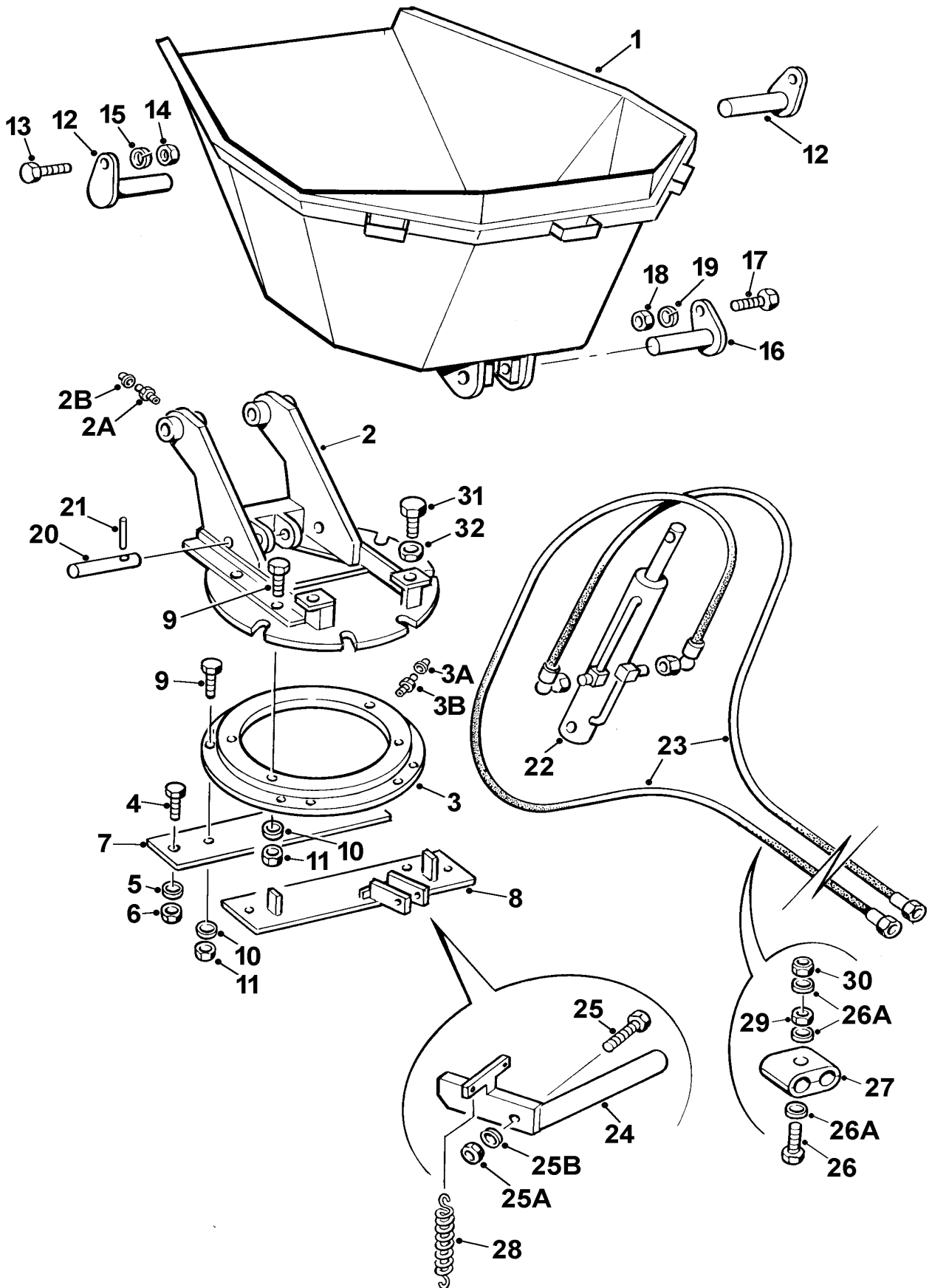

Item	Part no	Serial no	Description	Qty
.....	40312A01		SKIP, 508mm mouth, asembly	
.....	40312A02		SKIP, 1067mm mouth, asembly	
1	40217A01		SKIP, 508mm mouth	1
1	40217A02		SKIP, 1067mm mouth	1
2	40116A03		FRAME, skip	1
2A	131S01		NIPPLE, grease	2
2B	176S01		CAP, grease nipple	2
3	10640A02		RING, slewing turntable	1
3A	176S01		CAP, grease nipple	4
3B		NIPPLE, grease	4
4	8S05D		BOLT	4
5	267S07		WASHER, flat	8
6	59S04		NUT, nylon insert	4
7	10833A04		PLATE, front mount	1
8	30306A01		PLATE, rear mount	1
9	8S05E		BOLT	4
10	267S07		WASHER, flat	8
11	59S04		NUT, nylon insert	4
12	10522A04		PIN, skip pivot	2
13	11S04C		SCREW, set	2
14	7S04		NUT	2
15	17S05		WASHER, spring	2
16	10919A01		PIN, ram upper pivot	1
17	11S04C		SCREW, set	1
18	7S04		NUT	1
19	17S05		WASHER, spring	1
20	10720A02		PIN, ram lower pivot	1
21	55S07Q		PIN, tension	1
22		RAM, hyd (see Hydraulics Section)	1
23	31S02K		HOSE, ram to bulkhead	2
24	40296A03		CATCH, skip locking	1
25	8S05H		BOLT	1
25A	59S04		NUT, 'Nyloc' self-locking	1
25B	267S07		WASHER, flat	1
26	11S02H		SCREW, set	1
26A	267S04		WASHER, flat	3
27	187S08JJ		CLAMP, hose	1 pair
28	C173D		SPRING, skip catch	2
29	7S02		NUT	1
30	61S02		NUT, 'Binx' self locking	1
31	11S07P		SCREW, set	2
32	7S07		NUT	2
.....	V2003111		TIE, nylon (<i>not illustrated</i>)	2
.....	V2003253		TIE, nylon (<i>not illustrated</i>)	1

A - 4A

4B2000 Dumper

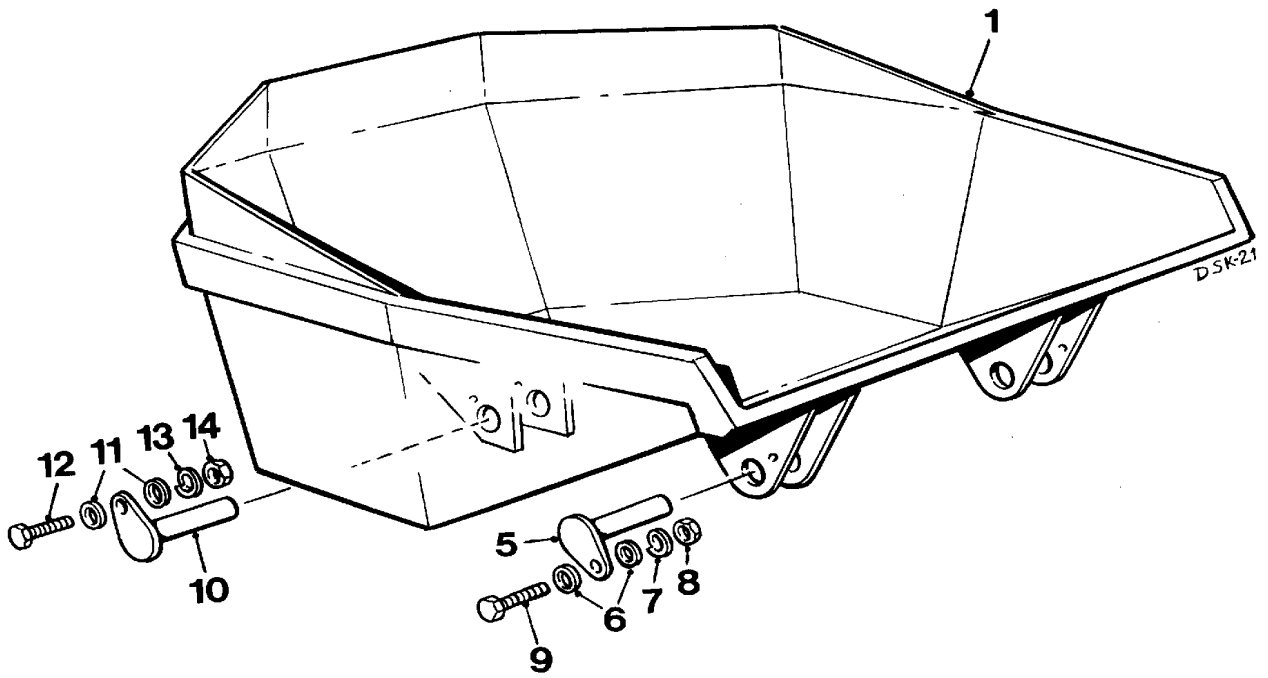

SKIP, Hydraulic rotating**A - 4A**

Item	Part no	Serial no	Description	Qty
1	V2004449		SKIP, rotating, hydraulically swivelled	1
5	10522A04		PIN, skip pivot	2
6	267S06		WASHER, flat	4
7	17S05		WASHER, spring	2
8	7S04		NUT	2
9	11S04C		SCREW, set	2
10	10919A01		PIN, ram pivot	1
11	267S06		WASHER, flat	2
12	11S04C		SCREW, set	1
13	17S05		WASHER, spring	1
14	7S04		NUT	1

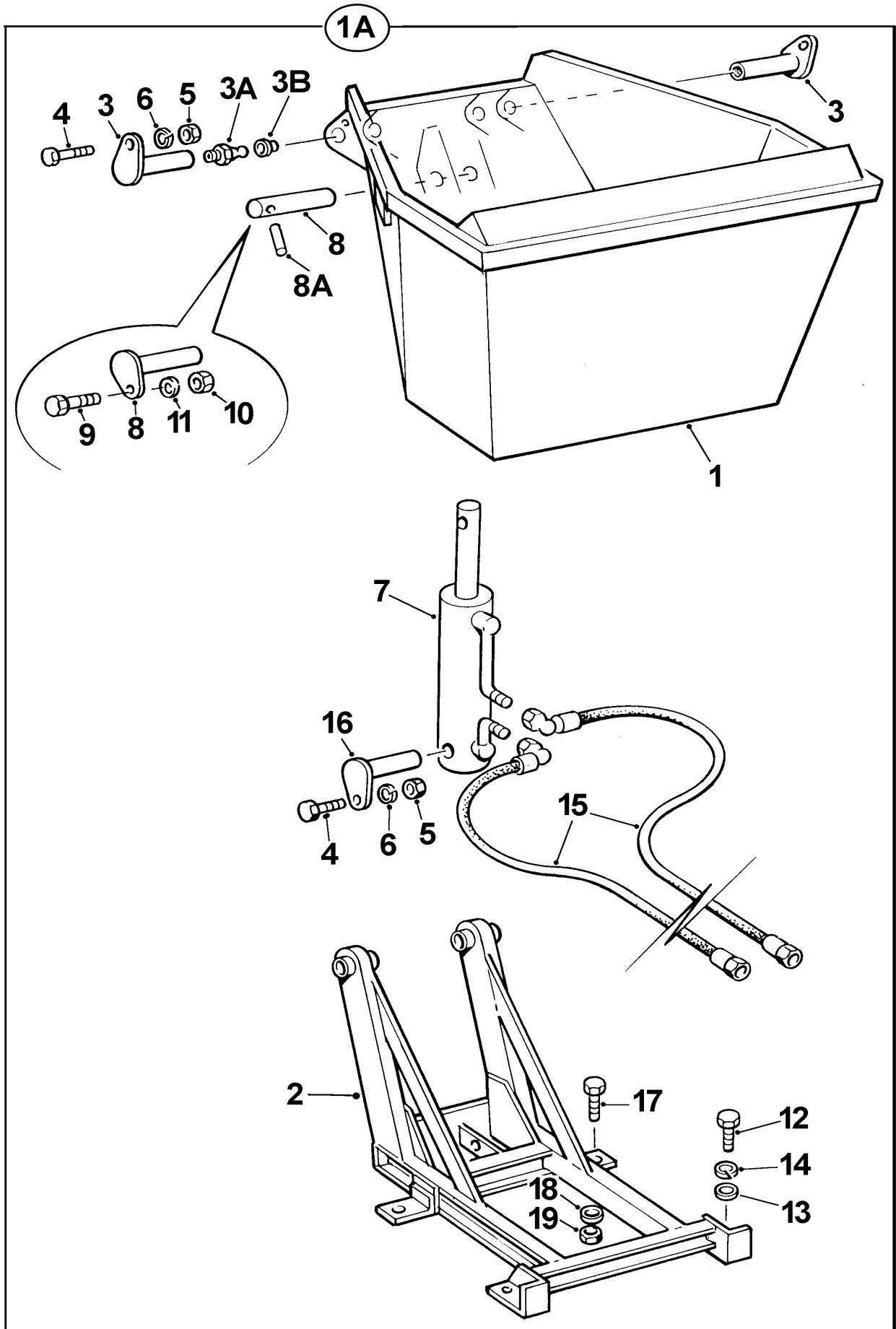

SKIP, high discharge

Item	Part no	Serial no	Description	Qty
1A	40313A01		SKIP, high discharge, assembly	1
1	40299A01		SKIP, high discharge	1
2	40252A02		FRAME	1
3	10932A01		PIN, skip pivot	2
3A	131S01		NIPPLE, grease	2
3B	176S01		CAP, grease nipple	2
4	11S04C		SCREW, set	3
5	7S04		NUT	3
6	17S05		WASHER, spring	3
7		RAM, hyd (<i>see Hydraulics Section</i>)	1
8	10919A02	/ July 90	PIN, ram upper pivot	1
8	10919A04	July 90 /	PIN, ram upper pivot	1
8A	55S07T	July 90 /	PIN, spirol	1
9	11S03C		SCREW, set	2
10	7S03		NUT	2
11	17S04		WASHER, spring	2
12	11S07K		SCREW, set	4
13	267S10		WASHER, flat	4
14	17S09		WASHER, spring	4
15	31S02P		HOSE, bulkhead to ram	2
16	10919A03		PIN, ram lower pivot	1
17	11S05F		SCREW, set	2
18	267S07		WASHER, flat	2
19	59S04		NUT, 'Nyloc' self-locking	2

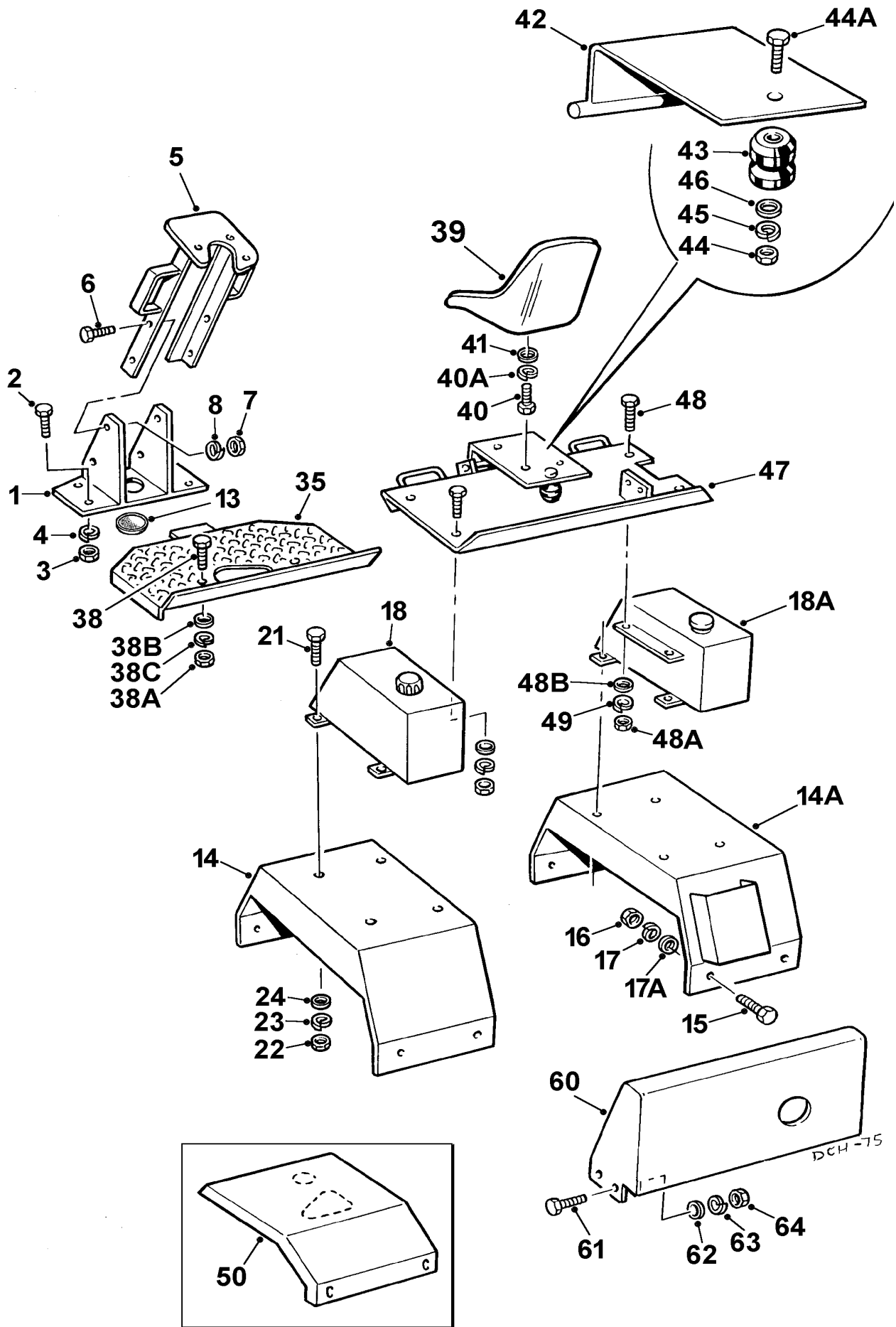

PANELS

Item	Part no	Serial no	Description	Qty
1	30184A02		PLATE, mounting	1
2	11S04C		SCREW, set	4
3	7S04		NUT	4
4	17S05		WASHER, spring	4
5	30125A02		SUPPORT, steering column	1
6	11S04C		SCREW, set	4
7	7S04		NUT	4
8	17S05		WASHER, spring	4
13	435375		GROMMET	1
14	40280A11		MUDWING, L.H.	1
14A	40279A04		MUDWING, R.H.	1
15	11S04C		SCREW, set	8
16	7S04		NUT	8
17	17S05		WASHER, spring	8
17A	267S06		WASHER, flat	8
18	40282A04		TANK, hydraulic (<i>see page H - 1</i>)	1
18A		TANK, fuel (<i>see page E - 1A</i>)	1
21	11S04C		SCREW, set	8
22	7S04		NUT	8
23	17S05		WASHER, spring	8
24	267S06		WASHER, flat	8
35	30163A06		PLATE, floor	1
38	11S04C		SCREW, set	2
38A	7S04		NUT	2
38B	267S06		WASHER, flat	2
38C	17S05		WASHER, spring	2
39	20072A01		SEAT (<i>OBSOLETE: use V2000954</i>)	
39	V2000954		SEAT	1
<p>NOTE: When replacing seat 20072A01 with V2000954, refer to Bulletin SB2 (August 1991) for fitting instructions.</p>				
40	11S03B		SCREW, set	4
40A	17S04		WASHER, spring	4
41	267S05		WASHER, flat	4

4B2000 Dumper

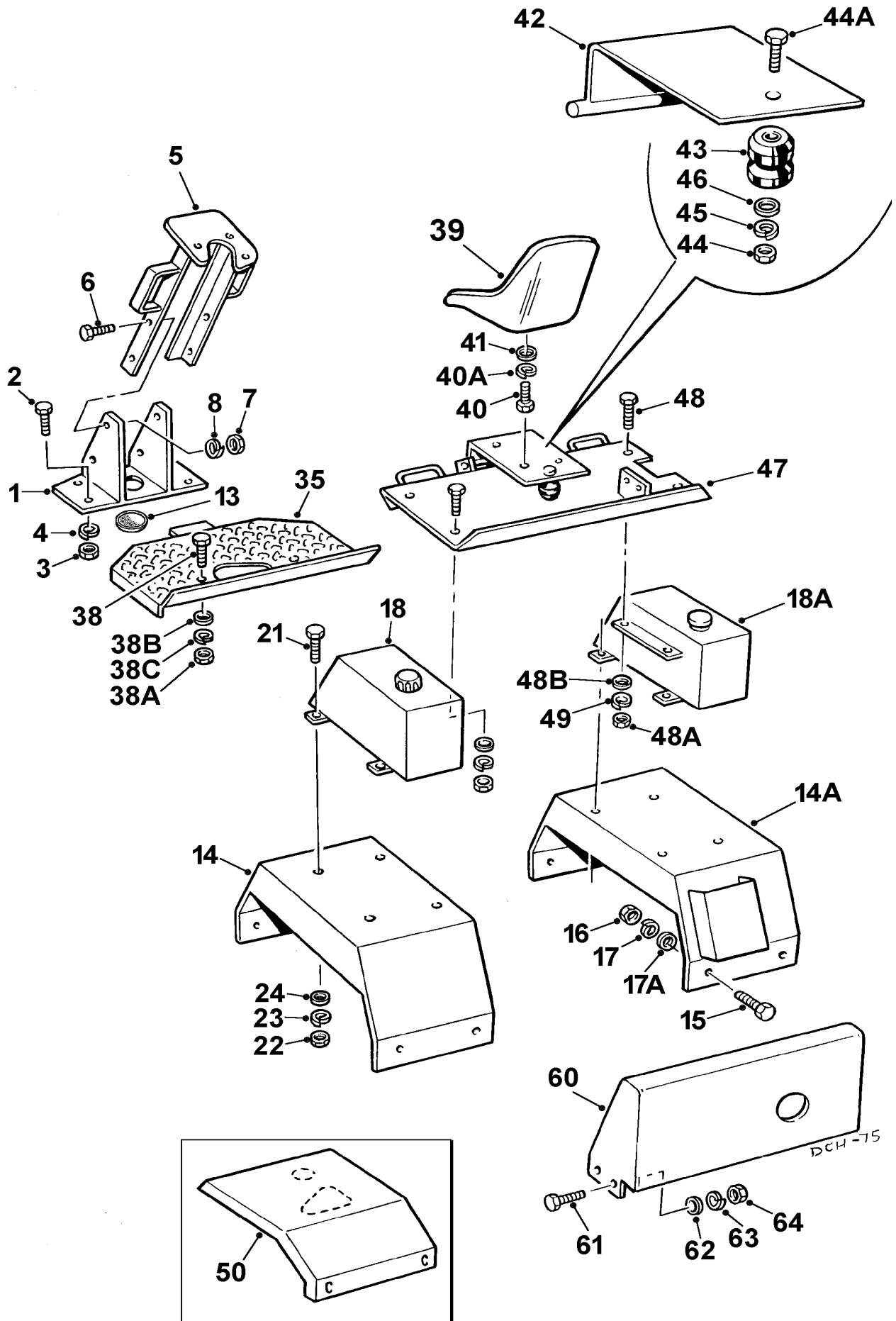

PANELS

Item	Part no	Serial no	Description	Qty
42	30148A06		FRAME, seat	1
43	10519A01		SPRING, rubber	1
44	7S04		NUT	1
44A	206S03C		SCREW, counter sunk	1
45	17S05		WASHER, spring	1
46	C180B		WASHER, flat	1
47	30025A09	/ Jan-88	PLATE, seat support	1
47	30025A19	Jan-88 /	PLATE, seat support	1
48	11S04C		SCREW, set	4
48A	7S04		NUT	4
48B	267S06		WASHER, flat	4
49	17S05		WASHER, spring	4
50	30063A03		COVER, engine	1
.....	11S04C		# SCREW, set	4
.....	7S04		# NUT	4
.....	17S05		# WASHER, spring	4
.....	267S06		# WASHER, flat	4
			# <i>Fittings to retain engine cover (item 50)</i>	
60	40105A12		COVER, rear, TS2 & TR2, P600/2	1
60	40105A03		COVER, rear, PH2	1
60	40105A08		COVER, rear, PH2 with air cleaner	1
60	40105A05		COVER, rear, ST2	1
61	11S04C		SCREW, set	4
62	267S06		WASHER, flat	4
63	17S05		WASHER, spring	4
64	7S04		NUT	4

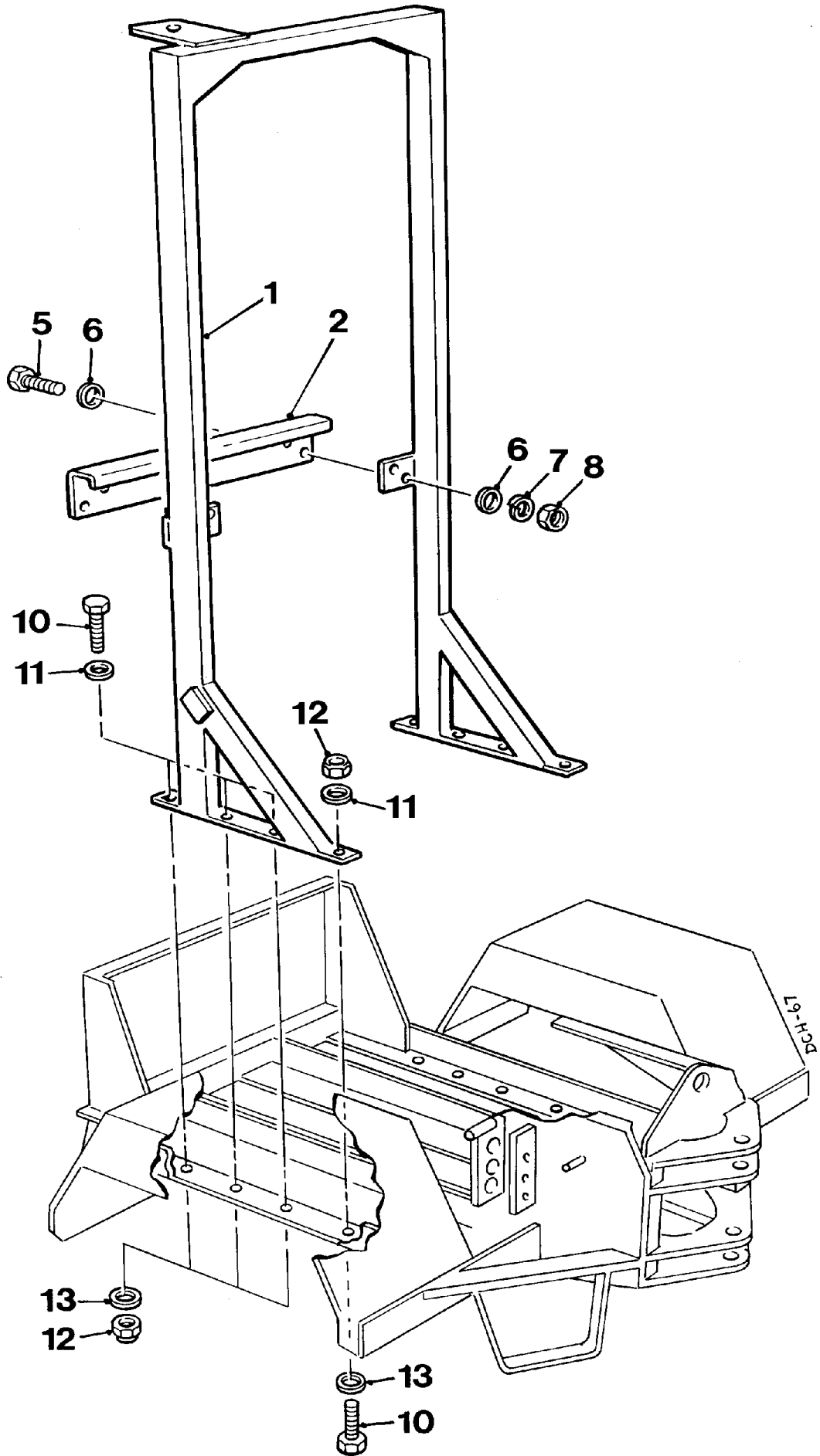

Item	Part no	Serial no	Description	Qty
Machines with Lister-Petter TS2 & TR2 engines				
.....	V602753		ROPS KIT, includes items 1 to 15 listed below. <i>Plus.....</i> Seat assembly KAB XH2/P2N to ISO 6683 V2005013 (see page A - 11). TS/TR exhaust silencer kit V602755 (see page E - 3A)	
Machines with Lister-Petter PH2, P600 & ST2 engines				
.....	V602754		ROPS KIT, includes items 1 to 15 listed below. <i>Plus.....</i> Seat assembly KAB XH2/P2N to ISO 6683 V2005013 (see page A - 11).	
1	V2005004	May-99 /	FRAME (ROPS) c/w stiffener, assy	1
2	V2005011		STIFFENER	1
3	V2004754		DECAL, damage (<i>not illustrated</i>)	1
5	11S04C		SCREW, set	4
6	267S06		WASHER, flat	8
7	17S05		WASHER, spring	4
8	7S04		NUT	4
10	11S13H		SCREW, set	8
11	V2003892		WASHER, special	8
12	59S15		NUT, Nyloc	8
13	267S08		WASHER, flat	8
14	V2005030		PLATE, R.O.P.S. ident. (<i>not illustrated</i>)	
15	101S05D		RIVET, pop (<i>not illustrated</i>)	4

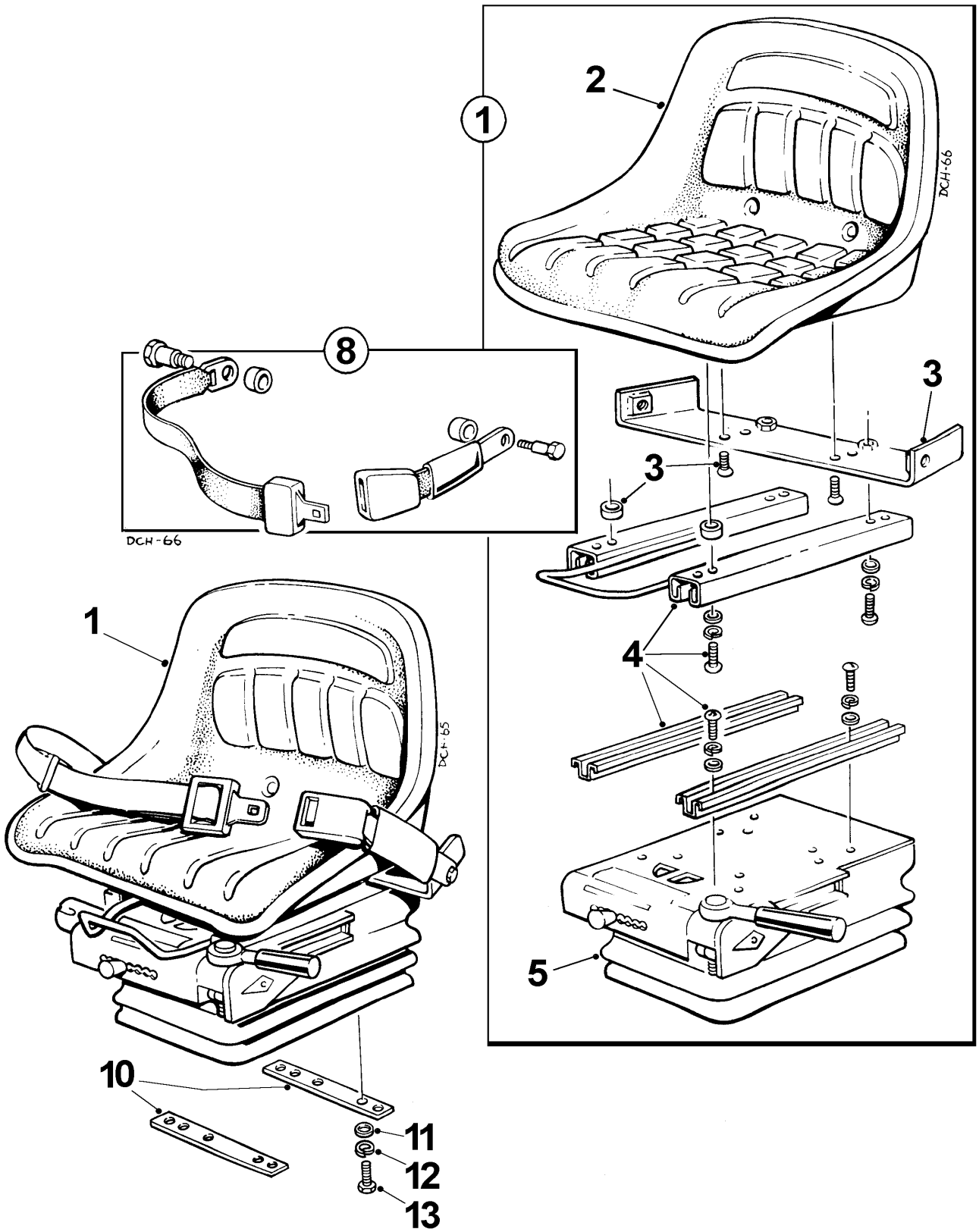

SEAT, assembly
KAB XH2/P2N' to ISO 6683

A - 11

Item	Part no	Serial no	Description	Qty
<p>This seat assembly is used with and is included with R.O.P.S. kits..... V602753 (see page A - 10) V602754 (see page A - 10) V602755 (see page E - 3A)</p> <p><i>All 4B2000 dumpers which are fitted with a R.O.P.S. (Roll Over Protective Structure) including 'Export' models must be fitted with this seat assembly.</i></p> <p><i>Earlier versions of the KAB seating XL or XH suspension unit do not meet the requirements of the ISO 6683 (Seat Belt Pull Test) and should not be used in conjunction with a R.O.P.S.</i></p>				
1	V2005013	May-99 /	SEAT, assembly c/w with seat belt	1
2	V2000954		SEAT, 'KAB P2N'	
3	V602750		BRACKET, anchorage	1
4	V602752		SLIDE RAIL, assembly	1
5	V602751		UNIT, suspension 'XH2' (ISO 6683)	1
8	V602749		BELT, seat	1
10	V2004206		PLATE, clamp	2
11	267S05		WASHER, flat	4
12	17S04		WASHER, spring	4
13	11S03C		SCREW, set	4

Axles

WHEELS & TYRES **B - 1**

STEERING COLUMN **B - 2**

AXLES, Salisbury

Dry disc brakes **B - 5**

Non braked **B - 6**

Oil immersed brakes **B - 7**

AXLES, Newage

Axle identification: *Up to serial no. 1092* **B - 7A**

Axle identification: *From serial no. 1093* **B - 7B**

200RF with brakes: *Up to serial no. 1092* **B - 8**

175RF without brakes: *Up to ser. no. 1092* **B - 9**

212 without brakes: *From serial no. 1093*

Input Pinion & Differential **B - 10**

Planet Carrier & Axle Casing **B - 10A**

Hub & Axle Shaft **B - 10B**

215 with brakes: *From serial no. 1093*

Input Pinion & Differential **B - 11**

Planet Carrier & Axle Casing **B - 11A**

Hub & Axle Shaft **B - 11B**

Brakes **B - 11C**

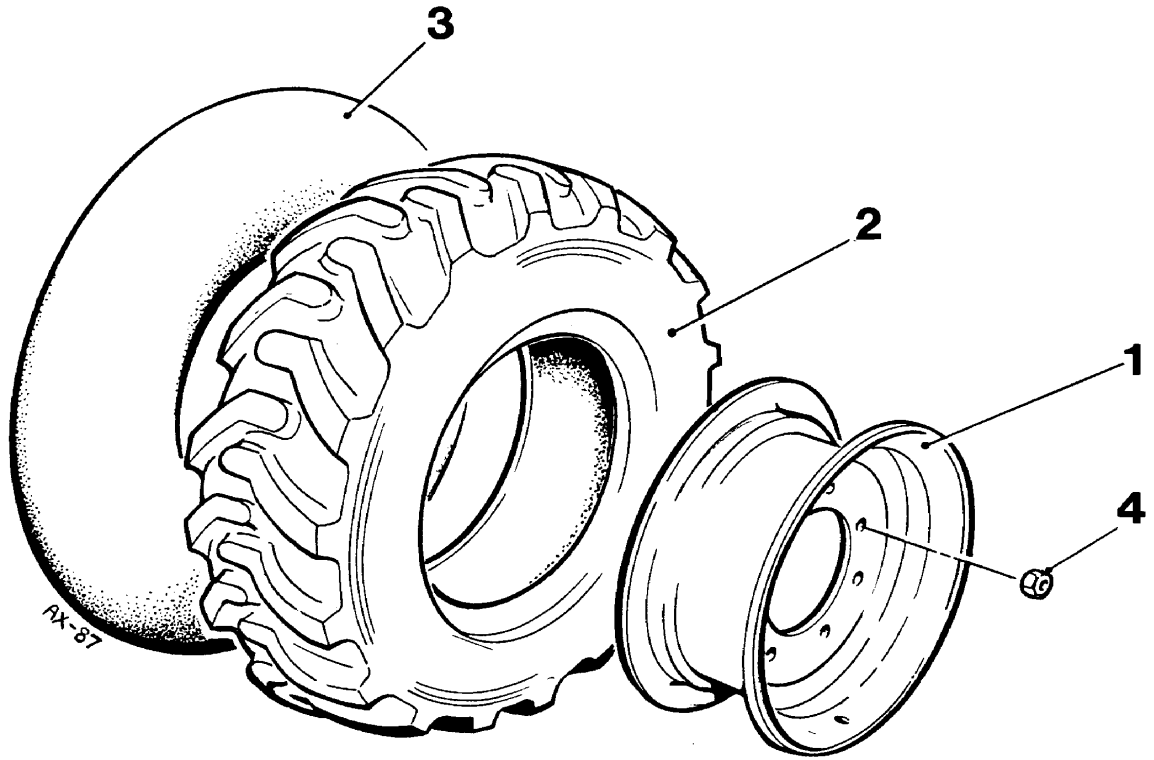

Item	Part no	Serial no	Description	Qty
------	---------	-----------	-------------	-----

Wheels suitable for all types of axle.

-	24S25		WHEEL ASSEMBLY, L.H.	2
-	24S26		WHEEL ASSEMBLY, R.H.	2
1	30192A03		RIM, 5.5 x 16	1
2	20S08		TYRE, 7.5 x 16	1
3	23S03		TUBE, 7.5 x 16	1
4	10668A01		NUT, wheel	20

Wheels suitable for all types of axle, except for Salisbury dry disc and non braked.

-	24S29		WHEEL ASSEMBLY, L.H.	2
-	24S30		WHEEL ASSEMBLY, R.H.	2
1	20131A03		RIM, 7 x 15	1
2	20S17		TYRE, 10/75 x 15	1
3	23S11		TUBE, 10 x 15	1
4	10668A01		NUT, wheel	20

-	24S05		WHEEL ASSEMBLY, L.H.	2
-	24S06		WHEEL ASSEMBLY, R.H.	2
1	20131A02		RIM, 9 x 15	1
2	20S13		TYRE, 11.5/80 x 15	1
3	23S08		TUBE, 11.5 x 15	1
4	10668A01		NUT, wheel	20

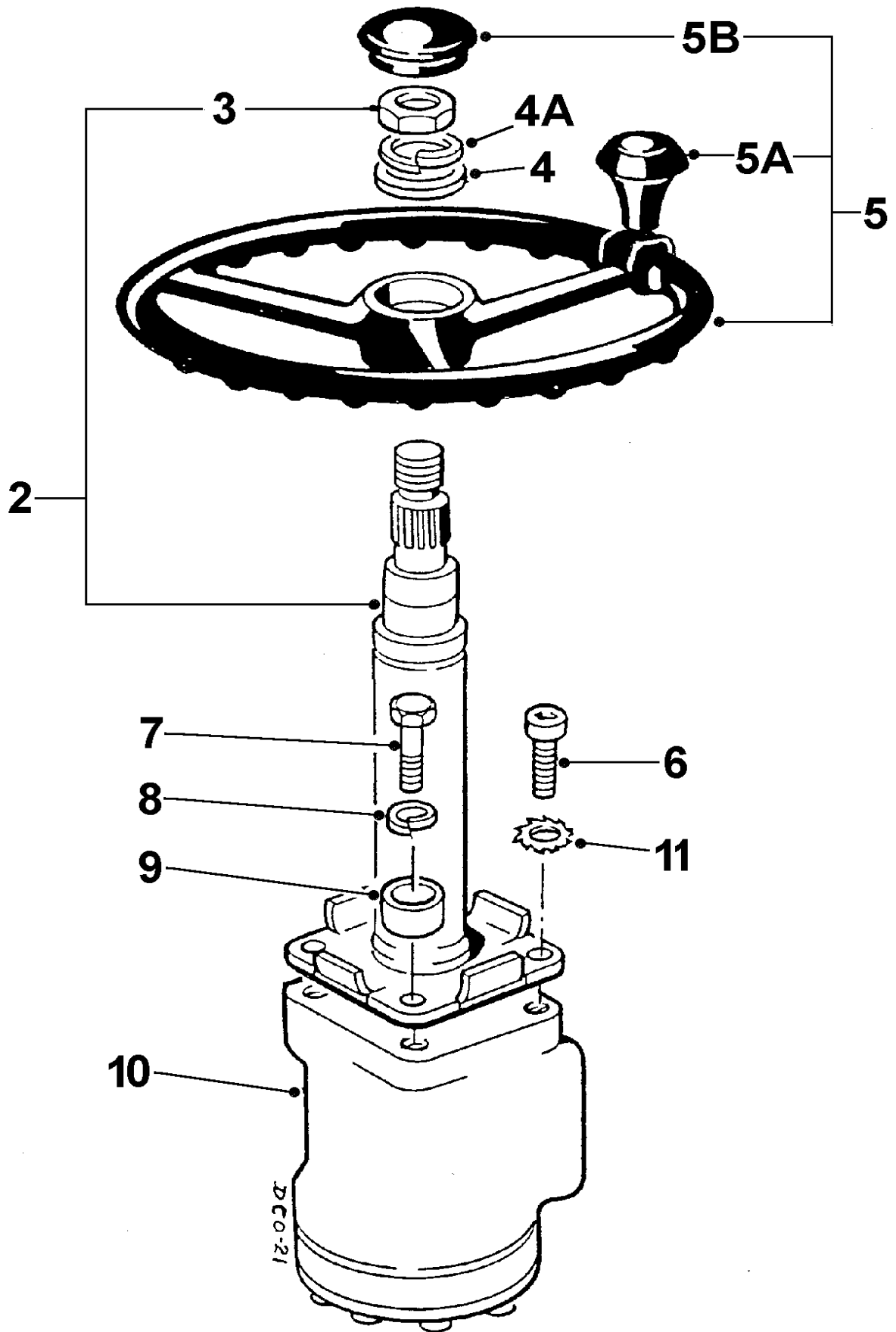

STEERING COLUMN

B - 2

Item	Part no	Serial no	Description	Qty
2	CSE1781		COLUMN, steering assembly	1
3	95S06		# NUT (5/8" UNF)	1
3		# NUT (M16 x 1.5 pitch) # <i>Check thread before ordering nut</i>	1
4	267S09		WASHER, flat	1
4A	17S08		WASHER, spring	1
5	40064A01		WHEEL, steering, 400mm dia (OBSOLETE: use V2002350)	1
5B	10314A01		CAP	1
5	V2002350		WHEEL, steering, 400mm dia	1
5B	V601232		CAP	1
.....	V601233		REDUCER, cap	1
5	V2003164		WHEEL, steering, 350mm dia , c/w knob (OBSOLETE: use V2004152)	1
5B	V601232		CAP	1
5	V2004152		WHEEL, steering, 350mm dia	1
5A	V600491		SPINNER, knob	1
5B	V2004153		CAP	1
6	103S04B		SCREW, socket	2
7	69S03G		BOLT	2
8	41S05		WASHER, spring	2
9	CSE182		SPACER	2
10	CSE1782		UNIT, steering, EM&S <i>(No load sensing. Not used with hydraulic rotating skips)</i>	1
.....	V602683		KIT, seals, EM&S	AR
10	V2003312		UNIT, steering <i>(With load sensing. Used with hydraulic rotating skips)</i>	1
11	67S04		WASHER, shakeproof	2

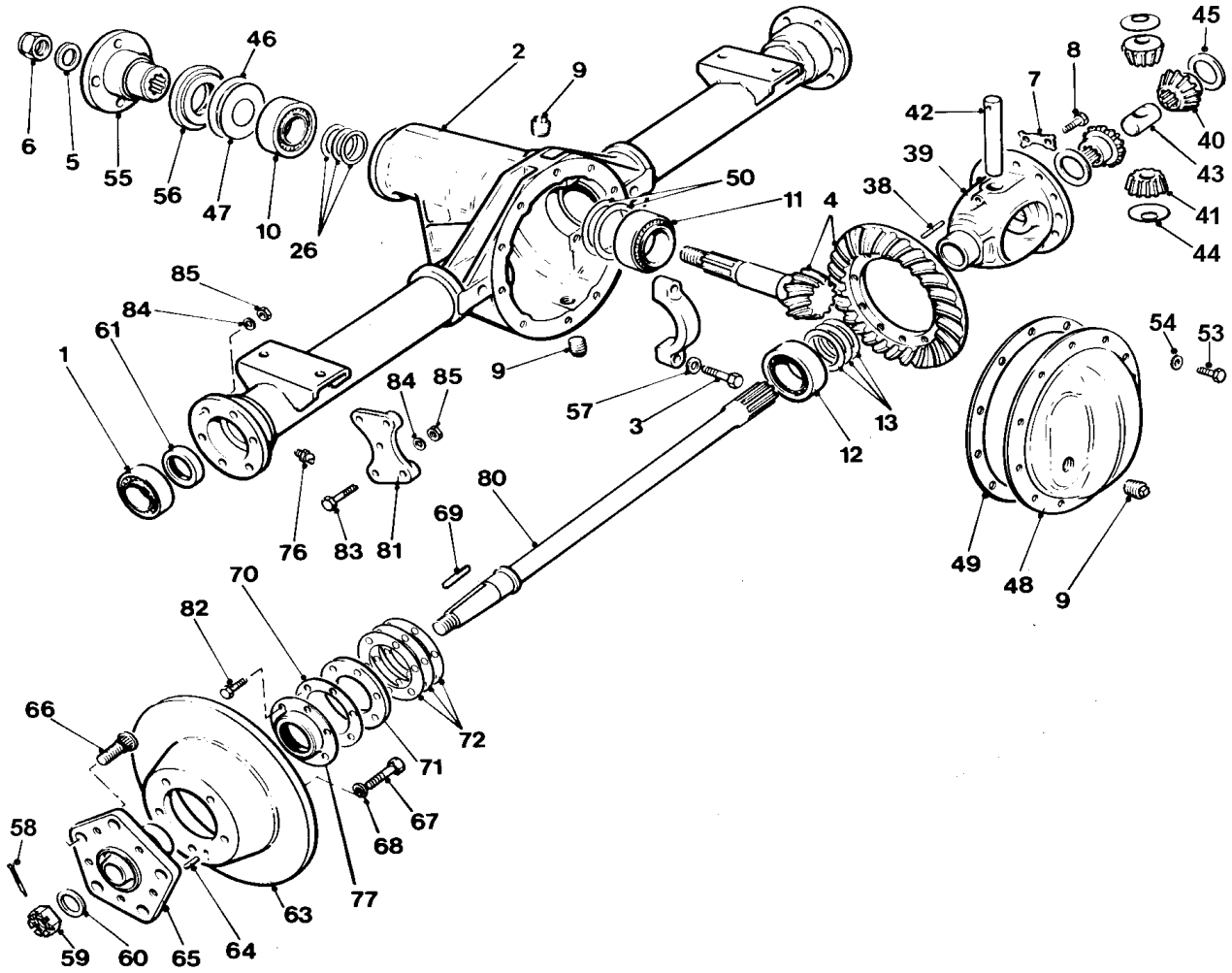

DRIVE AXLE, Salisbury dry disc**B - 5**

Item	Part no	Serial no	Description	Qty
-	30166A01		AXLE, assembly	1
1	30166A0101		BEARING	2
2	30166A0102		CARRIER & TUBE, assembly	1
3	30166A0103		BOLT, diff bearing cap	4
4	30166A0104		GEAR & PINION assembly	1
5	30166A0105		WASHER	1
6	30166A0106		NUT, pinion locking	1
7	30166A0107		NUT, drive gear locking	6
8	30166A0108		BOLT, drive gear	12
9	30166A0109		PLUG, level/filler	3
10	30166A0110		BEARING	1
11	30166A0111		BEARING	1
12	30166A0112		BEARING	2
13	30166A0113		SHIM, diff bearing, 0.028"	AR
13	30166A0114		SHIM, diff bearing, 0.030"	AR
13	30166A0115		SHIM, diff bearing, 0.031"	AR
13	30166A0116		SHIM, diff bearing, 0.032"	AR
13	30166A0117		SHIM, diff bearing, 0.033"	AR
13	30166A0118		SHIM, diff bearing, 0.034"	AR
13	30166A0119		SHIM, diff bearing, 0.035"	AR
13	30166A0120		SHIM, diff bearing, 0.036"	AR
13	30166A0121		SHIM, diff bearing, 0.037"	AR
13	30166A0122		SHIM, diff bearing, 0.038"	AR
13	30166A0123		SHIM, diff bearing, 0.039"	AR
13	30166A0124		SHIM, diff bearing, 0.040"	AR
13	30166A0125		SHIM, diff bearing, 0.045"	AR
26	30166A0126		SHIM, outer pinion bearing, 0.030"	AR
26	30166A0127		SHIM, outer pinion bearing, 0.031"	AR
26	30166A0128		SHIM, outer pinion bearing, 0.032"	AR
26	30166A0129		SHIM, outer pinion bearing, 0.033"	AR
26	30166A0130		SHIM, outer pinion bearing, 0.034"	AR
26	30166A0131		SHIM, outer pinion bearing, 0.035"	AR
26	30166A0132		SHIM, outer pinion bearing, 0.036"	AR
26	30166A0133		SHIM, outer pinion bearing, 0.037"	AR
26	30166A0134		SHIM, outer pinion bearing, 0.038"	AR
26	30166A0135		SHIM, outer pinion bearing, 0.039"	AR
26	30166A0136		SHIM, outer pinion bearing, 0.040"	AR
-	30166A0137		DIFFERENTIAL CASE, assembly	1
38	30166A0138		PIN, roll	1
39	30166A0139		CASE, differential	1
40	30166A0140		GEAR, side, diff	2
41	30166A0141		MATE, diff pinion	2
42	30166A0142		SHAFT, diff pinion mate	1
43	30166A0143		SPACER, axle shaft	1
44	30166A0144		WASHER, thrust	2

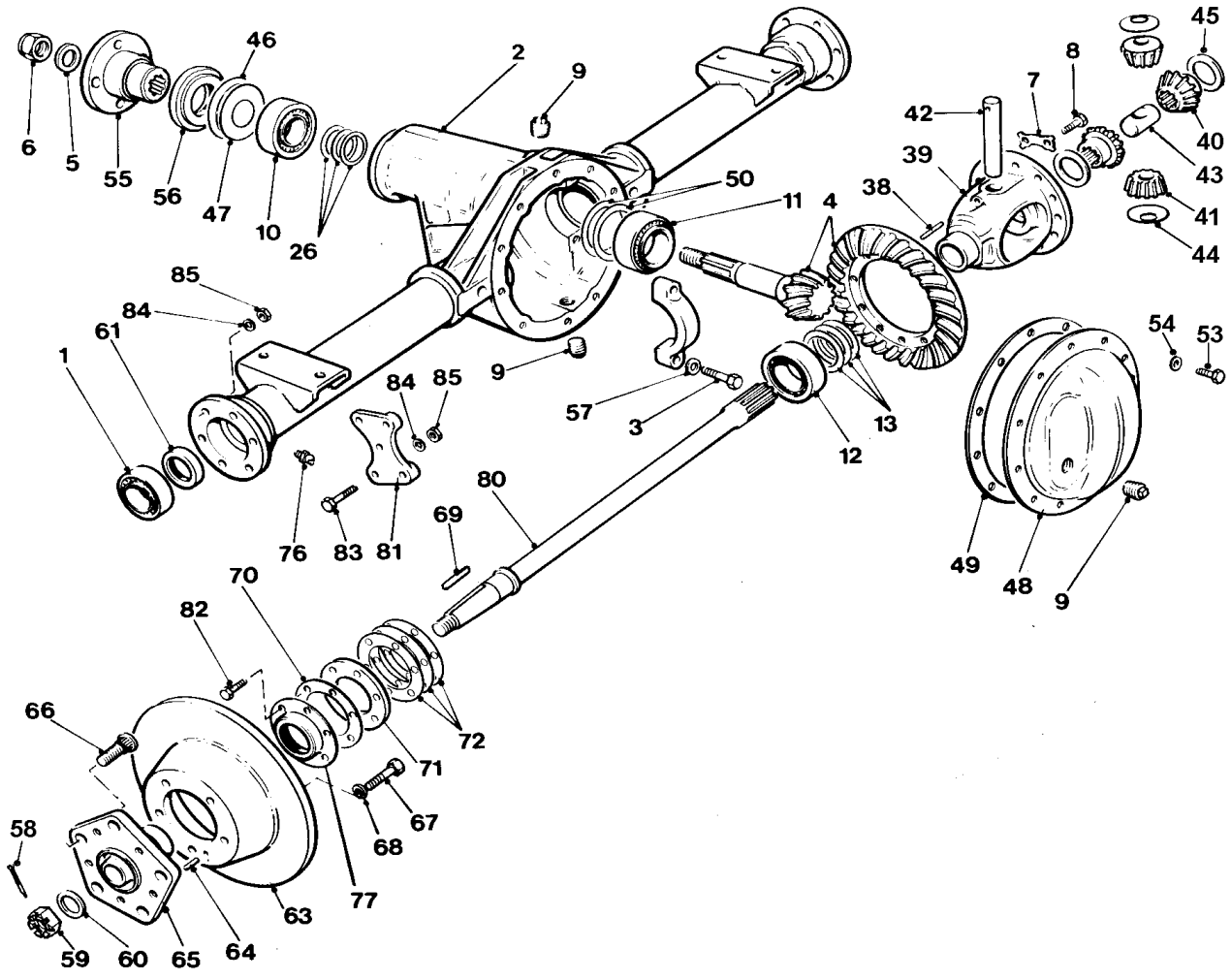

DRIVE AXLE, Salisbury dry disc

B - 5

Item	Part no	Serial no	Description	Qty
45	30166A0145		WASHER, thrust	2
46	30166A0146		GASKET, pinion oil seal	1
47	30166A0147		SLINGER, pinion oil	1
48	30166A0148		COVER, gear carrier	1
49	30166A0149		COVER, gasket	1
50	30166A0150		SHIM, inner pinion bearing, 0.003"	AR
50	30166A0151		SHIM, inner pinion bearing, 0.005"	AR
50	30166A0152		SHIM, inner pinion bearing, 0.010"	AR
53	30166A0153		BOLT, carrier cover	10
54	30166A0154		WASHER, locking	10
55	30166A0155		FLANGE, companion	1
56	30166A0156		SEAL, oil, pinion	1
57	30166A0157		WASHER, locking, diff bearing cap	4
58	30166A0158		PIN, cotter	2
59	30166A0159		NUT, shaft	2
60	30166A0160		WASHER, shaft	2
61	30166A0161		SEAL, oil, axle shaft	2
-	30166A0162		BRAKE, hub & disc assembly	2
63	30166A0163		DISC, brake	2
64	30166A0164		PIN, roll	4
65	30166A0165		HUB & STUD, assembly	1
66	30166A0166		STUD, wheel	10
67	30166A0167		BOLT, brake disc	10
68	30166A0154		WASHER, locking	10
69	30166A0169		KEY, axle shaft	2
70	30166A0170		GASKET, hub oil seal	2
71	30166A0171		PLATE, RETAINER	2
72	30166A0172		SHIM, wheel bearing, 0.003"	AR
72	30166A0173		SHIM, wheel bearing, 0.005"	AR
72	30166A0174		SHIM, wheel bearing, 0.010"	AR
72	30166A0175		SHIM, wheel bearing, 0.030"	AR
76	30166A0176		NIPPLE, grease	2
77	30166A0177		SEAL, oil, hub, assembly	2
77	30166A0178		CONTAINER, oil seal	1
77	30166A0179		SEAL, oil	1
80	30166A0180		SHAFT, axle	2
81	30166A0181		BRACKET, caliper	2
82	30166A0182		BOLT, brake back plate	6
83	30166A0183		BOLT, caliper mounting plate	6
84	30166A0154		WASHER, locking	12
85	30166A0185		NUT, brake back plate	12
-	6S05C	Axle fixings	BOLT	4
-	132S05	(not illustrated)	NUT	4
-	10S04		WASHER	4

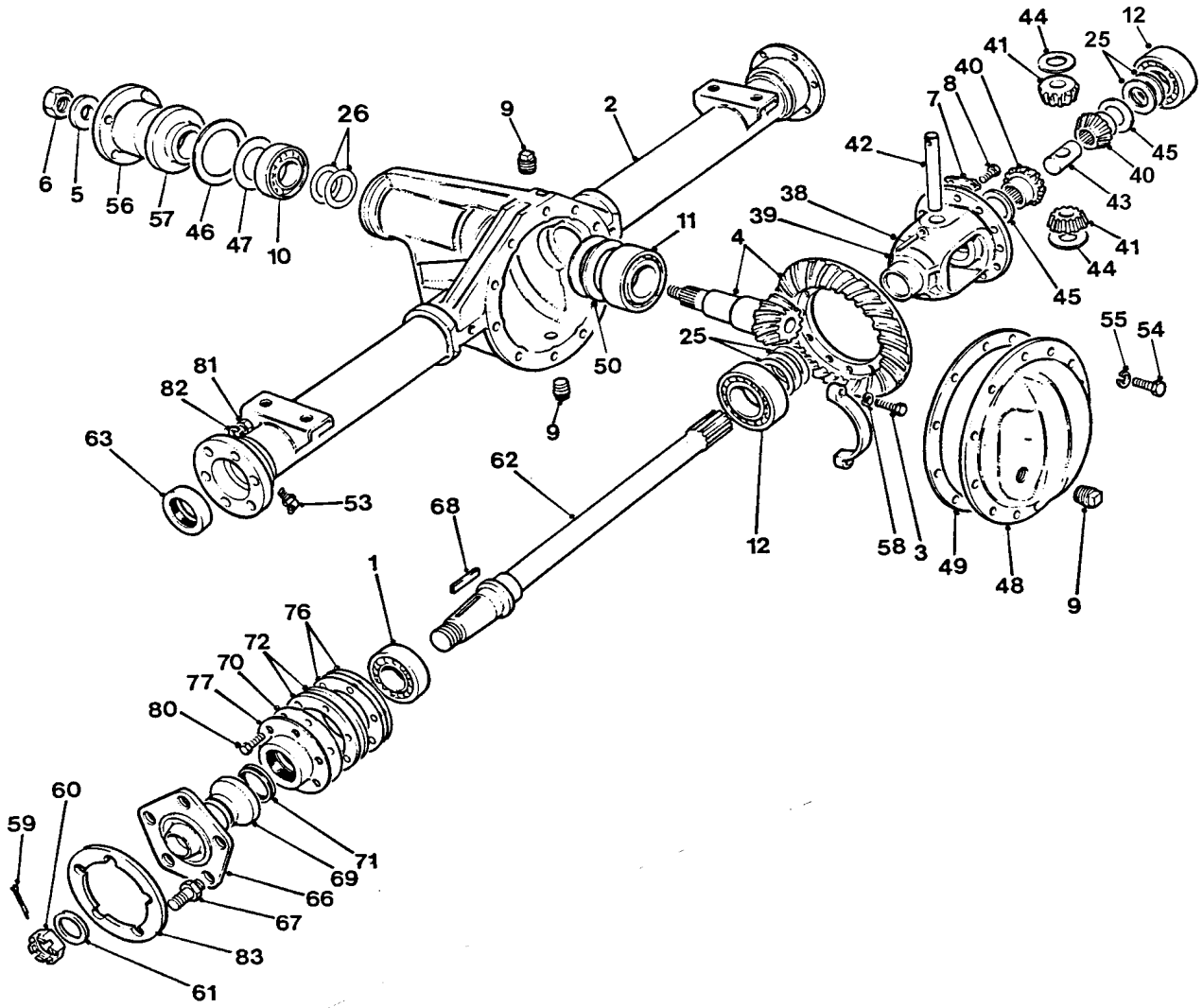

DRIVE AXLE, Salisbury non braked

B - 6

Item	Part no	Serial no	Description	Qty
-	30171A01		AXLE, assembly	1
1	30166A0101		BEARING	2
2	30171A0101		CARRIER & TUBE, assembly	1
3	30166A0103		BOLT, diff bearing cap	4
4	30166A0104		GEAR, assembly	1
5	30166A0105		WASHER	1
6	30166A0106		NUT, pinion locking	1
7	30166A0107		STRAP, 'L', drive gear	6
8	30166A0108		BOLT, drive gear	12
9	30166A0109		PLUG, level/filler	3
10	30166A0110		BEARING	1
11	30166A0111		BEARING	1
12	30166A0112		BEARING	2
25	30166A0113		SHIM, diff bearing, 0.028"	AR
25	30166A0114		SHIM, diff bearing, 0.030"	AR
25	30166A0115		SHIM, diff bearing, 0.031"	AR
25	30166A0116		SHIM, diff bearing, 0.032"	AR
25	30166A0117		SHIM, diff bearing, 0.033"	AR
25	30166A0118		SHIM, diff bearing, 0.034"	AR
25	30166A0119		SHIM, diff bearing, 0.035"	AR
25	30166A0120		SHIM, diff bearing, 0.036"	AR
25	30166A0121		SHIM, diff bearing, 0.037"	AR
25	30166A0122		SHIM, diff bearing, 0.038"	AR
25	30166A0123		SHIM, diff bearing, 0.039"	AR
25	30166A0124		SHIM, diff bearing, 0.040"	AR
25	30166A0125		SHIM, diff bearing, 0.045"	AR
26	30166A0126		SHIM, outer pinion bearing, 0.030"	AR
26	30166A0127		SHIM, outer pinion bearing, 0.031"	AR
26	30166A0128		SHIM, outer pinion bearing, 0.032"	AR
26	30166A0129		SHIM, outer pinion bearing, 0.033"	AR
26	30166A0130		SHIM, outer pinion bearing, 0.034"	AR
26	30166A0131		SHIM, outer pinion bearing, 0.035"	AR
26	30166A0132		SHIM, outer pinion bearing, 0.036"	AR
26	30166A0133		SHIM, outer pinion bearing, 0.037"	AR
26	30166A0134		SHIM, outer pinion bearing, 0.038"	AR
26	30166A0135		SHIM, outer pinion bearing, 0.039"	AR
26	30166A0136		SHIM, outer pinion bearing, 0.040"	AR
-	30166A0137		DIFFERENTIAL CASE, assembly	1
38	30166A0138		PIN, roll	1
39	30166A0139		CASE, differential	1
40	30166A0140		GEAR, side, diff	2
41	30166A0141		MATE, diff pinion	2
42	30166A0142		SHAFT, diff pinion mate	1
43	30166A0143		SPACER, axle shaft	1

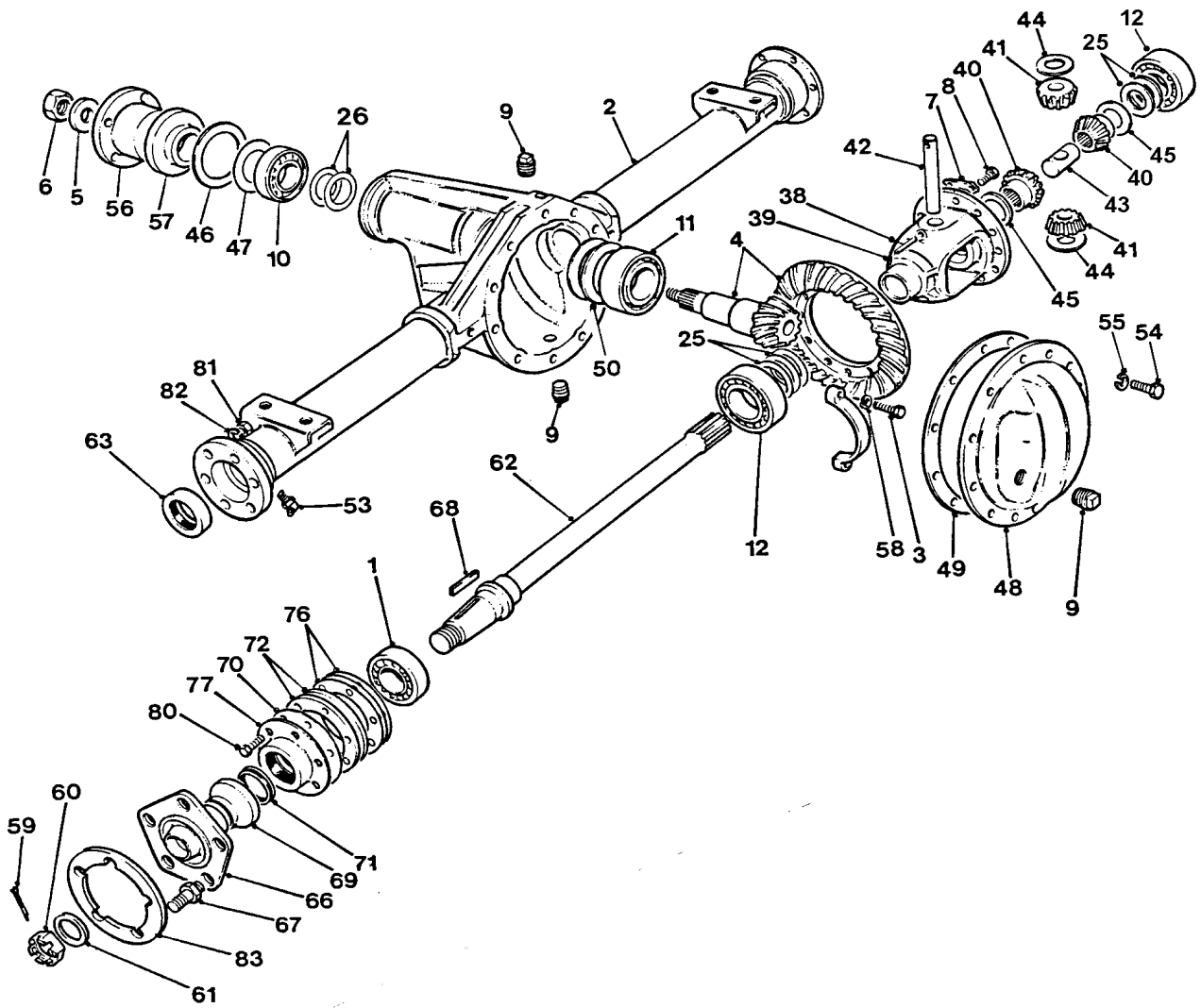

DRIVE AXLE, Salisbury non braked

B - 6

Item	Part no	Serial no	Description	Qty
44	30166A0144		WASHER, thrust	2
45	30166A0145		WASHER, thrust	2
46	30166A0146		GASKET, pinion oil seal	1
47	30166A0147		SLINGER, pinion oil	1
48	30166A0148		COVER, gear carrier	1
49	30166A0149		COVER, gasket	1
50	30166A0150		SHIM, inner pinion bearing, 0.003"	AR
50	30166A0151		SHIM, inner pinion bearing, 0.005"	AR
50	30166A0152		SHIM, inner pinion bearing, 0.010"	AR
53	30166A0176		NIPPLE, grease	2
54	30166A0153		BOLT, carrier cover	10
55	30166A0154		WASHER, locking	10
56	30166A0155		FLANGE, companion	1
57	30166A0156		SEAL, oil, pinion	1
58	30166A0157		WASHER, locking, diff bearing cap	4
59	30166A0158		PIN, cotter	2
60	30166A0159		NUT, shaft	2
61	30166A0160		WASHER, shaft	2
62	30166A0180		SHAFT, axle	2
63	30166A0161		SEAL, oil, axle shaft	2
-	30171A0102		WHEEL HUB, assembly	2
66	30171A0104		HUB, wheel	1
67	30171A0103		DOWEL, stud locking	5
67	30171A0105		STUD, wheel	10
68	30166A0169		KEY, axle shaft	2
69	30171A0106		HOUSING, 'V' ring	2
70	30166A0170		GASKET, hub oil seal	2
71	30171A0107		SEAL, 'V' ring	2
72	30171A0108		PLATE, retainer	4
76	30166A0172		SHIM, wheel bearing, 0.003"	AR
76	30166A0173		SHIM, wheel bearing, 0.005"	AR
76	30166A0174		SHIM, wheel bearing, 0.010"	AR
76	30166A0175		SHIM, wheel bearing, 0.030"	AR
77	30166A0177		SEAL, oil, hub, assembly	2
78	30166A0178		CONTAINER, oil seal	1
79	30166A0179		SEAL, oil	1
80	30166A0167		BOLT	12
81	30171A0109		NUT, locking	12
82	30171A0110		WASHER	12
83	ASE127		SPACER	2
-	6S05C	Axle fixings	BOLT	4
-	132S05	(not illustrated)	NUT	4
-	10S04		WASHER	4

DRIVE AXLE, Salisbury oil immersed**B - 7**

Item	Part no	Serial no	Description	Qty
-	30242A01		AXLE, assembly	1
1	30242A0101		STUD, nylon patch locking	16
2	30242A0102		WASHER, locking	16
3	30242A0103		NUT	16
4	30242A0104		CIRCLIP	12
5	30242A0105		WASHER, locking	18
6	30242A0106		STUD	16
7	30242A0107		BOLT	4
8	30242A0108		WASHER, locking	4
9	30242A0109		SCREW & WASHER	16
10	30242A0110		COVER, brake link access	2
11	30242A0111		BEARING	2
12	30166A0110		BEARING	1
13	30166A0111		BEARING	1
14	30166A0112		BEARING	2
15	30242A0112		GASKET, brake housing cover	2
16	30242A0113		PIN, brake	2
17	30242A0114		LEVER, brake operating	4
18	30242A0115		PIN	2
19	30242A0116		CLEVIS	2
20	30242A0117		PIN, clevis	2
21	30242A0118		SLAVE CYLINDER, assembly	2
22	30242A0119		ROD, push	1
23	30242A0120		PIN	2
24	30242A0121		SLEEVE, push rod	2
25	30242A0122		SPACER, pivot	4
26	30242A0123		SHAFT, axle	2
27	30242A0124		HOUSING, bearing	2
28	30242A0125		HUB & STUD, assembly	2
29	30166A0166		STUD, wheel	5
30	30242A0127		SEAL, oil, rubber	2
31	30242A0153		SEAL, oil, leather	2
32	30242A0128		SHIM, wheel bearing, 0.08mm	2
32	30242A0129		SHIM, wheel bearing, 0.125mm	2
32	30242A0130		SHIM, wheel bearing, 0.25mm	2
32	30242A0131		SHIM, wheel bearing, 0.8mm	2
32	30242A0149		SHIM SPACER, 2.5mm	2
36	30242A0132		SEAL, 'O' ring	2
37	30242A0133		CARRIER & TUBE, brake housing	1
38	30166A0103		BOLT, diff bearing cap	4

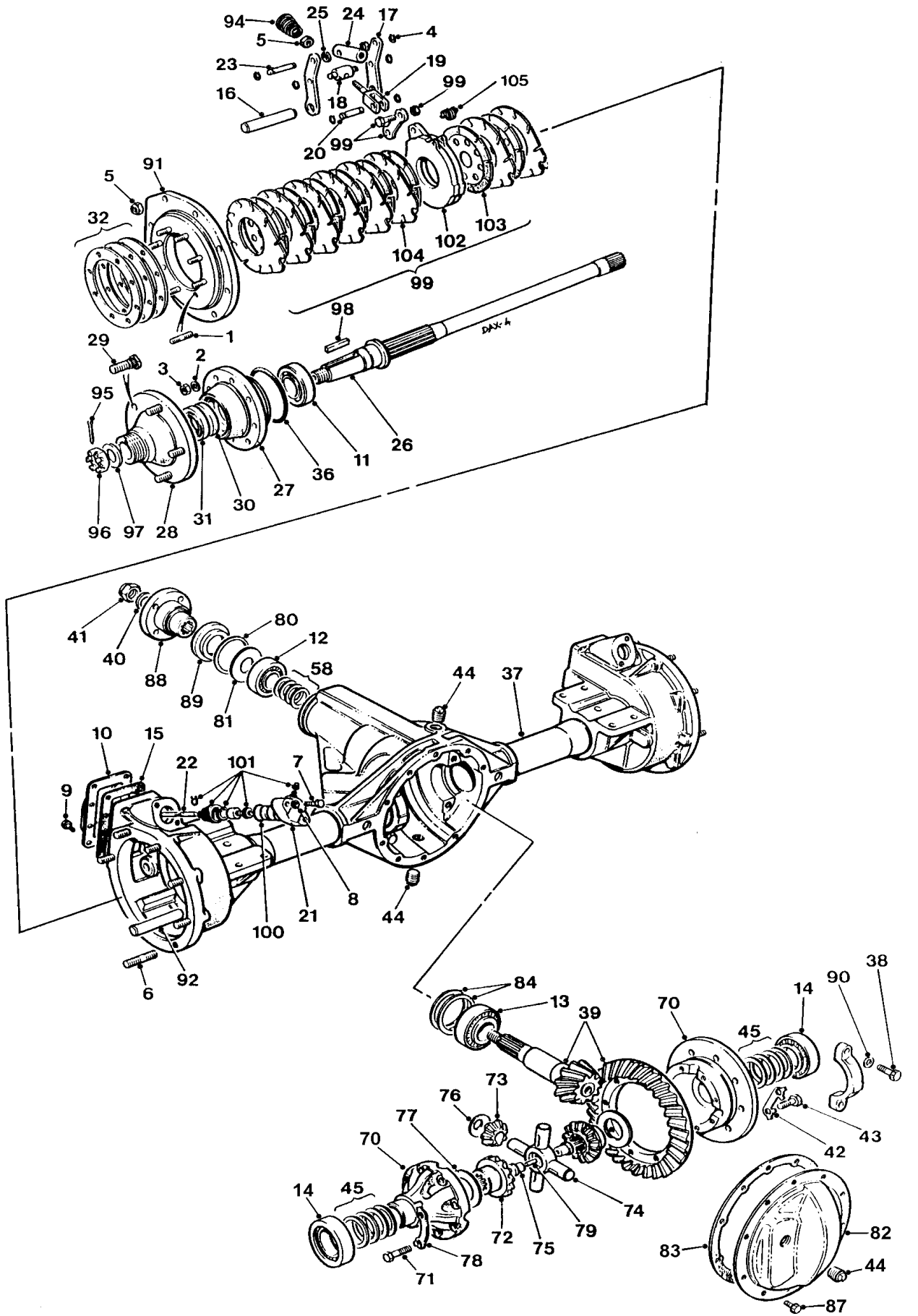

DRIVE AXLE, Salisbury oil immersed

B - 7

Item	Part no	Serial no	Description	Qty
39	30166A0104		GEAR, assembly	1
40	30166A0105		WASHER	1
41	30166A0106		NUT, pinion locking	1
42	30166A0107		STRAP, 'L', drive gear	6
43	30166A0108		BOLT, drive gear	12
44	30166A0109		PLUG, level/filler	3
45	30166A0113		SHIM, diff bearing, 0.028"	AR
45	30166A0114		SHIM, diff bearing, 0.030"	AR
45	30166A0115		SHIM, diff bearing, 0.031"	AR
45	30166A0116		SHIM, diff bearing, 0.032"	AR
45	30166A0117		SHIM, diff bearing, 0.033"	AR
45	30166A0118		SHIM, diff bearing, 0.034"	AR
45	30166A0119		SHIM, diff bearing, 0.035"	AR
45	30166A0120		SHIM, diff bearing, 0.036"	AR
45	30166A0121		SHIM, diff bearing, 0.037"	AR
45	30166A0122		SHIM, diff bearing, 0.038"	AR
45	30166A0123		SHIM, diff bearing, 0.039"	AR
45	30166A0124		SHIM, diff bearing, 0.040"	AR
45	30166A0125		SHIM, diff bearing, 0.045"	AR
58	30166A0126		SHIM, outer pinion bearing, 0.030"	AR
58	30166A0127		SHIM, outer pinion bearing, 0.031"	AR
58	30166A0128		SHIM, outer pinion bearing, 0.032"	AR
58	30166A0129		SHIM, outer pinion bearing, 0.033"	AR
58	30166A0130		SHIM, outer pinion bearing, 0.034"	AR
58	30166A0131		SHIM, outer pinion bearing, 0.035"	AR
58	30166A0132		SHIM, outer pinion bearing, 0.036"	AR
58	30166A0133		SHIM, outer pinion bearing, 0.037"	AR
58	30166A0134		SHIM, outer pinion bearing, 0.038"	AR
58	30166A0135		SHIM, outer pinion bearing, 0.039"	AR
58	30166A0136		SHIM, outer pinion bearing, 0.040"	AR
-	30242A0134		DIFFERENTIAL CASE, assembly	1
70	30242A0135		CASE, diff	1
71	30242A0136		BOLT, diff case	8
72	30242A0137		GEAR, side	2
73	30242A0138		PINION, mete	4
74	30242A0139		CROSS SHAFT, pinion mate	1
75	30242A0140		SPACER, split, axle shaft	2
76	30242A0141		WASHER, thrust, diff pinion mate	4
77	30242A0142		WASHER, thrust, diff side gear	2
78	30242A0143		STRAP, locking, diff case	4
79	30242A0144		PIN, roll	1

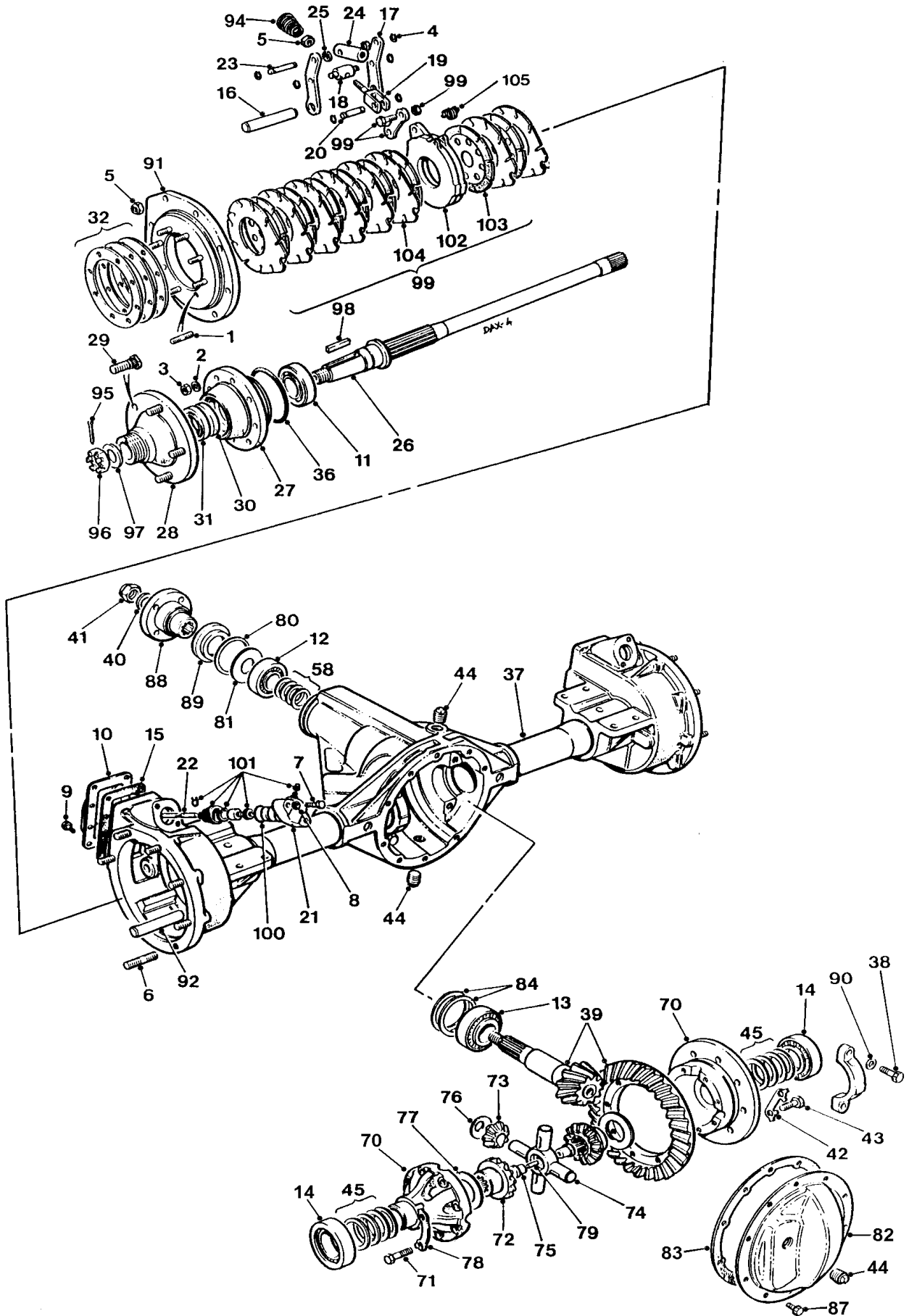

Item	Part no	Serial no	Description	Qty
80	30166A0146		GASKET, pinion oil seal	1
81	30166A0147		SLINGER, oil, pinion	1
82	30242A0145		COVER, gear carrier	1
83	30166A0149		GASKET, carrier cover	1
84	30166A0150		SHIM, pinion bearing inner, 0.003"	AR
84	30166A0151		SHIM, pinion bearing inner, 0.005"	AR
84	30166A0152		SHIM, pinion bearing inner, 0.010"	AR
87	30242A0146		BOLT & WASHER	10
88	30166A0155		FLANGE, companion	1
89	30166A0156		SEAL, oil, pinion	1
90	30166A0157		WASHER, locking, diff bearing cap	4
91	30242A0147		COVER, brake & spindle housing	2
92	30242A0148		PIN, anchor, brake	2
94	30242A0150		SPRING, return, conical	2
95	30166A0158		PIN, cotter	2
96	30166A0159		NUT, shaft	2
97	30166A0160		WASHER, shaft	2
98	30166A0169		KEY	2
99	30242A0152		BRAKE & DISC, assembly, 8 plate (includes items 102, 103, 104)	2
100	30242A0154		SEAL, 'O' ring	2
101	30242A0155		KIT, seal, slave cylinder	2
102	30242A0156		ACTUATOR	2
103	30242A0157		PLATE, brake, middle	16
104	30242A0158		PLATE, brake, intermediate	16
105	30242A0159		SPRING	2

Axle fixings (not illustrated)

-	6S05E	BOLT	8
-	132S05	NUT	8
-	10S04	WASHER	8

Newage Axles

Dumper with front & rear axle braking

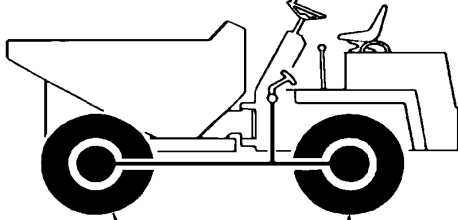

Dumper with front axle braking only

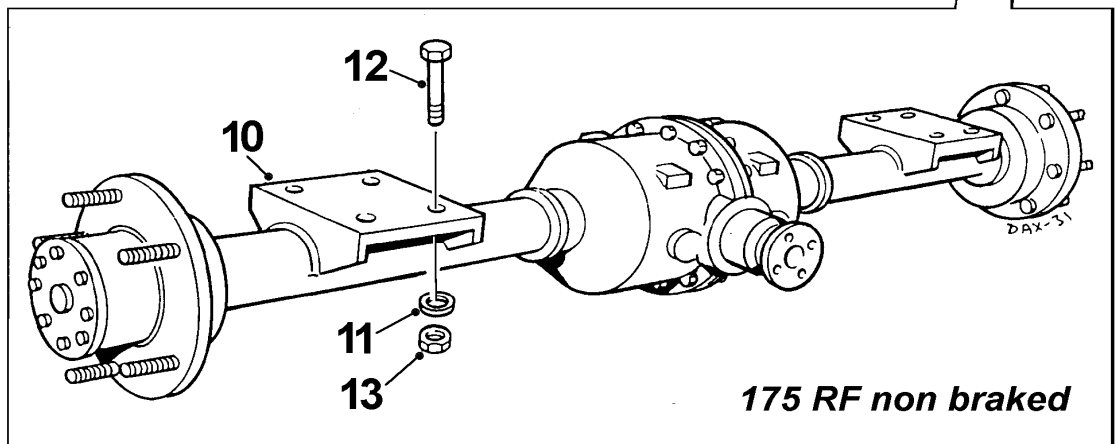
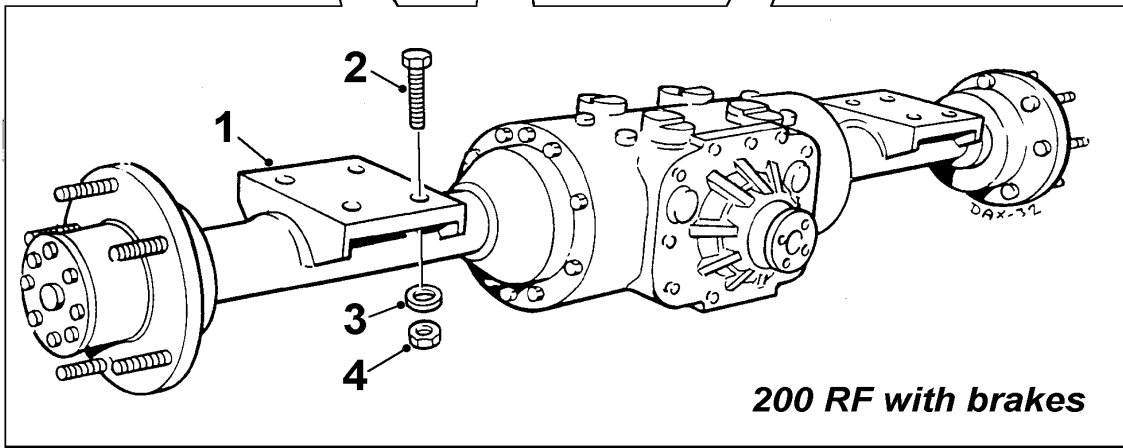
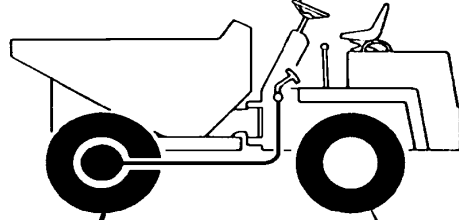

Item	Part no	Serial no	Description	Qty
1	—————	/ 1092	AXLE, type 200RF, with brakes (see page B - 8)	
2	6S05F	/ 1092	BOLT	8
3	10S04	/ 1092	WASHER, flat	8
4	107S16	/ 1092	NUT, self-locking	8
10	—————	/ 1092	AXLE, type 175RF, without brakes (see page B - 9)	
11	10S04	/ 1092	WASHER, flat	8
12	6S05C	/ 1092	BOLT	8
13	107S16	/ 1092	NUT, self-locking	8

Newage Axles

Dumper with front & rear axle braking

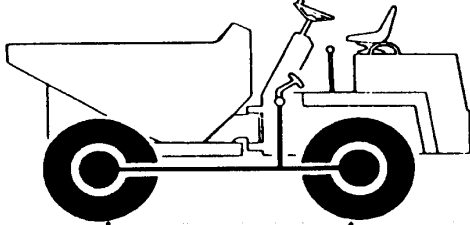

Dumper with front axle braking only

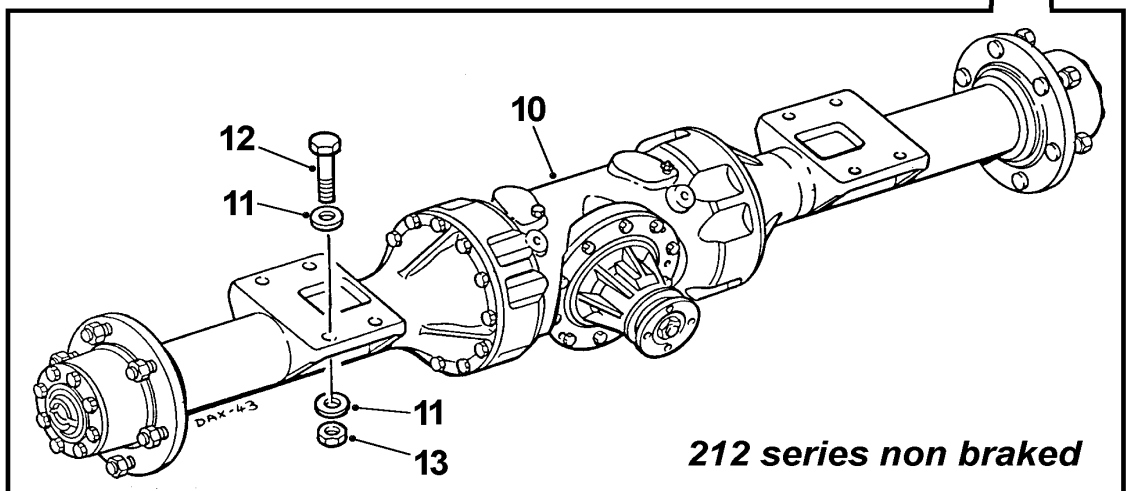
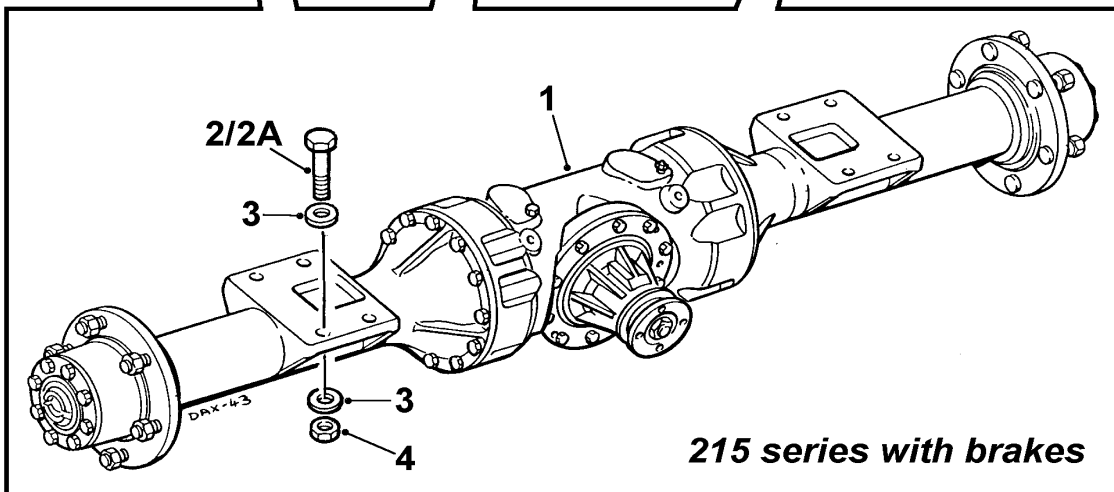
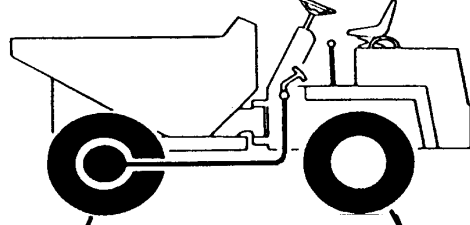

Item	Part no	Serial no	Description	Qty
1	30156A13	1093 /	AXLE, 215B14W131, with brakes (see page B - 11)	
2	8S06K	1093 /	BOLT, (<i>Front axle fixing</i>)	8
2A	8S06G	1093 /	BOLT, (<i>Rear axle fixing</i>)	8
3	267S09	1093 /	WASHER, flat	8
4	59S11	1093 /	NUT, self-locking, 'Nyloc'	8
10	30156A12	1093 /	AXLE, 21214W131, without brakes (see page B - 10)	
11	267S09	1093 /	WASHER, flat	8
12	8S06G	1093 /	BOLT	8
13	59S11	1093 /	NUT, self-locking, 'Nyloc'	8

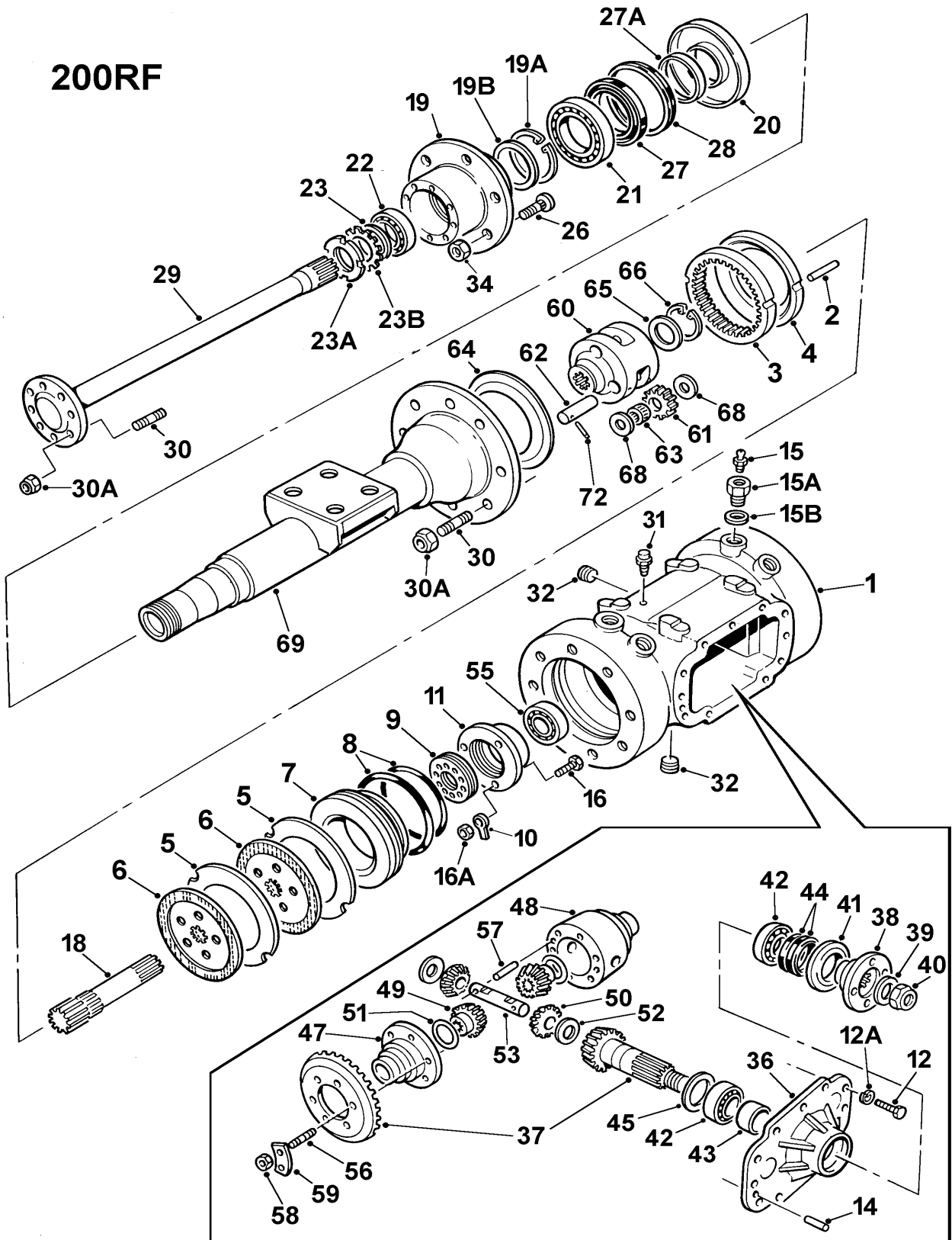

DRIVE AXLE, Newage, braked

B - 8

Item	Part no	Axle serial no	Description	Qty
-	30156A05		* AXLE, assembly (stamped 200RF14S321 on axle casing)	1
-	30156A05		+ AXLE, assembly (stamped 200RFD14S321 on axle casing)	1
-	30156A09		+ AXLE, assembly (stamped 200RF14S3210 on axle casing)	1

Note: Items marked * should only be used on axles marked 200RF14S321 on axle casing.

Items marked + should only be used on axles marked 200RFD14S321 or 200RF14S3210 on axle casing.

All other items are common.

1	30156A0101		CASING, axle	1
2	30156A0102		PIN, dowel	4
3	30156A0103	/ 1530214	ANNULUS	2
3	30156A0202	1530215 /	ANNULUS	2
4	30156A0104	/ 1530214	PLATE, brake spacer	2
4	30156A0206	1530215 /	PLATE, brake spacer	2
5	30156A0105		PLATE, brake, fixed	4
6	30156A0106		DISC, brake	4
7	30156A0107		PISTON, brake	2
8	30156A0108		SEAL, piston (one set)	1
9	30156A0109		NUT, bearing adjusting	2
10	30156A0110		PLATE, bearing adjusting nut	2
11	30156A0111		HOUSING, bearing	2
12	11S03C		SCREW, set	12
12A	17S04		WASHER, spring	12
14	30156A0112		PIN, dowel	2
15	182S20		VALVE, brake bleed	2
15A	30347A0218		ADAPTOR, brake pipe	4
15B	30156A0155		SEAL, bonded	4
16	11S04D		SCREW, set	6
16A	59S03		NUT, nyloc	6
18	30156A0114	/ March 86	* SUN GEAR, 22 teeth spline	2
18	30156A0907	March 86 /	+ SUN GEAR, 25 teeth spline	2

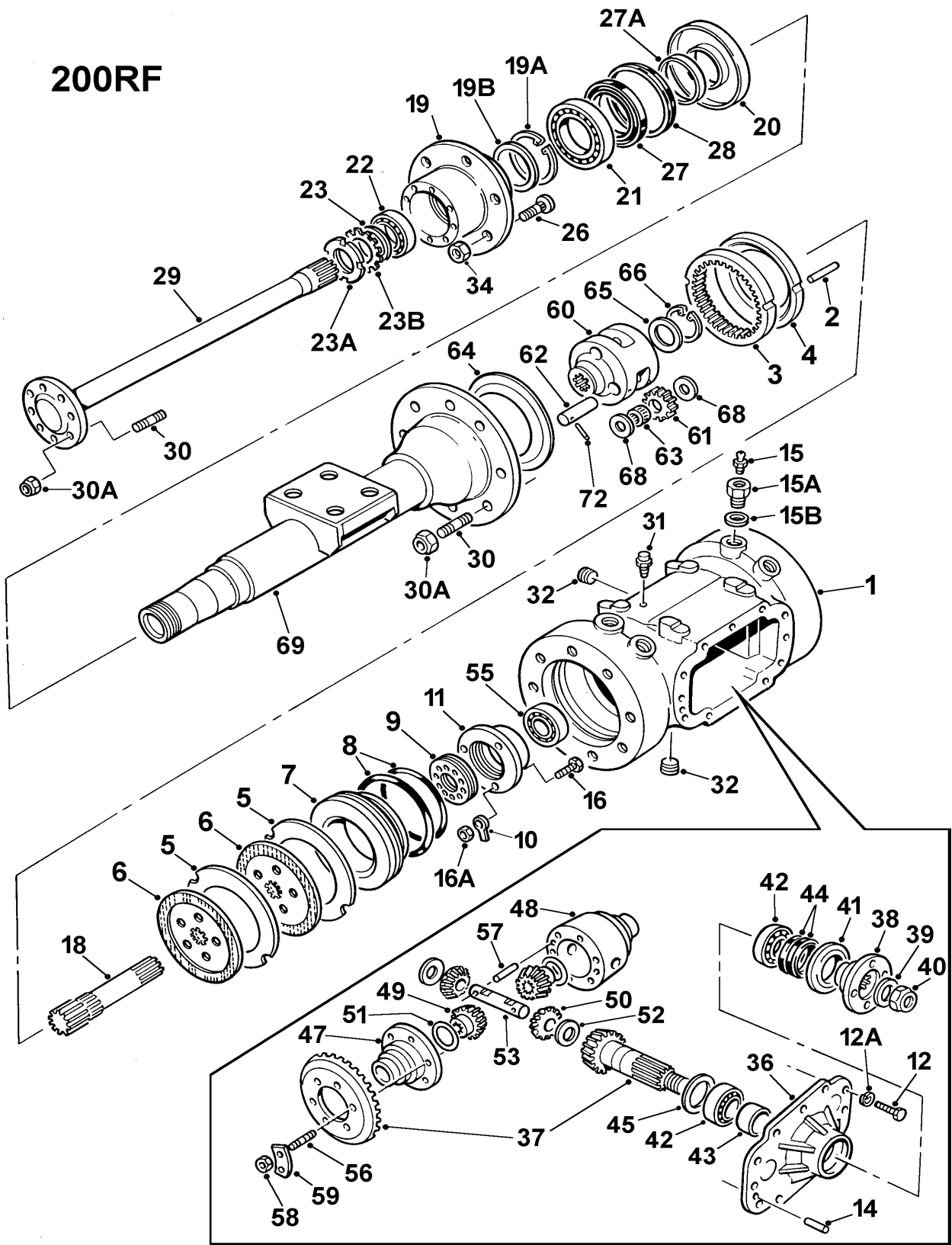

DRIVE AXLE, Newage, braked

B - 8

Item	Part no	Axle serial no	Description	Qty
19	30156A0115	/ 1507133	* HUB	2
19	30156A0903	1507134 /	+ HUB	2
19A	V600166	1507134 /	+ CIRCLIP	1
19B	V600165	1507134 /	+ SPACER	1
20	30156A0116		HOUSING, oil seal	2
21	30082A0221		BEARING, hub inner	2
22	30156A0118	/ 1507133	BEARING hub outer	2
22	30156A0180	1507134 /	BEARING, hub outer	2
23	30156A0119	/ 1507133	SPACER	2
23	30156A0181	1507134 /	SPACER	2
23A	30156A0120	/ 1507133	NUT, locking	2
23A	30156A0182	1507134 /	NUT, locking	2
23B	30156A0121	/ 1507133	WASHER, tab	2
23B	30156A0183	1507134 /	WASHER, tab	2
26	30156A0122		STUD, wheel	10
27	30156A0123	/ 1507133	SEAL, oil	2
27	30156A0184	1507134 /	SEAL, oil	1
27A	30156A0193	1507134 /	SLEEVE	1
28	30156A0124		SEAL, 'V' ring	2
29	30156A0125	/ April 87	* SHAFT, axle, 21 teeth spline	2
29	30156A0902	May 87 /	+ SHAFT, axle, 22 teeth spline	2
30	30156A0126		STUD	44
30A	59S03		NUT, nyloc	44
31	10305A01		VALVE, breather	1
32	30156A0127		PLUG, hex socket	2
34	-		NUT, wheel (see page B - 1)	10
36	30156A0129		HOUSING, input pinion	1
37	30156A0163		BEVEL WHEEL & PINION	1
38	30156A0131		FLANGE, drive	1
39	30082A0231		WASHER, drive flange	1
40	30082A0232		NUT, drive flange	1
41	30156A0134		COVER, oil seal	1
42	30156A0135		BEARING, pinion	2
43	30156A0136		SPACER, pinion bearing	1
44	30156A0137		SEAL, oil, pinion	1
45	30156A0138		SHIM, pinion adjusting, 0.30mm	AR
45	30156A0139		SHIM, pinion adjusting, 0.25mm	AR
45	30156A0140		SHIM, pinion adjusting, 0.40mm	AR

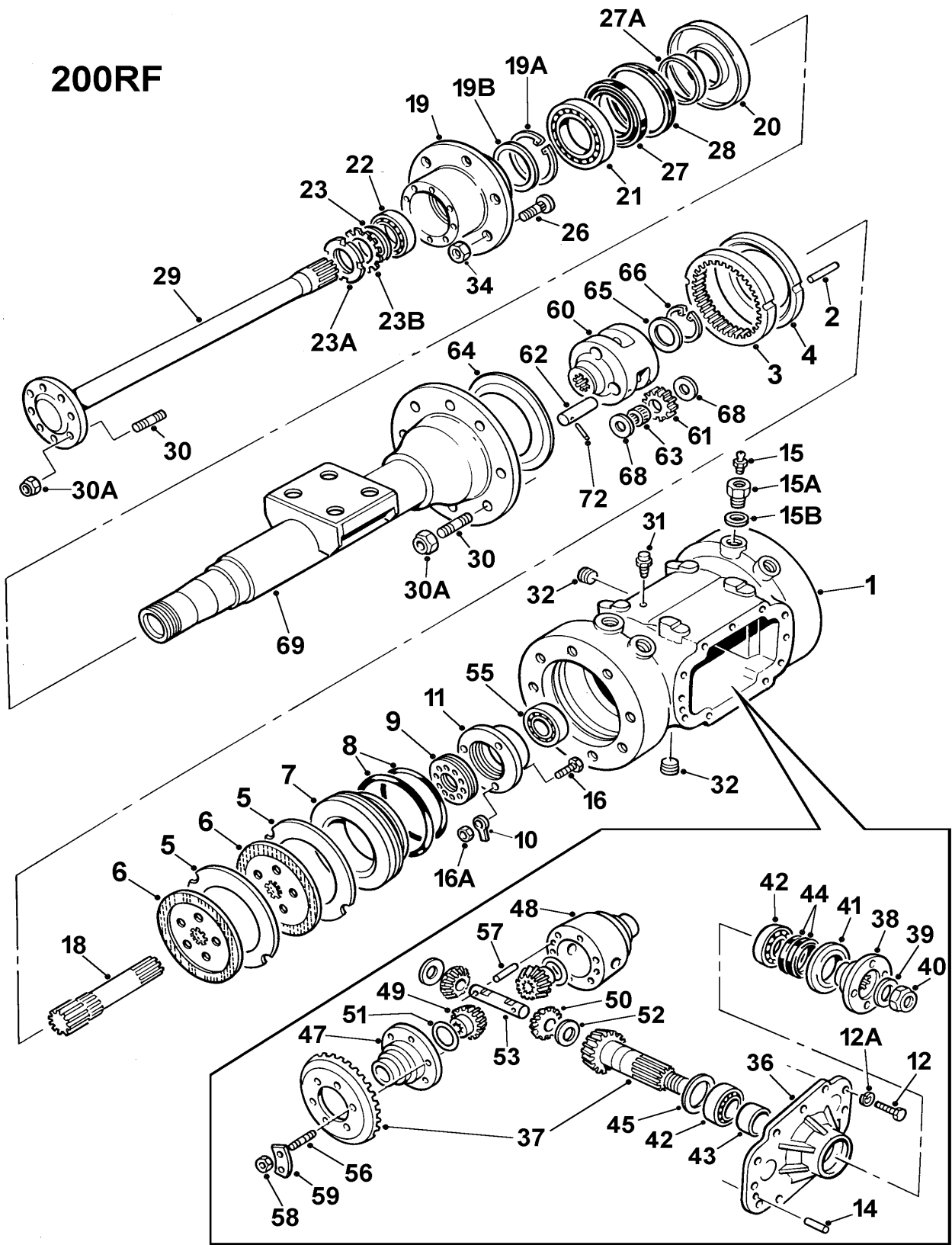

DRIVE AXLE, Newage, braked

B - 8

Item	Part no	Axle serial no	Description	Qty
47	30156A0142	/ 1504166	* COVER, differential	1
47	30156A0906	1504167/	+ COVER, differential	1
48	30156A0150	/ 1504166	* CASING, differential	1
48	30082A0302	1504167/	+ CASING, differential	1
49	30156A0143	/ 1504166	* WHEEL, differential	2
49	30082A0283	1504167/	+ WHEEL, differential	2
50	30082A0284		PINION, differential	2
51	30156A0144	/ 1504166	* THRUST WASHER, diff. wheel	2
51	30082A0241	1504167/	+ THRUST WASHER, diff. wheel	2
52	30082A0242		THRUST WASHER, diff. pinion	2
53	30156A0146	/ 1504166	SPIDER, differential	1
53	30082A0303	1504167/	SPIDER, differential	1
55	119325000		BEARING, differential	2
56	30082A0304		STUD	10
57	30082A0306		DOWEL, spring	1
58	7S04		NUT	10
59	30082A0305		TAB, locking strip	4
60	30156A0152	/ April 87	* PLANET CARRIER, 21 teeth spline	1
60	30156A0901	May 87 / 1530214	+ PLANET CARRIER, 22 teeth spline	1
60	30156A0802	1530215 /	+ PLANET CARRIER	1
61	30156A0153	/ 1530214	GEAR, planet	3
61	30156A0803	1530215 /	GEAR, planet	3
62	30156A0154	/ 1530214	PIN, planet gear	3
62	30156A0804	1530215 /	PIN, planet gear	3
63	30156A0178	/ 1530214	BEARING, needle roller (<i>imperial</i>)	3
63	30156A0289	1530215 /	BEARING, needle roller (<i>metric</i>)	3
64	30156A0156		SHIELD	2
65	30156A0157	/ 1530214	SPACER, axle shaft	1
65	30156A0805	1530215 /	SPACER, axle shaft	1
66	30082A0265		CIRCLIP	1
68	30082A0249		THRUST WASHER, planet	6
69	30156A0160	/ 1507133	* ARM, axle	2
69	30156A0904	1507134 /	+ ARM, axle	2
72	30156A0162		DOWEL, spring	3

175RF

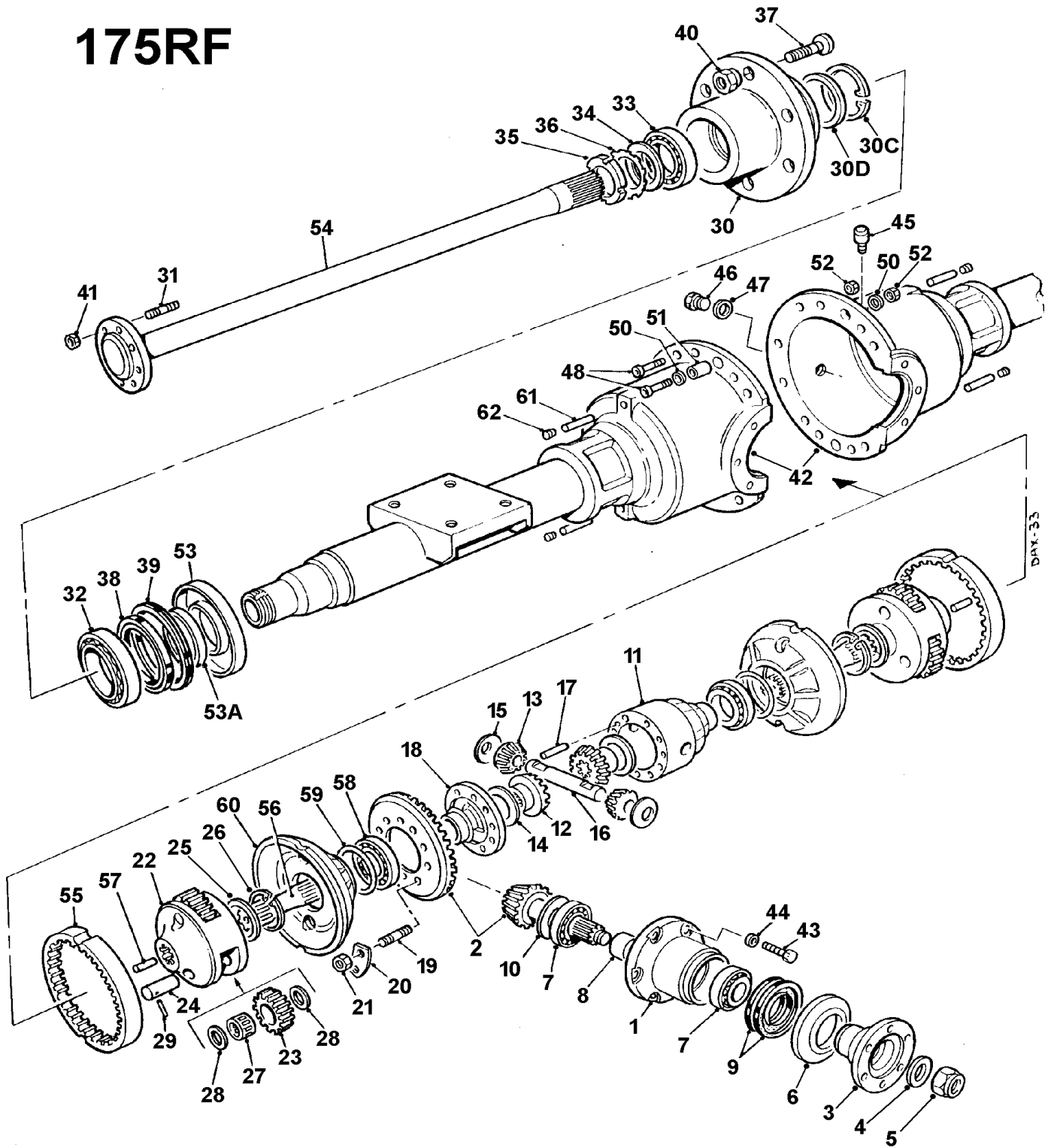

DRIVE AXLE, Newage, non braked

B - 9

Item	Part no	Axle serial no	Description	Qty
-	30312A02		* AXLE, assembly (stamped 175RF14S321 on axle casing)	1
-	30312A02		+ AXLE, assembly (stamped 175RFD14S321 on axle casing)	1
-	30312A04		+ AXLE, assembly (stamped 175RF14S3210 on axle casing)	1

Note: Items marked * should only be used on axles marked 175RF14S321 on axle casing.

Items marked + should only be used on axles marked 175RFD14S321 or 175RF14S3210 on axle casing.

All other items are common.

1	30156A0176		HOUSING, pinion	1
2	30156A0163		BEVEL WHEEL & PINION	1
3	30156A0131		FLANGE, input drive	1
4	30082A0231		WASHER	1
5	30082A0232		NUT	1
6	30156A0134		COVER, oil seal	1
7	30156A0135		BEARING	2
8	30156A0136		SPACER	1
9	30156A0137		SEAL, oil	2
10	30156A0138		SHIM, 0.3mm	AR
10	30156A0139		SHIM, 0.25mm	AR
10	30156A0140		SHIM, 0.4mm	AR
11	30156A0150	/ 1409968	* CASING, differential	1
11	30082A0302	1409969 /	+ CASING, differential	1
12	30156A0143	/ 1409968	* WHEEL, differential	2
12	30082A0283	1409969 /	+ WHEEL, differential	2
13	30082A0284		PINION, differential	2
14	30156A0144	/ 1409968	* WASHER, thrust, diff. wheel	2
14	30082A0241	1409969 /	+ WASHER, thrust, diff. wheel	2
15	30082A0242		WASHER, thrust, diff. pinion	2
16	30156A0146	/ 1409968	SPIDER	1
16	30082A0303	1409969 /	SPIDER	1

175RF

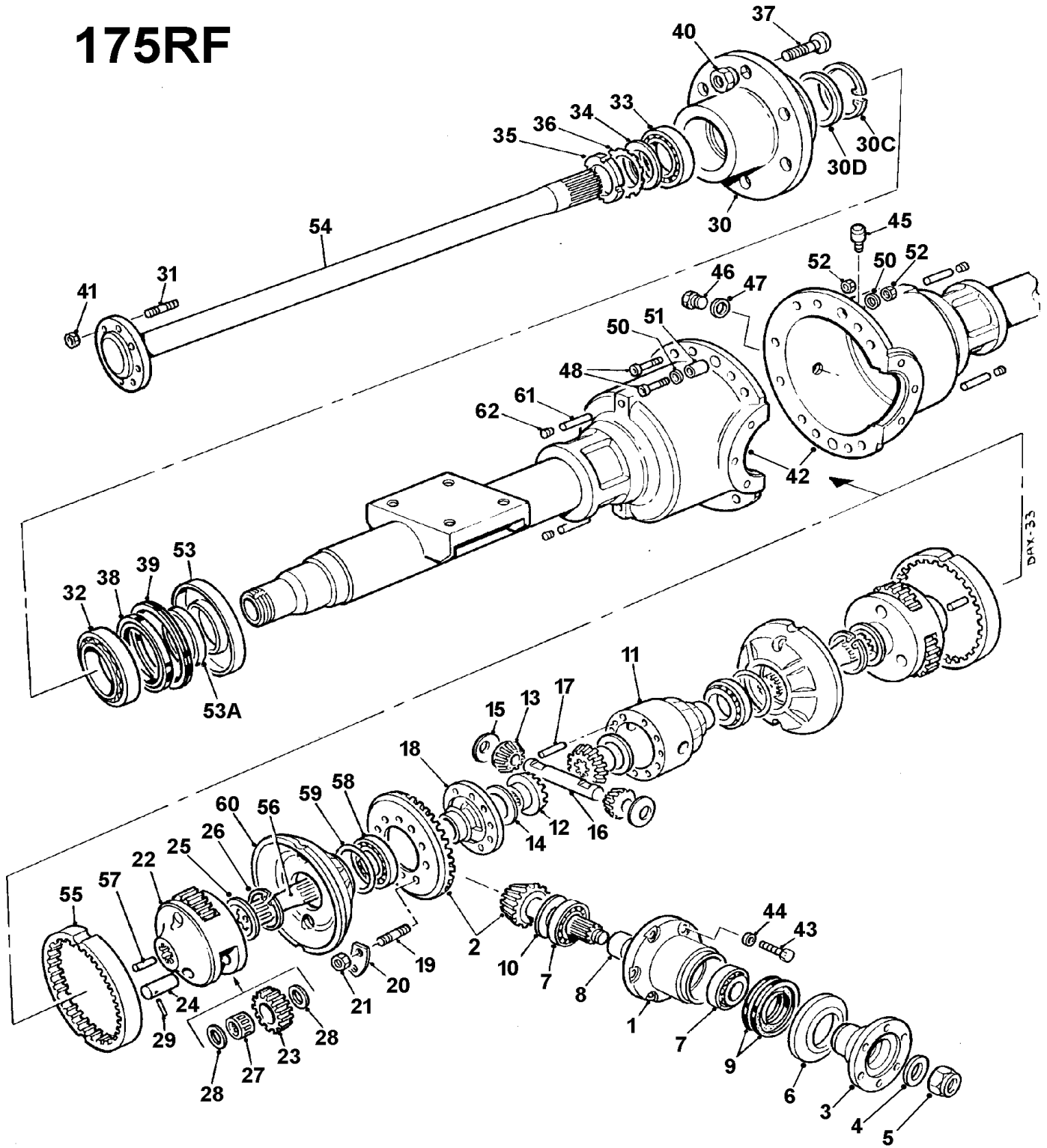

DRIVE AXLE, Newage, non braked

B - 9

Item	Part no	Axle serial no	Description	Qty
17	30082A0306		PIN, spirol	2
18	30156A0142	/ 1409968	* COVER, differential	1
18	30156A0906	1409969 /	+ COVER, differential	1
19	30082A0304		STUD	8
20	30082A0305		TAB, locking strip	4
21	7S04		NUT	8
22	30312A0202	/ April 87	* PLANET CARRIER, 21 teeth spline	2
22	30312A0401	May 87 / 1423312	+ PLANET CARRIER, 22 teeth spline	2
22	30312A0207	1423313 /	+ PLANET CARRIER	2
23	30156A0153	/ 1423312	GEAR, planet	4
23	30156A0803	1423313 /	GEAR, planet	4
24	30156A0174	/ 1423312	PIN, planet gears	4
24	30156A0804	1423313 /	PIN, planet gears	4
25	30156A0157	/ 1423312	SPACER, axle shaft	2
25	30156A0805	1423313 /	SPACER, axle shaft	2
26	30082A0265		CIRCLIP	2
27	30082A0252	/ 1423312	BEARING, needle roller, (imperial)	4
27	30082A0289	1423313 /	BEARING, needle roller, (metric)	4
28	30082A0249		WASHER, thrust	8
29	30156A0162		DOWEL	4
30	30156A0115	/ 1412518	* HUB	2
30	30156A0903	1412519 /	+ HUB	2
30C	30156A0185	1412519 /	+ CIRCLIP	2
30D	30156A0186	1412519 /	+ SPACER	2
31	30156A0126		STUD	16
32	30082A0221		BEARING	2
33	30156A0118	/ 1412518	BEARING	2
33	30156A0180	1412519 /	BEARING	2
34	30156A0119	/ 1412518	SPACER	2
34	30156A0181	1412519 /	SPACER	2
35	30156A0120	/ 1412518	NUT	2
35	30156A0182	1412519 /	NUT, locking	2
36	30156A0121	/ 1412518	WASHER, locking	2
36	30156A0183	1412519 /	WASHER, locking	2
37	30156A0122		STUD, wheel	10
38	30156A0123	/ 1412518	SEAL, oil	2
38	30156A0184	1412519 /	SEAL, oil	2

175RF

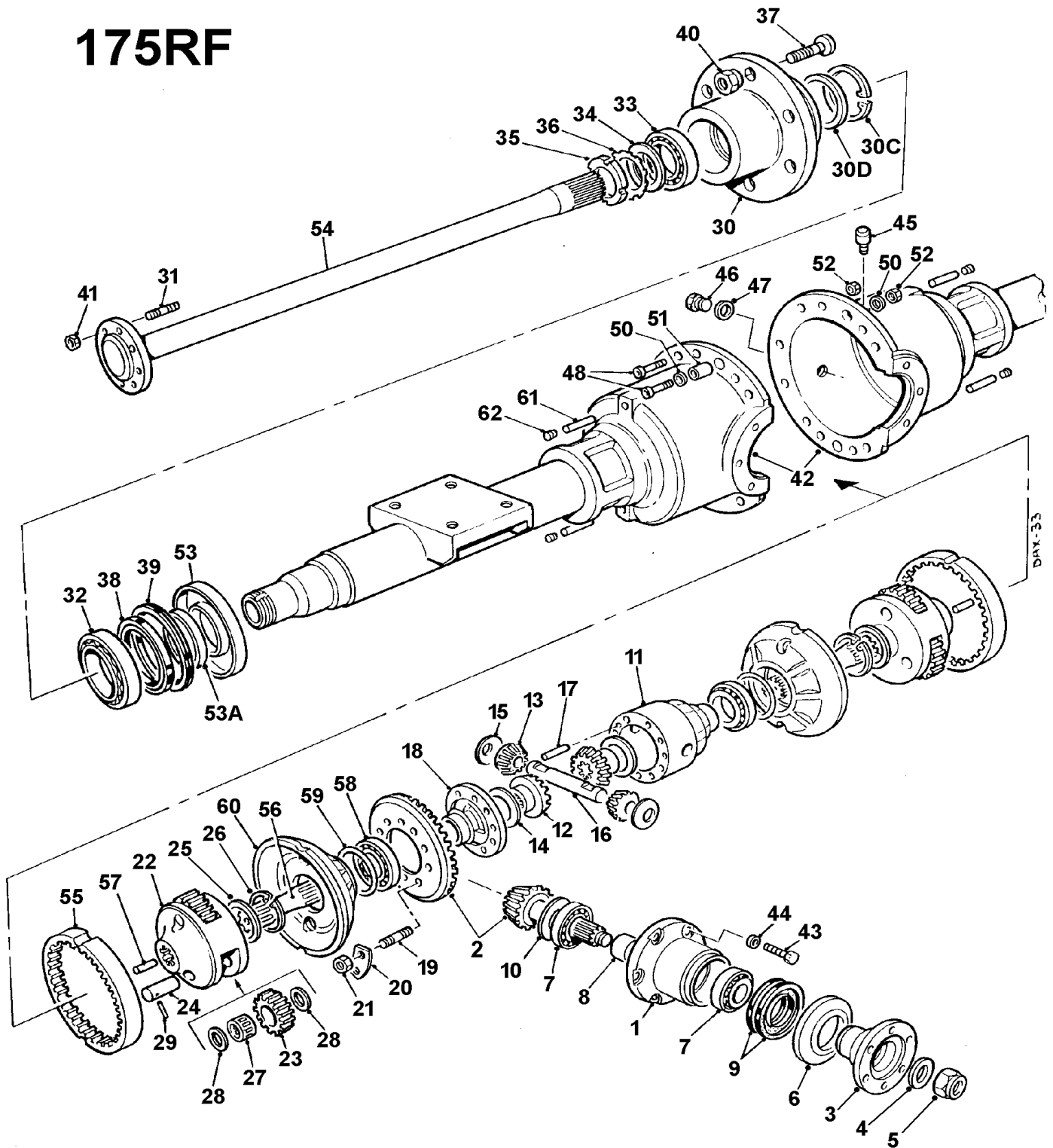

DRIVE AXLE, Newage, non braked

B - 9

Item	Part no	Axle serial no	Description	Qty
39	30156A0124		'V' RING	2
40	-----		NUT, wheel (see page B - 1)	10
41	30045A0219		NUT	16
42	30312A0204		CASE, axle	1
43	30312A0205		SCREW	6
44	30312A0206		WASHER	6
45	10305A01		BREATHER	1
46	30097A0163		PLUG	1
47	42S05		WASHER, fibre	1
47	100S04		SEAL, bonded	1
48	68S05G		BOLT	12
50	267S06		WASHER	4
51	30312A0210		DOWEL	2
52	59S03		NUT	12
53	30156A0116		HOUSING, oil seal	2
53A	30156A0193	1412519 /	SLEEVE	2
54	30312A0211	/ April 87	* SHAFT, axle, 21 teeth spline	2
54	30312A0402	May 87 /	+ SHAFT, axle, 22 teeth spline	2
55	30156A0103	/ 1423312	ANNULUS	2
55	30156A0202	1423313 /	ANNULUS	2
56	30312A0212	/ March 86	* GEAR, sun, 22 teeth spline	2
56	30312A0403	March 86/	+ GEAR, sun, 25 teeth spline	2
57	30312A0213		DOWEL	2
58	119325000		BEARING, cup & cone	2
59	30101A0715		SHIM, .002"	AR
59	30101A0716		SHIM, .010"	AR
60	30312A0214	/ 1423312	HOUSING, bearing	2
60	30312A0208	1423313 /	HOUSING, bearing	2
61	30156A0191		DOWEL	4
62	30156A0192		PLUG	4

212 series

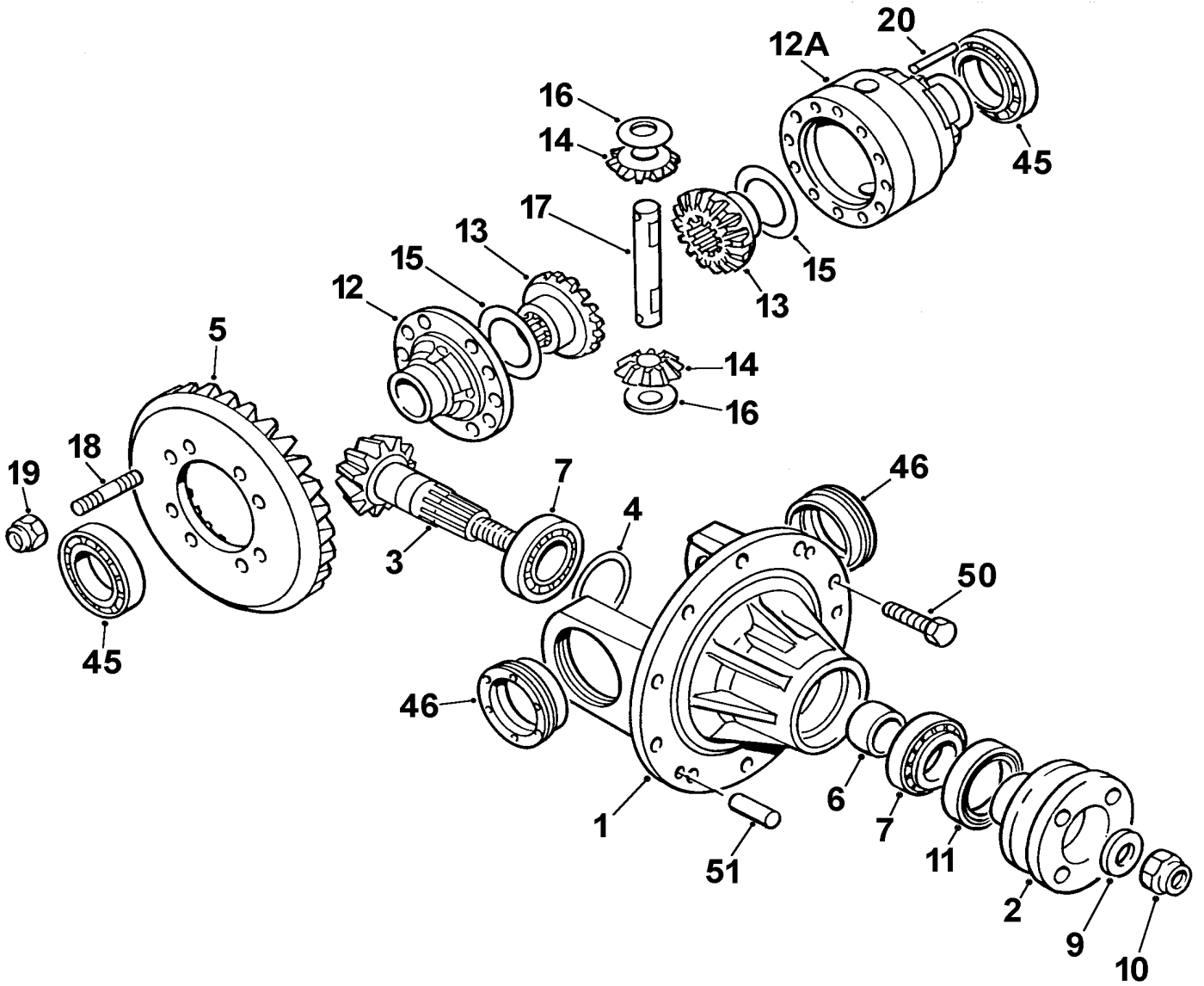

INPUT PINION & DIFFERENTIAL
Newage 212 series drive axle, (non braked)

B - 10

Item	Part no	Axle serial no	Description	Qty
1	30082A0401		PINION, input cartridge	1
2	30082A0402		FLANGE, input drive, c/w seal shield	1
3	30082A0403		PINION, supplied with item 5	1
4	30082A0282		SHIM, 0.25mm	2
....	30082A0280		SHIM, 0.3mm	2
....	30082A0281		SHIM, 0.4mm	2
5	30082A0403		CROWN WHEEL & PINION SET	1
6	30082A0235		SPACER	1
7	30082A0234		BEARING, cup & cone assembly	2
....	30082A0274		BEARING, cup	1
....	30082A0273		BEARING, cone	1
9	30082A0231		WASHER, plain	1
10	30082A0232		NUT	1
11	30082A0236		SEAL, oil	2
12	30082A0404		COVER, differential	1
12A	30082A0405		CASING, differential	1
13	30082A0283		WHEEL, differential	2
14	30082A0284		PINION, differential	2
15	30082A0241		WASHER, thrust	2
16	30082A0242		WASHER, thrust	2
17	30082A0303		SPIDER, differential, (half)	1
18	30082A0406		STUD	8
19	59S03		NUT, 'Nyloc'	8
20	30082A0306		PIN, Spirol	2
45	119325000		BEARING, cup & cone assy.	2
46	30082A0416		NUT, bearing adjustment	2
50	8S04B		BOLT	34
51	30156A0112		DOWEL, 10dia x 20mm	2

212 series

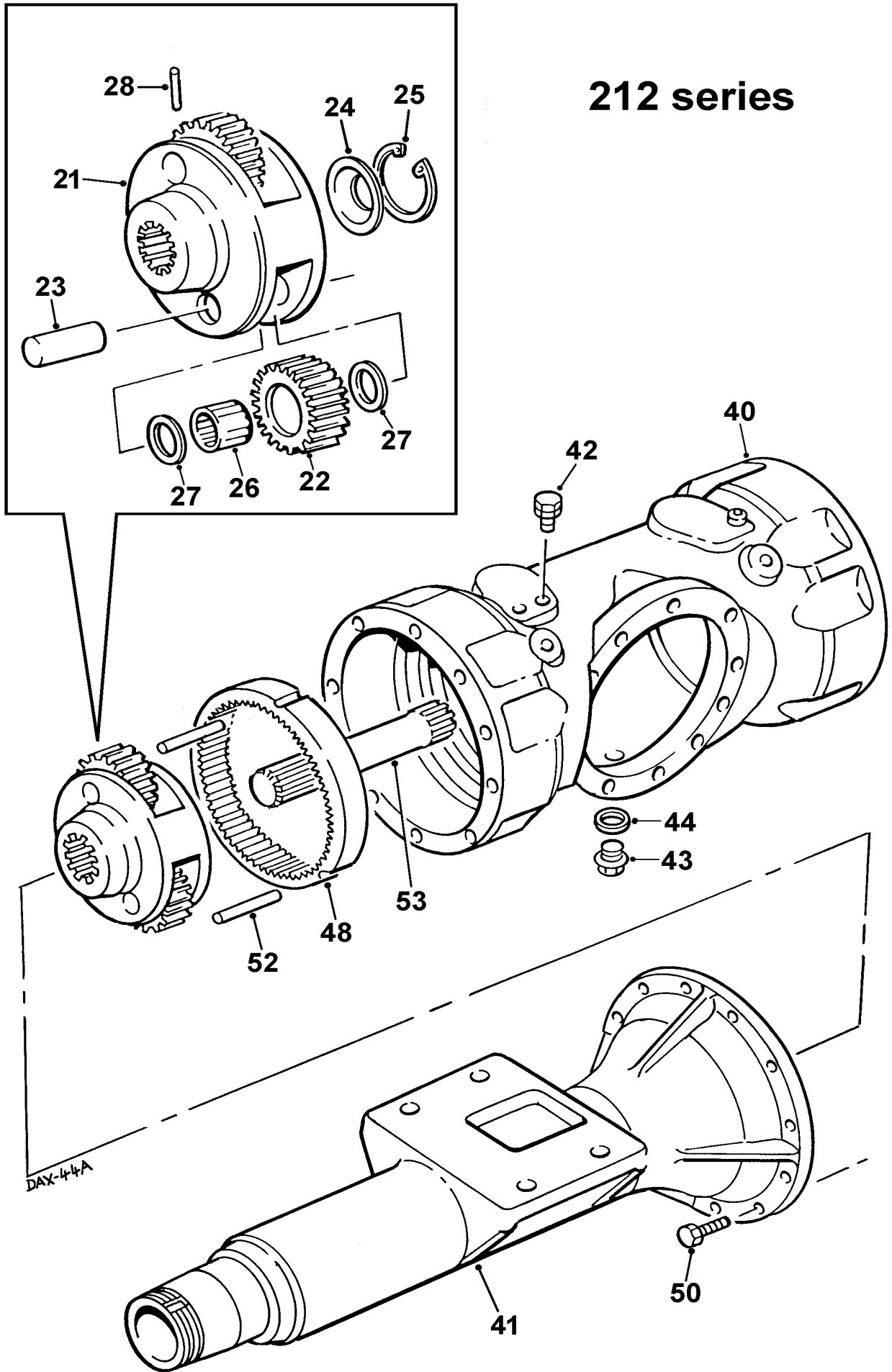

PLANET CARRIER & AXLE CASING
Newage 212 series drive axle, (non braked)

B - 10A

Item	Part no	Axle serial no	Description	Qty
21	30312A0207		CARRIER, planet	1
22	30156A0803		GEAR, planet	2
23	30156A0804		PIN, planet	2
24	30156A0805		SPACER	1
25	30082A0265		CIRCLIP	1
26	30082A0289		BEARING, needle	2
27	30082A0249		WASHER, thrust	4
28	30156A0162		DOWEL, spring	2
40	30082A0420		CASING, main (no brakes)	1
41	30082A0414		ARM, axle (1475mm)	2
42	30082A0415		BREATHER	1
43	30097A0163		PLUG, drain	2
44	100S04		SEAL, bonded	2
48	30156A0202		ANNULUS	2
50	8S04B		BOLT	34
52	30156A0102		DOWEL, 8dia x 60mm	4
53	30082A0418		GEAR, sun	2

212 series

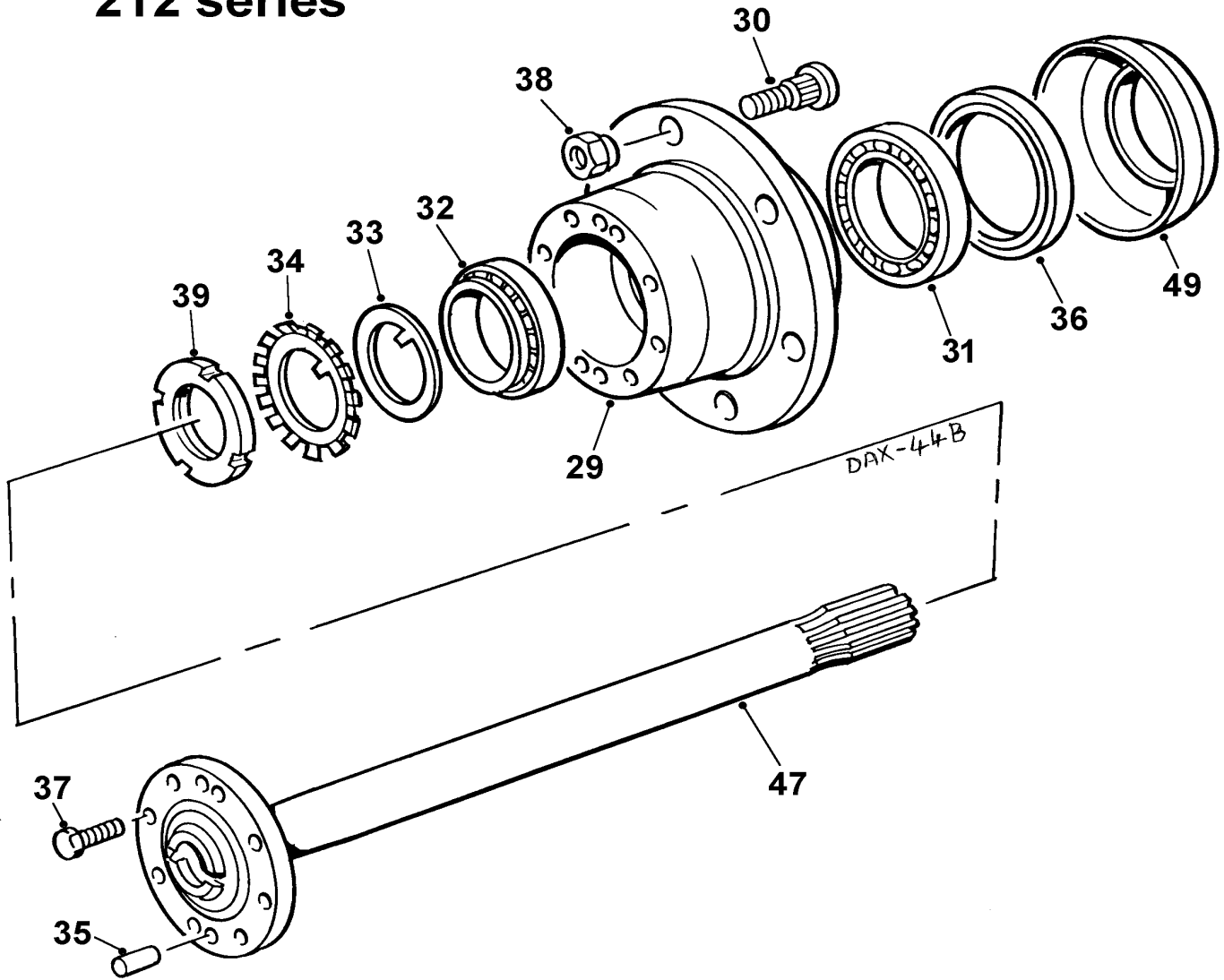

HUB & AXLE SHAFT**B - 10B****Newage 212 series drive axle, (non braked)**

Item	Part no	Axle serial no	Description	Qty
29	30082A0407		HUB	1
30	30156A0122		STUD, wheel	5
31	30082A0408		BEARING	1
32	30082A0409		BEARING	1
33	30082A0222		SPACER	1
34	30347A0201		LOCKWASHER	1
35	30156A0112		DOWEL, spring	2
36	30082A0410		SEAL, oil	1
37	8S04B		BOLT	8
38		NUT, wheel (see " <i>Wheels</i> ", page B-1)
39	30082A0411		LOCKNUT	1
47	30082A0421		SHAFT, axle (1475mm)	2
49	30082A0422		COVER, seal, wheel hub	2

215 series

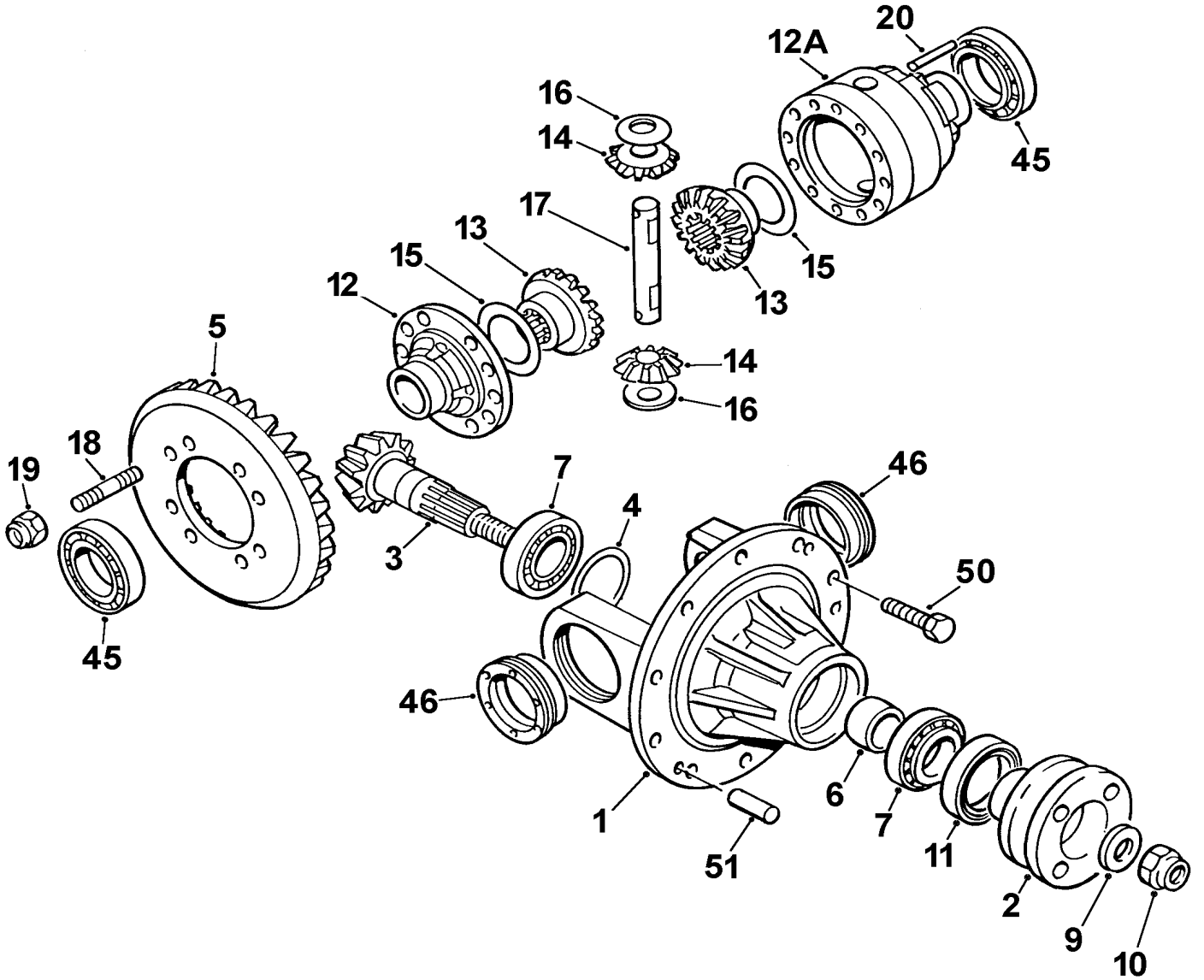

INPUT PINION & DIFFERENTIAL**B - 11****Newage 215 series drive axle, (with brakes)**

Item	Part no	Axle serial no	Description	Qty
1	30082A0401		PINION, input cartridge	1
2	30082A0402		FLANGE, input drive, c/w seal shield	1
3	30082A0403		PINION, supplied with item 5	1
4	30082A0282		SHIM, 0.25mm	2
....	30082A0280		SHIM, 0.3mm	2
....	30082A0281		SHIM, 0.4mm	2
5	30082A0403		CROWN WHEEL & PINION SET	1
6	30082A0235		SPACER	1
7	30082A0234		BEARING, cup & cone assembly	2
....	30082A0274		BEARING, cup	1
....	30082A0273		BEARING, cone	1
9	30082A0231		WASHER, plain	1
10	30082A0232		NUT	1
11	30082A0236		SEAL, oil	2
12	30082A0404		COVER, differential	1
12A	30082A0405		CASING, differential	1
13	30082A0283		WHEEL, differential	2
14	30082A0284		PINION, differential	2
15	30082A0241		WASHER, thrust	2
16	30082A0242		WASHER, thrust	2
17	30082A0303		SPIDER, differential, (half)	1
18	30082A0406		STUD	8
19	59S03		NUT, 'Nyloc'	8
20	30082A0306		PIN, Spirol	2
45	119325000		BEARING, cup & cone assy.	2
46	30082A0416		NUT, bearing adjustment	2
50	8S04B		BOLT	34
51	30156A0112		DOWEL, 10dia x 20mm	2

215 series

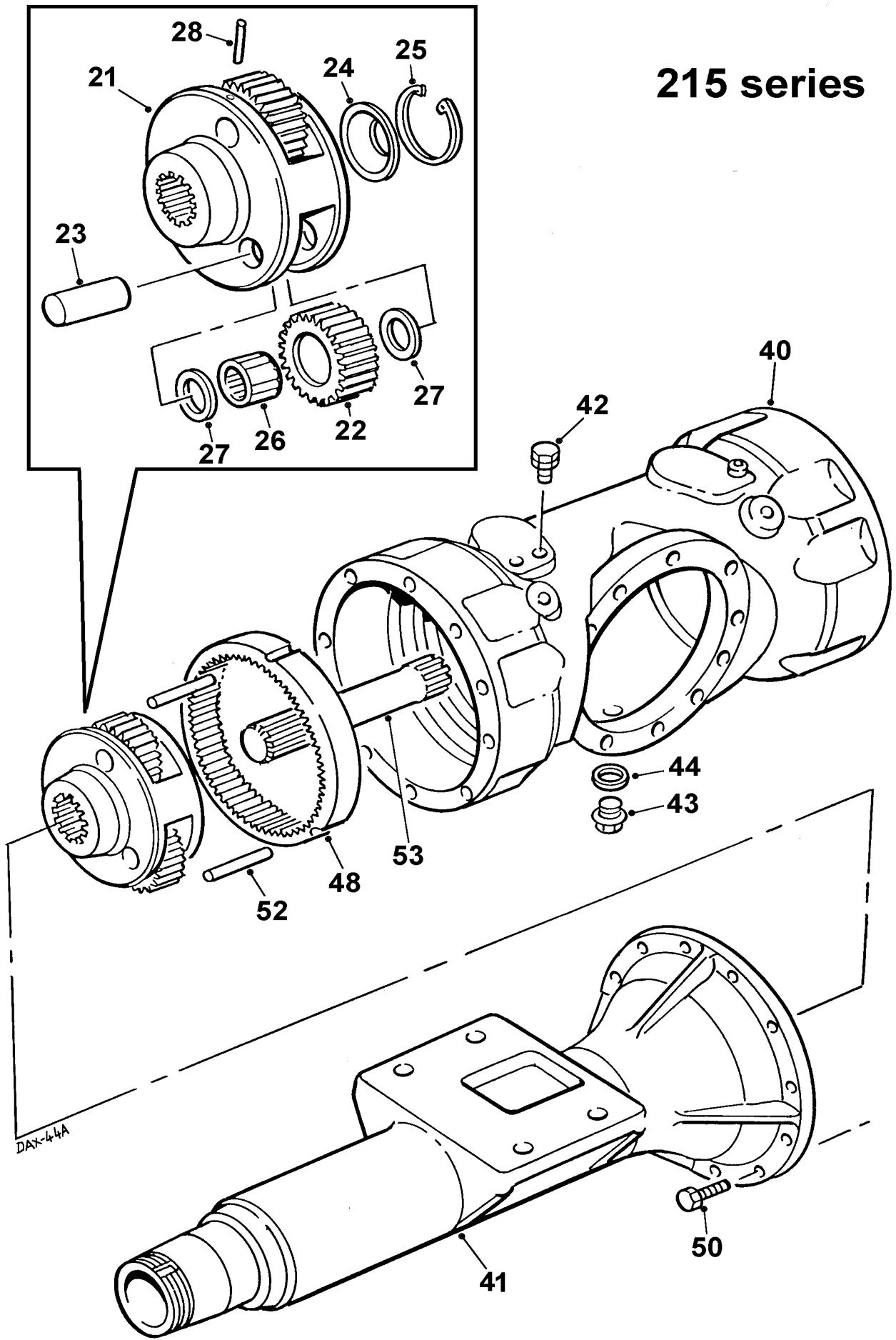

PLANET CARRIER & AXLE CASING
Newage 215 series drive axle, (with brakes)

B - 11A

Item	Part no	Axle serial no	Description	Qty
21	30156A0802		CARRIER, planet	1
22	30156A0803		GEAR, planet	3
23	30156A0804		PIN, planet	3
24	30156A0805		SPACER	1
25	30082A0265		CIRCLIP	1
26	30082A0289		BEARING, needle	3
27	30082A0249		WASHER, thrust	6
28	30156A0162		DOWEL, spring	3
40	30082A0413		CASING, main	1
41	30082A0414		ARM, axle (1475mm)	2
42	30082A0415		BREATHER	1
43	30097A0163		PLUG, drain	2
44	100S04		SEAL, bonded	2
48	30156A0202		ANNULUS	2
50	8S04B		BOLT	34
52	30156A0102		DOWEL, 8dia x 60mm	4
53	30082A0418		GEAR, sun	2

215 series

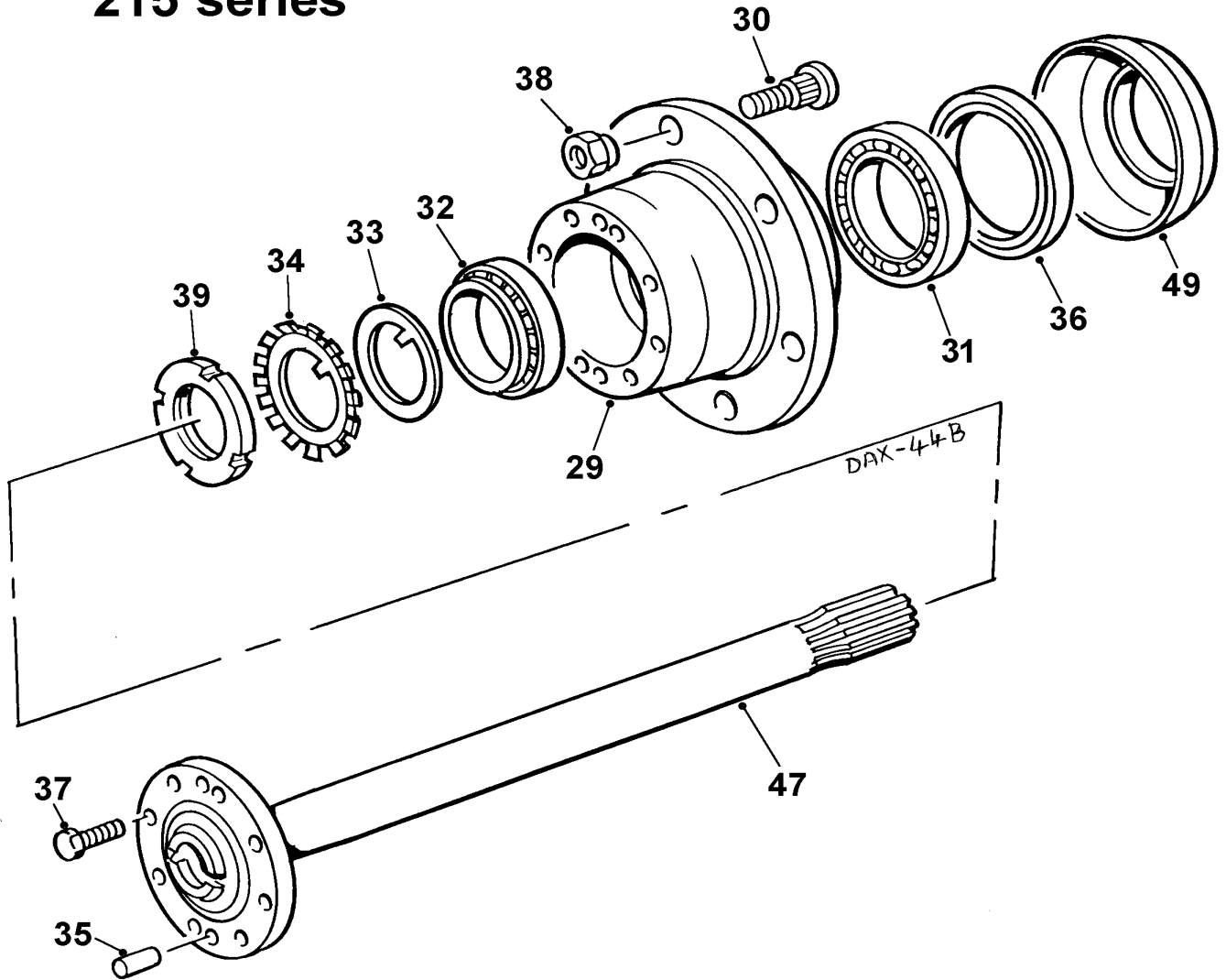

HUB & AXLE SHAFT

B - 11B

Newage 215 series drive axle, (with brakes)

Item	Part no	Axle serial no	Description	Qty
29	30082A0407		HUB	1
30	30156A0122		STUD, wheel	5
31	30082A0408		BEARING	1
32	30082A0409		BEARING	1
33	30082A0222		SPACER	1
34	30347A0201		LOCKWASHER	1
35	30156A0112		DOWEL, spring	2
36	30082A0410		SEAL, oil	1
37	8S04B		BOLT	8
38		NUT, wheel (see "Wheels", page B-1)
39	30082A0411		LOCKNUT	1
47	30082A0417		SHAFT, axle (1475mm)	2
49	30082A0422		COVER, seal, wheel hub	2

215 series

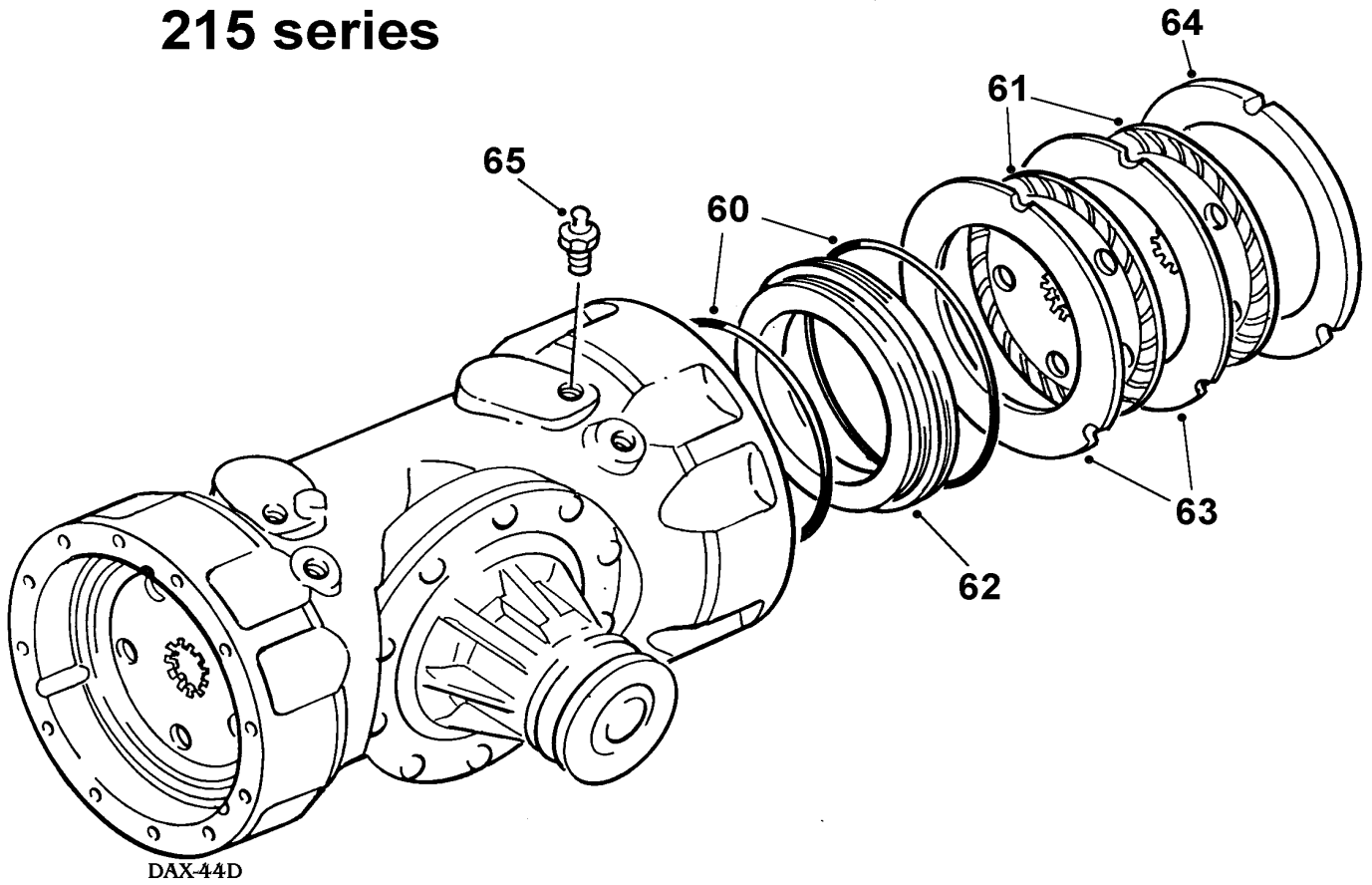

BRAKES**B - 11C****Newage 215 series drive axle, (with brakes)**

Item	Part no	Axle serial no	Description	Qty
60	30156A0108		KIT, 'O' ring seals, brake piston	1
*61	30156A0908		DISC, brake, sintered	4
62	30156A0107		PISTON, brake	2
*63	30156A0909		PLATE, brake, fixed	4
*64	30156A0910		SPACER, brake	2
65	30082A0419		VALVE, brake bleeding	1
*	30156A0911		Kit, brake plates, consisting of items marked *	

Transmission

GEARBOX used with 'Newage' axles	C - 1
GEARBOX used with 'Salisbury' axles	C - 2
CLUTCH & FLYWHEEL	C - 3
PEDAL & ROD, Clutch	C - 4
TRANSFER BOX	C - 5
PROPELLER SHAFTS	C - 6

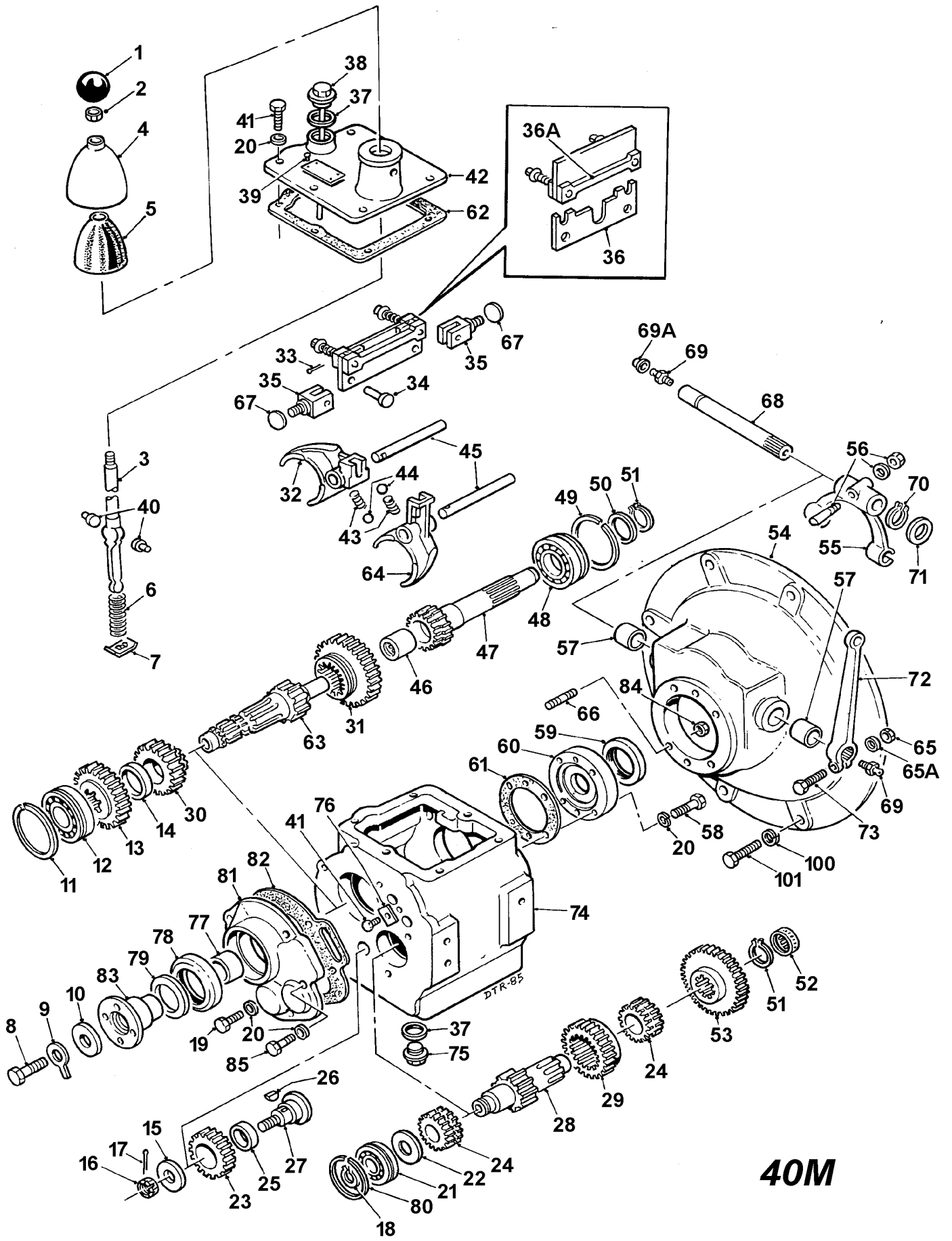

40M

Item	Part no	Serial no	Description	Qty
------	---------	-----------	-------------	-----

\$ From gearbox batch no. B1238.

When replacing layshaft 30101A0223 on gearboxes prior to batch no B1238, layshaft assembly 30101A0268 should be ordered.

This replaces the previous layshaft 30101A0223 and bush 30101A0244.

(Gearbox oil capacity becomes 2 litres - previously .85 litres).

From gearbox serial no. 0155335 (Apr 1993)

Needle roller bearing (item 52) changed from an imperial to a metric dimension.

This change also affects the Layshaft (item 28) and Casing (item 74).

See *Layshaft Kit (item 28)*

-	30101A03	/ Jun-86	GEARBOX, assembly, Petter engine (with straight gear lever)	1
-	30101A02	/ Jun-86	GEARBOX, assembly, Lister engine (with straight gear lever)	1
-	30101A09	JUN 86/	GEARBOX, assembly (with cranked gear lever)	1
1	30101A0201		KNOB, gear lever	1
2	95S03		NUT, locking	
3	20097A07	/ Jun-86	LEVER, gear, straight, Lister engine	1
3	20097A06	/ Jun-86	LEVER, gear, straight, Petter engine	1
3	30101A0901	JUN 86/	LEVER, gear, cranked	1
4	30101A0203		CAP, gear lever	1
5	30101A0204		COVER, gear lever	1
6	30101A0205		SPRING, gear lever	1
7	30101A0206		PLATE, gear lever retaining	1
8	28S05E		BOLT	1
9	30101A0207		WASHER, tab	1
10	30101A0208		WASHER	1
11	30101A0209		RING, snap	1
12	88S06E		BEARING, mainshaft, rear	1
13	30101A0211		GEAR, output	1
14	30101A0212		SPACER, output gear	1
15	30101A0213		WASHER, reverse pinion shaft	1
16	102S04		NUT, slotted	1
17	44S02C		PIN, split	1
18	30218A0206		CIRCLIP	1

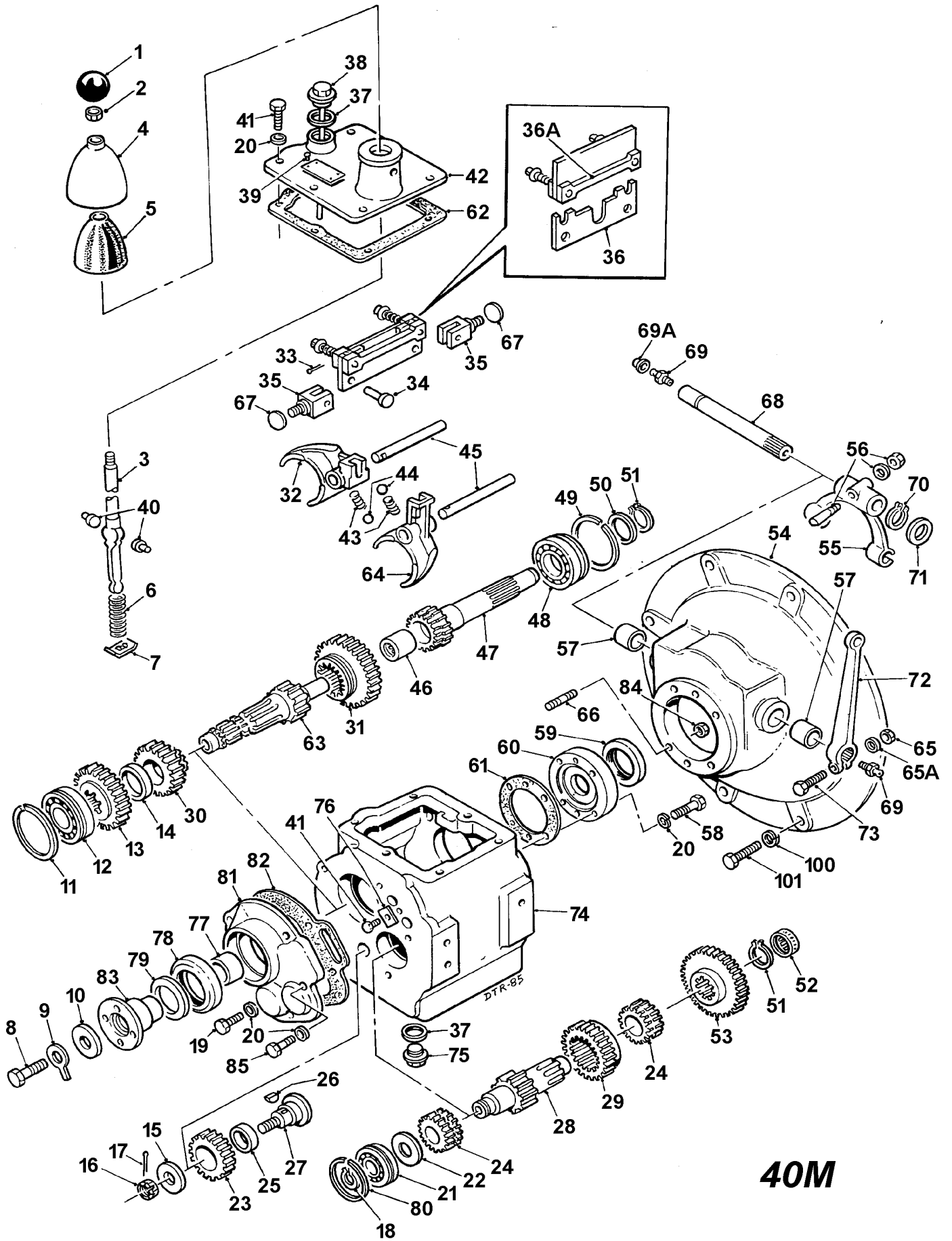

40M

GEARBOX (with Newage axle)

C - 1

Item	Part no	Serial no	Description	Qty
19	28S01D		BOLT	3
20	30039A0169		WASHER, 'Nyltite'	9
21	30101A0216		BEARING, layshaft	1
22	30101A0217		SPACER, bearing	1
23	30101A0218		PINION, reverse	2
24	30101A0219		GEAR, reverse speed	2
25	30101A0220		BUSH, reverse pinion	1
26	30101A0221		KEY, reverse pinion shaft	1
27	30101A0222		SHAFT, reverse pinion	1
28	30101A0223	/ \$	LAYSHAFT	1
28	30101A0268	\$ / 0155334 #	LAYSHAFT, Kit (<i>Imperial</i>) (<i>Kit includes items: 28, 37, 38, 52</i>)	1
28	30101A0280	0155335 /	# LAYSHAFT, (<i>Metric</i>)	1
29	30101A0224		GEAR, 2nd speed, sliding	1
30	30101A0225		GEAR, 2nd speed	1
31	30101A0226		GEAR, 1st speed	1
32	30101A0227		FORK, 2nd & 3rd selector	1
33	44S02C		PIN, split, interlock	2
34	30101A0228		PIN, clevis, interlock	2
35	30101A0229		STUD, interlock	2
36	30101A0230		PLATE, interlock	1
37	30101A0231		WASHER, sealing	2
38	30101A0232	/ \$	DIPSTICK, 163mm rod	1
38	30218A0223	\$ / 0155334	DIPSTICK, 93mm rod	1
38	30218A0248	0155335 /	# DIPSTICK, 137mm rod	1
39	30101A0233		SCREW, drive	4
40	30101A0234		PAD, gear lever	2
41	28S01C		BOLT	7
42	30101A0235		COVER, top	1
43	30097A0185		SPRING, detent	2
44	30097A0199		BALL, detent	2
45	30101A0237		SHAFT, selector	2
46	30101A0238		BEARING, primary shaft (<i>part of iter.</i>)	1
47	30101A0239		SHAFT, primary (<i>with item 46</i>)	1
48	30101A0240		BEARING, input	1
49	30101A0241		RING, snap	1
50	30101A0242		SPACER, bearing	1
51	30101A0243		CIRCLIP	2
52	30101A0244	/ \$	BUSH, layshaft	1
52	30101A0267	\$ / 0155334 #	BEARING (<i>Imperial</i>), layshaft	1
52	30101A0279	0155335 /	# BEARING (<i>Metric</i>), layshaft	1

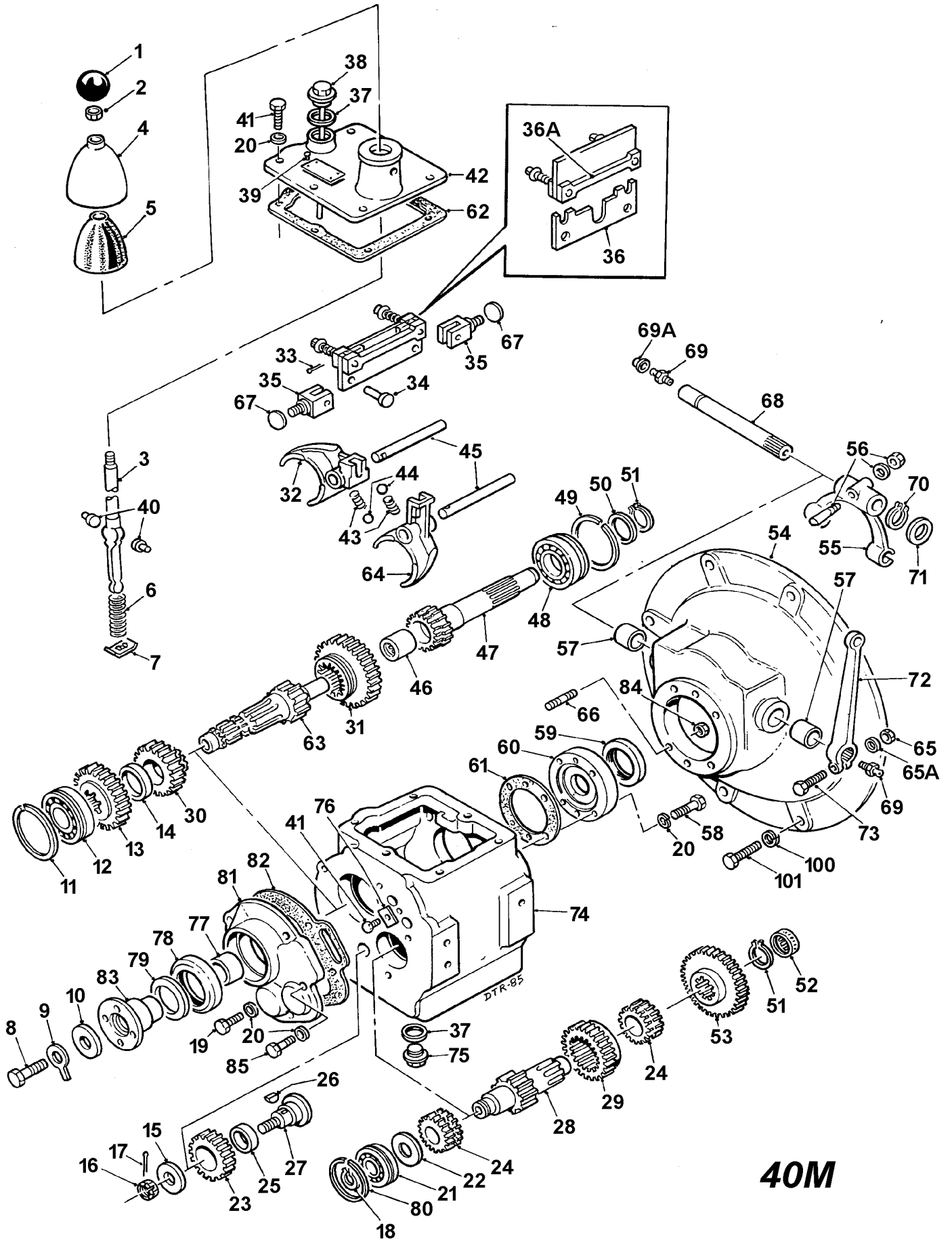

40M

GEARBOX (with Newage axle)

C - 1

Item	Part no	Serial no	Description	Qty
53	30101A0245		GEAR, 1st reduction	1
54	30101A0246		HOUSING, clutch	1
55	30097A0110		FORK, clutch release	1
56	30097A0111		NUT, WASHER & COTTER PIN	1
57	30097A0114		BUSH, cross shaft	2
58	6S01A		BOLT, front cover	4
59	30101A0247		SEAL, oil (<i>part of item 60</i>)	1
60	30101A0248		COVER, front (<i>with item 59</i>)	1
61	30101A0249		GASKET, front cover	1
62	30101A0250		GASKET, top cover	1
63	30101A0251		SHAFT, main	1
64	30101A0252		FORK, selector, 1st & reverse	1
65	9S01		NUT, clutch lever	1
65A	67S01		WASHER, use 30039A0169	1
65A	30039A0169		WASHER	1
66	30101A0253		STUD, clutch housing	6
67	30101A0254		PLUG	3
68	30101A0255		SHAFT, cross, clutch	1
69	131S06		NIPPLE, grease	2
70	30101A0256		CIRCLIP	1
71	30097A0133		WASHER, cross shaft	1
72	30097A0109		LEVER, clutch release	1
73	6S01C		BOLT, clutch lever	1
74	30101A0258	/ 0155334 #	CASING, gearbox	1
74	30101A0281	0155335 / #	CASING, gearbox	1
75	30097A0163		PLUG, drain	1
76	30101A0259		STRIP, selector locking	1
77	30101A0260		SPACER	1
78	89S02		SEAL, oil, rear	1
79	30101A0265		SHIELD, dust (<i>part of item 83</i>)	1
80	30101A0261		RING, snap	1
81	30101A0262		COVER, output	1
82	30101A0263		GASKET, output cover	1
83	30101A0264		FLANGE "1310" output (<i>see item 79</i>)	1
84	107S03		NUT, clutch housing	6
85	6S01B		BOLT	2
90	44S01C		PIN, split	2
100	41S05		WASHER, spring, Imperial	8
100	17S05		WASHER, spring, Metric	8
101	66S03A		BOLT, gearbox- <i>Lister engine, UNC</i>	8
101	11S04C		BOLT, gearbox- <i>Lister engine, Metric</i>	8
101	3S03E		BOLT, gearbox- <i>Petter engine, Imperial</i>	8

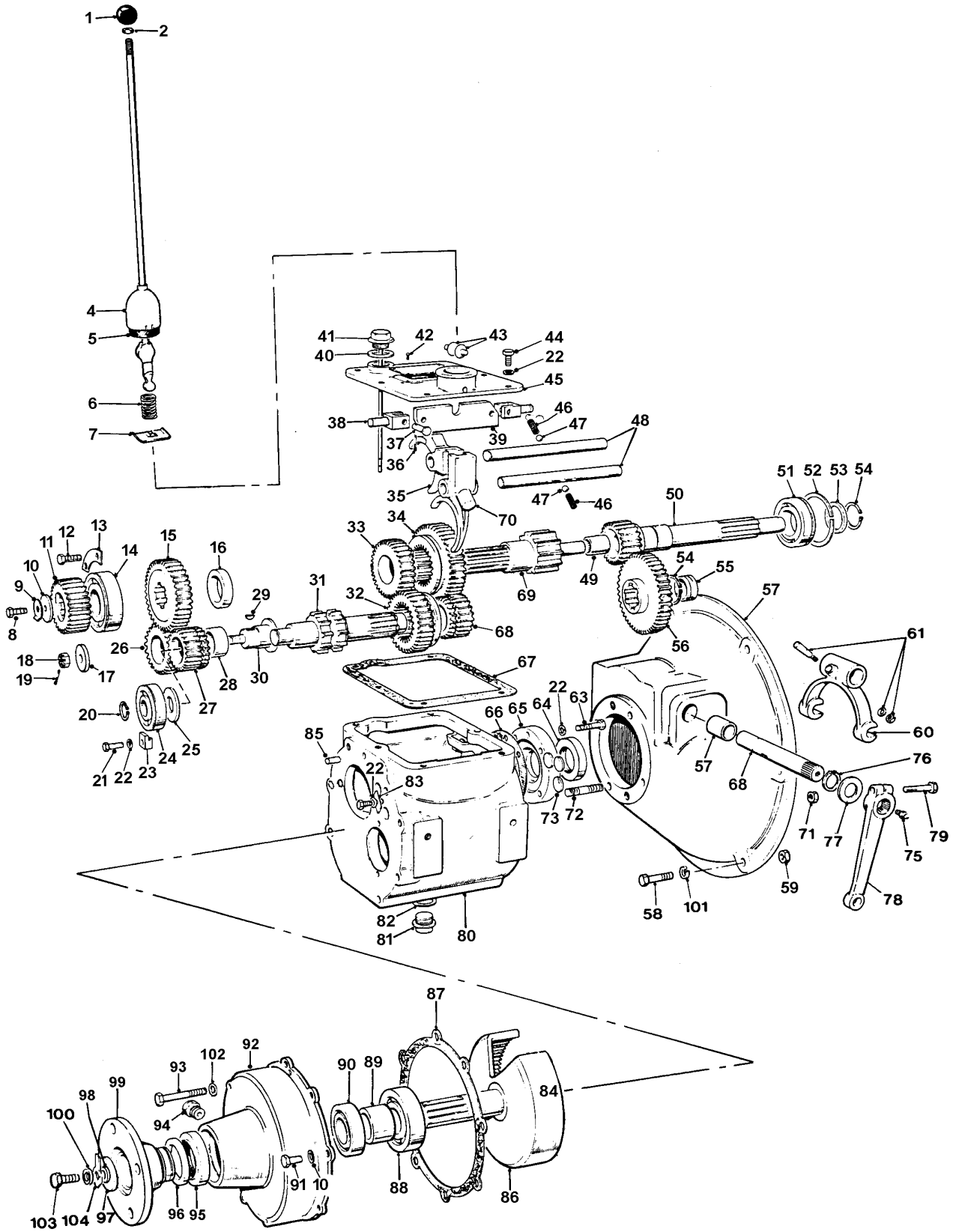

Item	Part no	Serial no	Description	Qty
\$ From gearbox batch no. B1238.				
When replacing layshaft 30101A0223 on gearboxes prior to batch no B1238, layshaft assembly 30101A0268 should be ordered.				
This assembly consists of layshaft 30101A0266 and bearing 30101A0267, and replaces the previous assembly of layshaft 30101A0223 and bush 30101A0244.				
The two layshaft assemblies are interchangeable.				
(New gearbox oil capacity now 2 litres - previously .85 litres).				
-	30190A01	/ Jun-86	GEARBOX, assembly, Lister engine (with straight gear lever)	1
-	30190A02	/ Jun-86	GEARBOX, assembly, Petter engine (with straight gear lever)	1
-	30190A06	JUN 86/	GEARBOX, assembly (with cranked gear lever)	1
-	20097A07	/ Jun-86	LEVER, gear, straight, Lister eng.	1
-	20097A06	/ Jun-86	LEVER, gear, straight, Petter eng.	1
-	30101A0901	JUN 86/	LEVER, gear, cranked	1
1	30101A0201		KNOB, gear lever	1
2	95S03		NUT, locking	
4	30101A0203		CAP, gear lever	1
5	30101A0204		COVER, gear lever	1
6	30101A0205		SPRING, gear lever	1
7	30101A0206		PLATE, gear lever retaining	1
8	28S03E		SCREW, mainshaft	1
9	30190A0101		WASHER, tab	1
10	30190A0102		WASHER, reduction pin	1
11	30190A0103		PINION, reduction	1
12	28S01B		SCREW, bearing retainer	2
13	30190A0104		RETAINER, bearing	1
14	30101A0210		BEARING, mainshaft, rear	1
15	30101A0211		GEAR, output	1
16	30101A0212		SPACER, output gear	1
17	30101A0213		WASHER, reverse pinion shaft	1
18	102S04		NUT, castle, reverse spindle	1
19	44S02C		PIN, split	1
20	30101A0215		CIRCLIP	1
21	28S01D		SCREW	2
22	67S01		WASHER, shakeproof	12
23	30190A0105		CLIP, layshaft bearing	2
24	30101A0216		BEARING, layshaft	1
25	30101A0217		SPACER, bearing	1
26	30101A0218		PINION, reverse	2

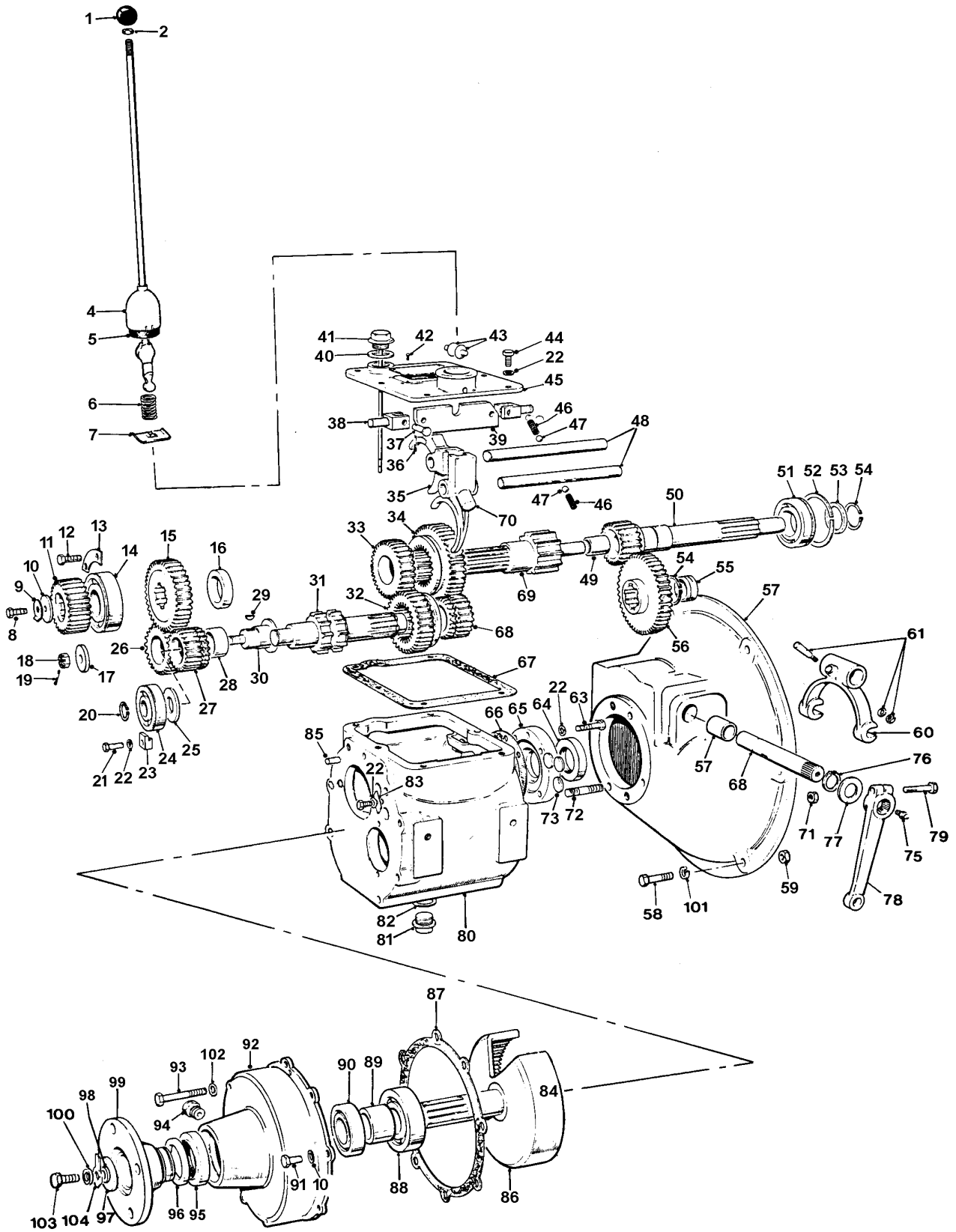

GEARBOX (with Salisbury axle)**C - 2**

Item	Part no	Serial no	Description	Qty
27	30101A0219		GEAR, reverse speed	2
28	30101A0220		BUSH, reverse pinion	1
29	30101A0221		KEY, reverse pinion shaft	1
30	30101A0222		SHAFT, reverse pinion	1
31	30101A0223	/ \$	LAYSHAFT	1
31	30101A0266	\$ /	LAYSHAFT	1
32	30101A0224		GEAR, 2nd speed, sliding	1
33	30101A0225		GEAR, 2nd speed	1
34	30101A0226		GEAR, 1st speed	1
35	30101A0227		FORK, 2nd & 3rd selector	1
36	44S01C		PIN, split, interlock	2
37	30101A0228		PIN, clevis, interlock	2
38	30101A0229		STUD, interlock	2
39	30101A0230		PLATE, interlock	1
40	30101A0231		WASHER, sealing	2
41	30101A0232	/ \$	DIPSTICK	1
41	30218A0223	\$ /	DIPSTICK	1
42	30101A0233		SCREW, drive	4
43	30101A0234		PAD, gear lever	2
44	28S01C		BOLT	7
45	30101A0235		COVER, top	1
46	30097A0185		SPRING, detent	2
47	30101A0236		BALL, detent	2
48	30101A0237		SHAFT, selector	2
49	30101A0238		BEARING, primary shaft	1
50	30101A0239		SHAFT, primary	1
51	30101A0240		BEARING, input	1
52	30101A0241		RING, snap	1
53	30101A0242		SPACER, bearing	1
54	30101A0243		CIRCLIP	2
55	30101A0244	/ \$	BUSH, layshaft	1
55	30101A0267	\$ /	BEARING, layshaft	1
56	30101A0245		GEAR, 1st reduction	1
57	30101A0246		HOUSING, clutch	1
58			SCREW, set, clutch housing	8
59	30190A0116		NUT, nylon insert	6
60	30097A0110		FORK, clutch release	1
61	30097A0111		COTTER PIN, NUT & WASHER	1
62	30097A0114		BUSH, cross shaft	2
63	6S01B		BOLT, front cover	4
64	30101A0247		SEAL, oil	1
65	30101A0248		COVER, front	1
66	30101A0249		GASKET, front cover	1

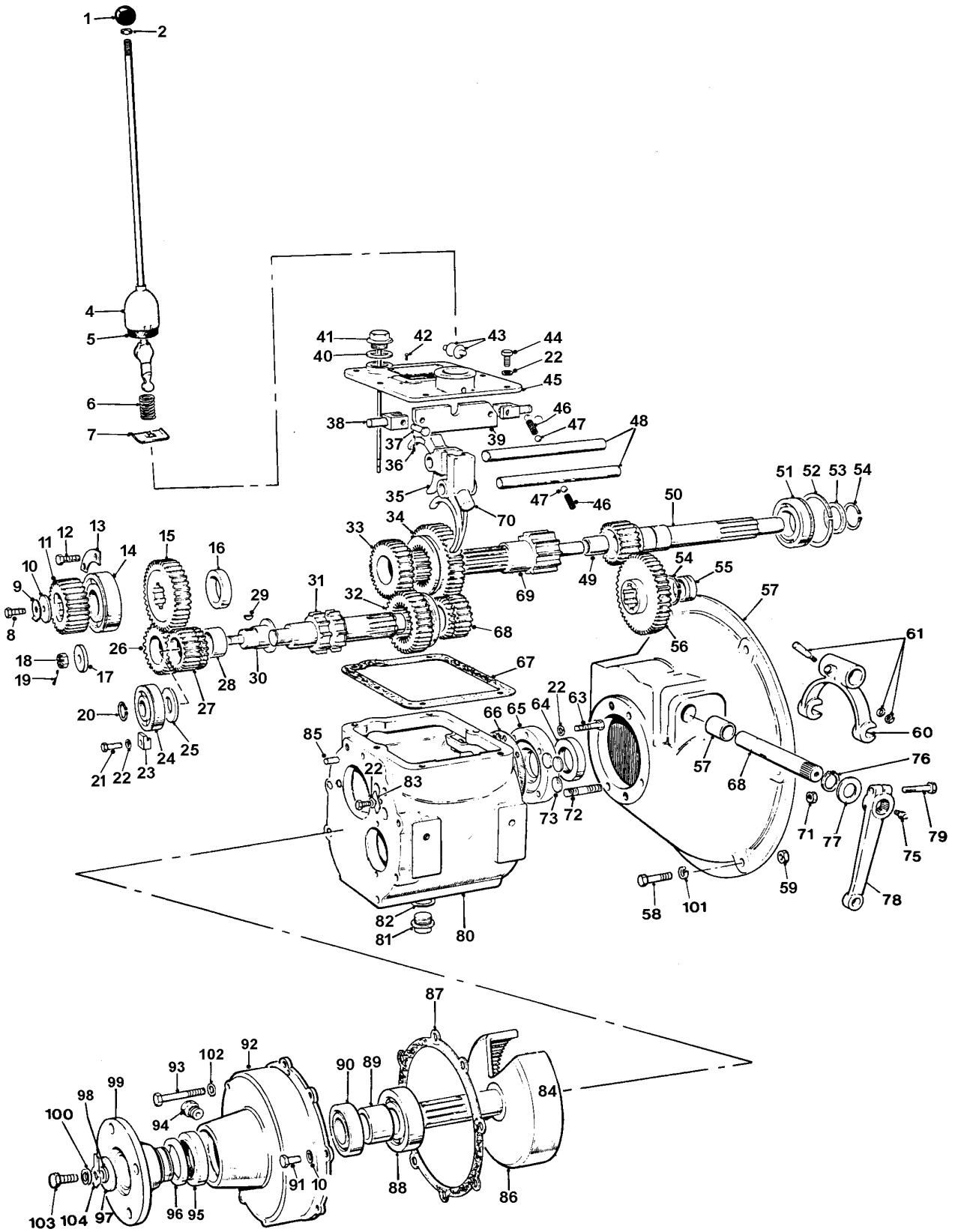

GEARBOX (with Salisbury axle)**C - 2**

Item	Part no	Serial no	Description	Qty
67	30101A0250		GASKET, top cover	1
68	30101A0219		GEAR, reverse speed	1
69	30190A0106		SHAFT, main	1
70	30101A0252		FORK, selector, 1st & reverse	1
71	9S01		NUT, clutch lever	1
72	30101A0253		STUD, clutch housing	6
73	30101A0254		PLUG	3
74	30101A0255		SHAFT, cross, clutch	1
75	131S01		NIPPLE, grease	2
76	30101A0256		CIRCLIP	1
77	30101A0257		WASHER, cross shaft	1
78	30097A0109		LEVER, clutch release	1
79	6S01C		BOLT, clutch lever	1
80	30190A0107		CASING, gearbox	1
81	30190A0108		PLUG, drain	1
82	42S05		SEAL, drain plug	1
83	30101A0259		STRIP, selector locking	1
84	28S01C		SCREW, set	2
85	30097A0155		DOWEL	2
86	30190A0110		GEAR, internal	1
87	30190A0112		JOINT, reduction housing	1
88	30190A0111		BEARING, internal gear front	1
89	30101A0260		SPACER	1
90	30190A0113		BEARING, internal gear rear	1
91	28S02D		SCREW	4
92	30190A0114		HOUSING, reduction	1
93	6S02J		BOLT	4
94	30097A0171		BREATHER	1
95	30097A0132		SEAL, oil, rear	1
96	30101A0265		SHIELD, dust	1
97	30101A0208		WASHER, coupling	1
98	30101A0207		WASHER, locking	1
99	30101A0264		COUPLING, "1310"	1
100	28S05E		SCREW, coupling	1
101	41S05		WASHER, spring	8
102	41S04		WASHER, spring	8
103	30143A0111		WASHER, fibre	1
104	30143A0101		WASHER, fibre	1
	- 69S03E		BOLT, gearbox to <i>Lister engine</i>	8
	- 3S03E		BOLT, gearbox to <i>Petter engine</i>	8

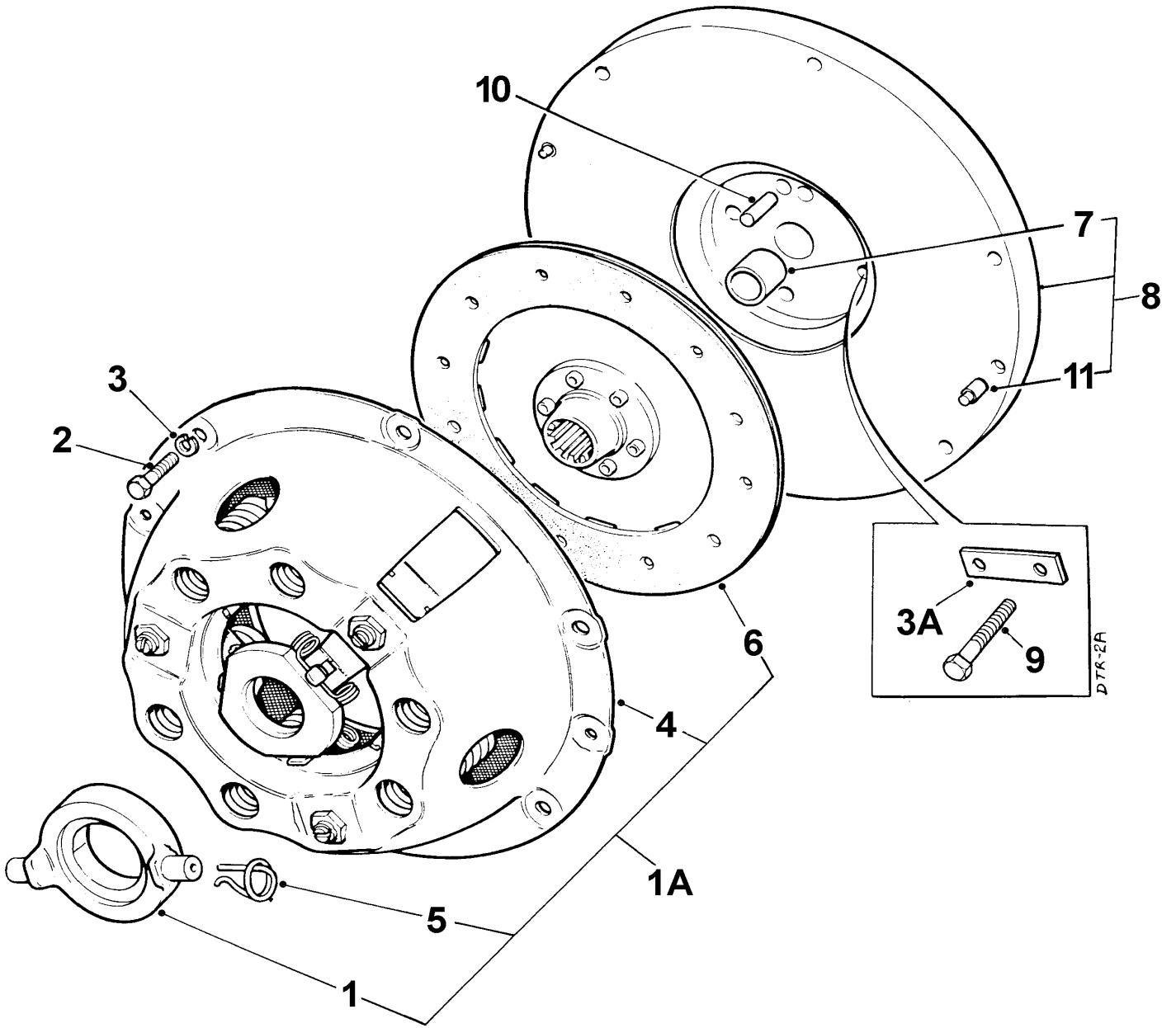

Item	Part no	Serial no	Description	Qty
1A	10948A02		KIT, 8" clutch (<i>comprises of items marked #</i>)	1
1	10579A01		# BEARING, clutch release	1
2	28S02D		SCREW, set, <i>not Petter P600/2</i>	6
2	11S03B		SCREW, set, Petter P600/2	6
3	41S04		WASHER, spring, <i>not Petter P600/2</i>	10
3	17S04		WASHER, spring, Petter P600/2	6
3A	10531A02		WASHER, tab, 70mm long, Lister	1
3A	10531A03		WASHER, tab, 60mm long, Lister	1
3A	10531A03		WASHER, tab, Petter P600/2	2
4	10597A01		# COVER, clutch, <i>not Petter P600/2</i>	1
4	10597A02		COVER, clutch, Petter P600/2	1
5	10579A0101		# SPRING, retaining	2
6	10598A02		# PLATE, clutch, <i>not Petter P600/2</i>	1
6	10598A03		PLATE, clutch, Petter P600/2	1
7	10580A0101		BUSH	1
8	10580A02		FLYWHEEL, assy. (<i>c/w items 7 & 11</i>)	1
9	1S02C		BOLT, Petter PH2	4
9	6S02B		BOLT, Lister ST2	4
9	8S03B		BOLT, Lister TS2, Petter P600/2	4
10	C321		DOWEL	1
11	10580A0102		DOWEL	2

Option from January 2000

1A	10948A03	Jan-00 /	KIT, 9" clutch (<i>comprises of items marked \$</i>)	
1	10579A01		\$ BEARING, clutch release	1
2	28S02D		SCREW, set	6
3	41S04		WASHER, spring	6
3A	10531A02		WASHER, tab, 70mm long	1
3A	10531A03		WASHER, tab, 60mm long	1
4	10597A02		\$ COVER	1
5	10579A0101		\$ SPRING, retaining	2
6	10598A03		\$ PLATE, driven	1
7	10580A01		FLYWHEEL, assy. (<i>c/w items 8 & 9</i>)	1
8	10580A0101		BUSH	1
9	10580A0102		DOWEL	1
10	C321		DOWEL	1
11	8S03B		BOLT	4

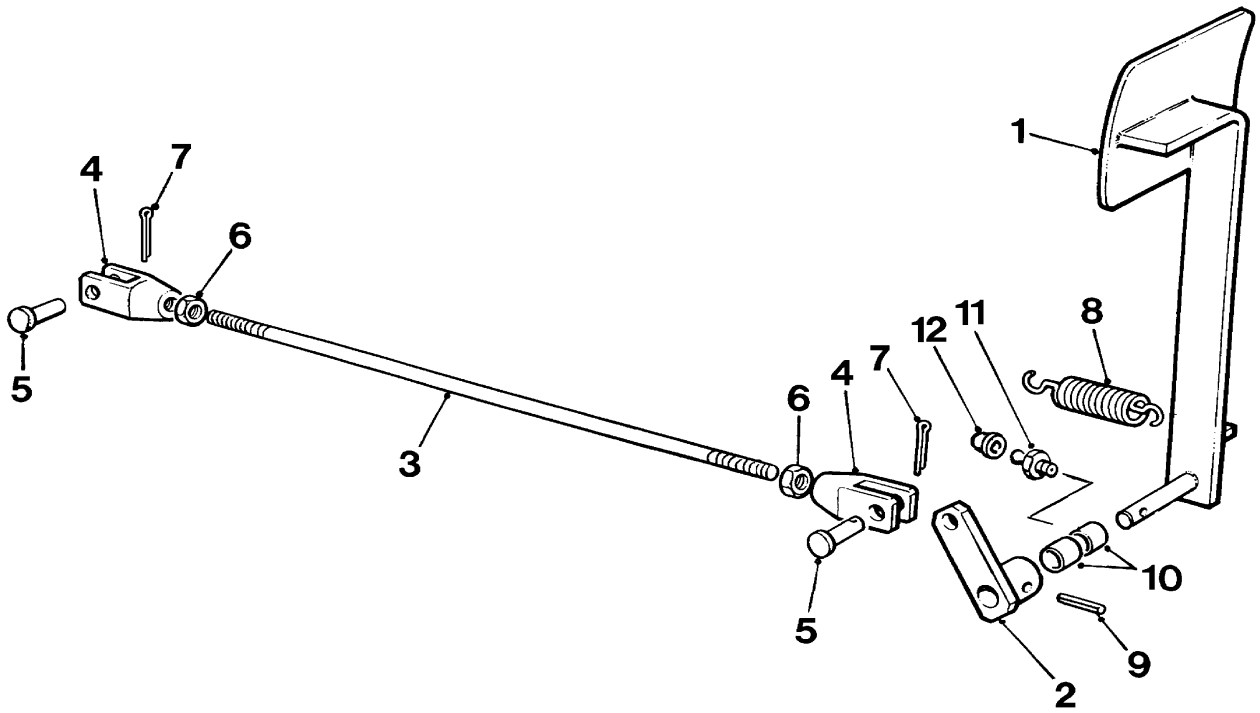

PEDAL & ROD, CLUTCH**C - 4**

Item	Part no	Serial no	Description	Qty
1	20096A05		PEDAL, clutch	1
2	10563A02		LEVER, clutch	1
3	40SC23		ROD, clutch (UNF 3/8")	1
3	38SC50		ROD, clutch (BSF 3/8")	1
4	C174J		CLEVIS (UNF 3/8")	2
4	C174A		CLEVIS (BSF 3/8")	2
5	10650A17		PIN, clevis	2
6	95S03		NUT, locking (UNF 3/8")	2
6	2S04		NUT, locking (BSF 3/8")	2
7	44S02C		PIN, split	2
8	C173B		SPRING	1
9	54S07M		PIN, tension	1
10	43S02		BUSH	2
11	131S01		NIPPLE, grease	1
12	176S01		CAP, grease nipple	1

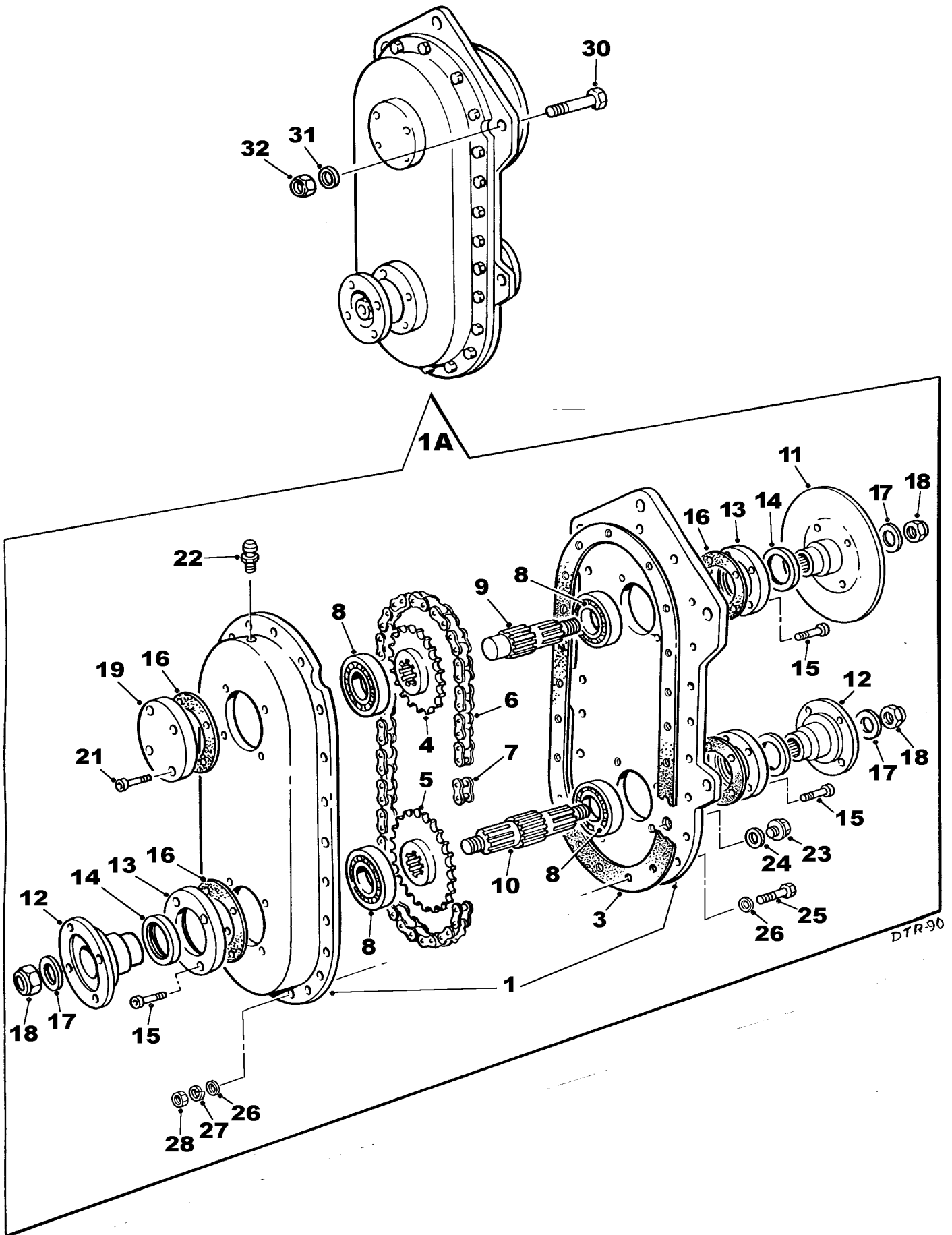

TRANSFER BOX

C - 5

Item	Part no	Serial no	Description	Qty
1A	40098A02		TRANSFER BOX, assembly	1
1	43596		CASE & COVER, assembly	1
3	43520		GASKET	1
4	10294A02		SPROCKET, 19T, top	1
5	10294A03		SPROCKET, 25T, bottom	1
6	80S03		CHAIN, roller, 3/4" pitch, simplex	1
7	81S02		LINK, chain connection	1
8	88S06		BEARING	4
9	10299A01		SHAFT, input	1
10	10300A01		SHAFT, output	1
11	20109A01		FLANGE, input, c/w brake disc	1
12	10384A01		FLANGE, output	2
13	10562A01		HOUSING, oil seal	3
14	89S02		SEAL, OIL	3
15	90S02H		SCREW, cap	12
16	10293A01		GASKET	4
17	10S06		WASHER	3
18	107S07		NUT, locking	3
19	10298A01		COVER, end	1
21	6S01A		BOLT, hex. Head	4
.....	10S01		WASHER, flat (<i>used with hex. bolt</i>)	4
			<i>or</i>	
21	90S02H		SCREW, cap	4
22	10305A01		BREATHER	1
23	10301A01		PLUG, level/filler	1
24	42S05		WASHER, fibre	1
25	8S02C		BOLT	24
26	267S04		WASHER, flat	24
27	17S03		WASHER, spring	24
28	7S02		NUT	24
30	11S05D		SCREW, set	4
31	267S07		WASHER, flat	4
32	61S05		NUT, locking	4

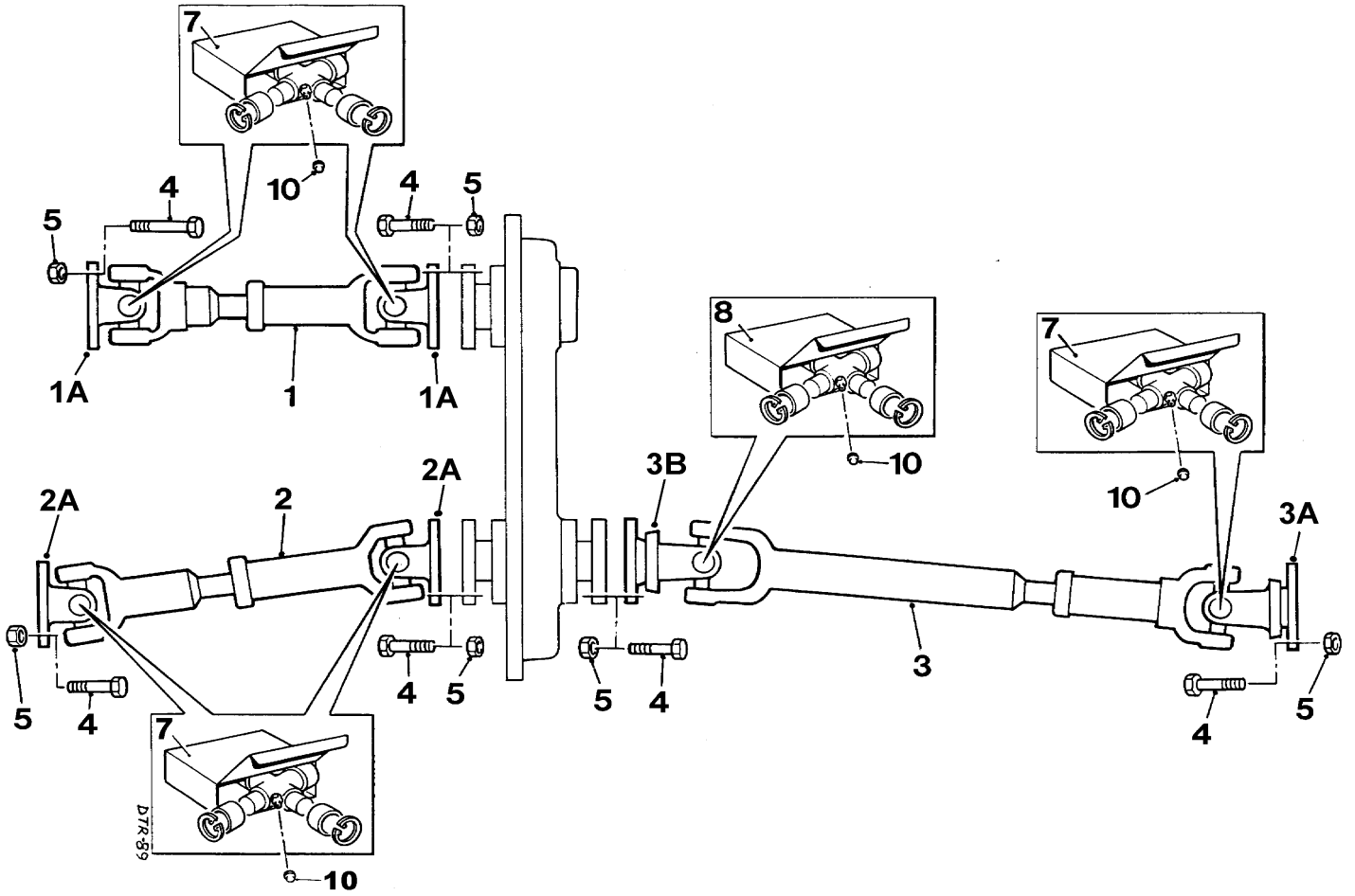

Item	Part no	Serial no	Description	Qty
Machines with Salisbury axles				
1	20086A01		PROPSHAFT, g/box to trans/box	1
2	20089A01		PROPSHAFT, trans/box to rear axle	1
2A	V602297		YOKE	2
3	30096A01		PROPSHAFT, trans/box to front axle	1
4	10365A02		BOLT, obsolete use: 6S03A	24
4	6S03A		BOLT	24
5	87S03		NUT, self locking	24
.....	41S05		WASHER, spring (<i>under bolt head</i>)	24
7	10568A01		KIT, U.J. repair	AR
8	10568A01		KIT, U.J. repair	AR

Machines with Newage axles

1	20087A01		PROPSHAFT, g/box to trans/box	1
1A	V602297		YOKE	2
2	20088A01		PROPSHAFT, trans/box to rear axle	1
2A	V602297		YOKE	2
3	30095A02		PROPSHAFT, trans/box to front axle (HT/HD/RS)	1
3	30095A03		PROPSHAFT, trans/box to front axle (HRS skip)	1
3A	V602297		YOKE, standard	1
3B	V602301		YOKE, wide angle	1
4	6S03A		BOLT	24
5	107S14		NUT, self locking	24
7	10568A01		KIT, U.J. repair 83mm 1310 Series	AR
8	10568A03		KIT, U.J. repair 75mm 1300 Series	AR
			Check the UJ size across the bearing caps when ordering replacements	
10	176S01		CAP, grease nipple	9

Brakes

HANDBRAKE	D - 1
------------------	--------------

CALIPER, handbrake	D - 2
---------------------------	--------------

BRAKE PEDAL	D - 3
--------------------	--------------

CALIPER, Footbrake Salisbury axle with dry disc brakes	D - 4
---	--------------

BRAKING SYSTEMS

SALISBURY (front axle braking only), with oil immersed brakes	D - 5
--	--------------

NEWAGE, front & rear braking <i>Up to serial number 1092</i>	D - 6
--	--------------

NEWAGE, front & rear braking <i>From serial number 1093</i>	D - 6A
---	---------------

NEWAGE, front braking only <i>Up to serial number 1092</i>	D - 7
--	--------------

NEWAGE, front braking only <i>From serial number 1093</i>	D - 7A
---	---------------

SALISBURY, front axle with dry disc brakes	D - 8
---	--------------

MASTER CYLINDER, Salisbury axles

Dry disc brakes	D - 9
------------------------	--------------

Oil immersed brakes	D - 10
----------------------------	---------------

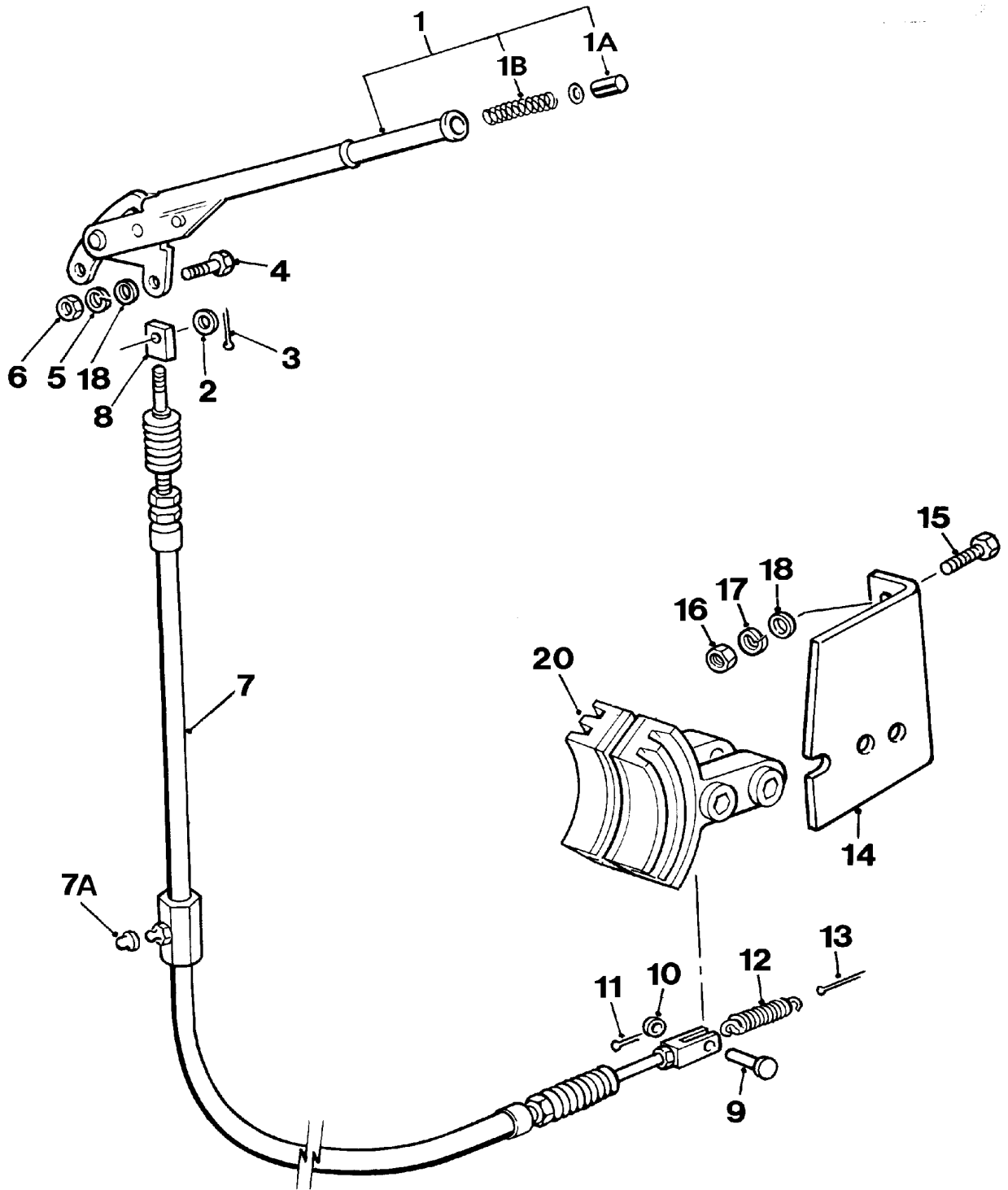

HANDBRAKE**D - 1**

Item	Part no	Serial no	Description	Qty
1	20208A01		LEVER, handbrake	1
1A	20208A0101		BUTTON	1
1B	20208A0102		SPRING	1
2	10S14		WASHER, flat	1
3	44S02B		PIN, split	1
4	11S04C		SCREW, set	2
5	17S05		WASHER, spring	2
6	7S04		NUT	2
7	10367A03		CABLE (<i>includes items 9, 10, 11</i>)	1
7A	176S01		COVER, grease nipple	1
8	L309		BLOCK	1
9	10650A13		PIN, clevis (<i>part of item 7</i>)	1
10	10S01		WASHER, flat (<i>part of item 7</i>)	1
11	44S01C		PIN, split (<i>part of item 7</i>)	1
12	C173D		SPRING, return	1
13	44S05E		PIN, split, return spring	1
14	20191A04		BRACKET, caliper support	1
15	11S04C		SCREW, set	2
16	7S04		NUT	2
17	17S05		WASHER, spring	2
18	267S06		WASHER, flat	4
20	10578A01		CALIPER (<i>see page D-2</i>)	1

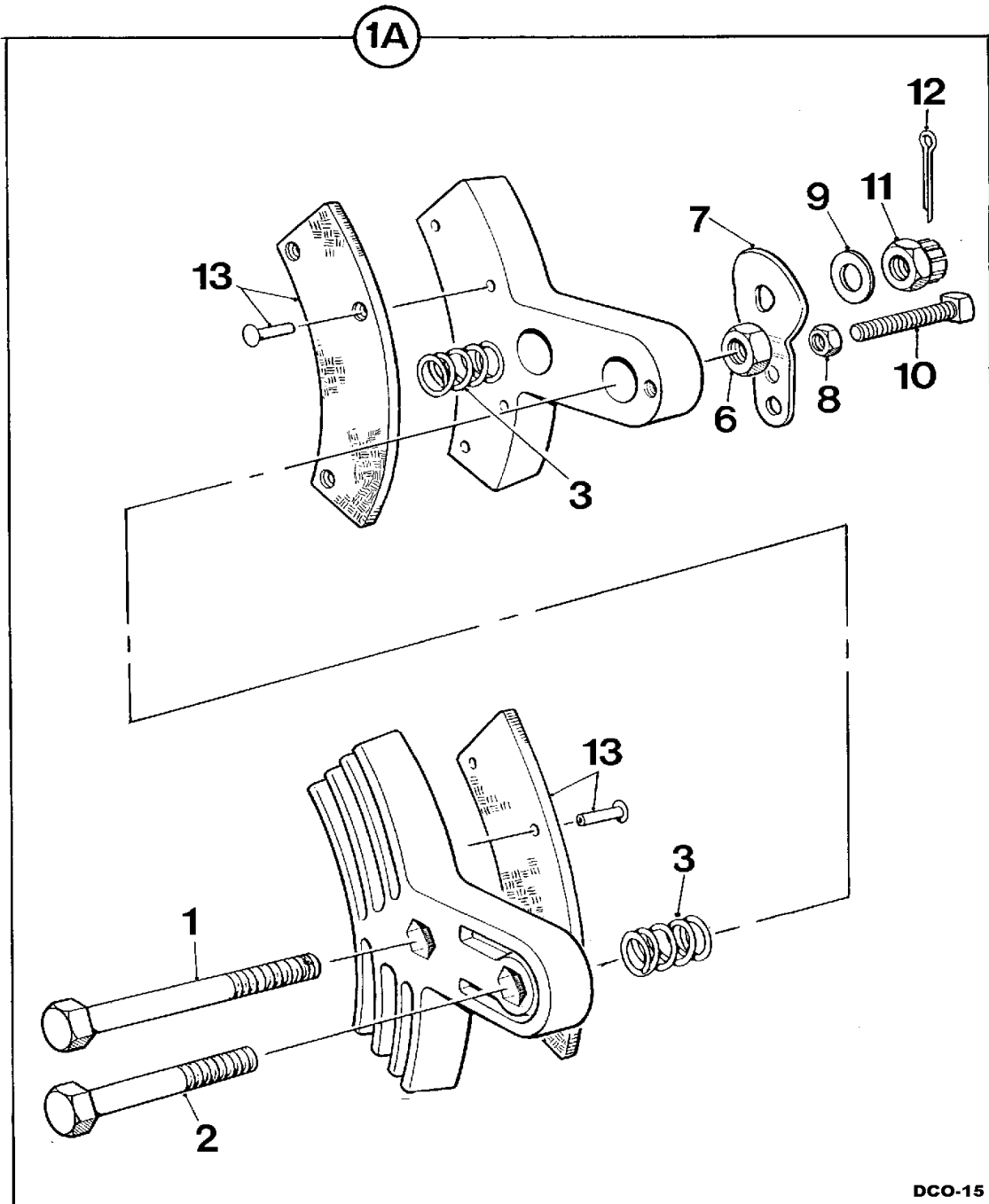

Item	Part no	Serial no	Description	Qty
ALLOY CALIPERS				
1A	10578A01		CALIPER, one pair, assembly	1
1	11116		SCREW, with hole for pin, item 12	1
2	28S02P		SCREW	1
3			TENSION WASHER (obsolete)	
3	10578A0101		<i>use</i> SPRING, centring	4
6	9S02		NUT	1
7	10578A0104		CAM	1
8	230S01		NUT, locking	1
9	10578A0105		WASHER	1
10	66S01H		SCREW, set	1
11	227S02		NUT, castle	1
12	44S01C		PIN, cotter	1
13	1072A4		PAD c/w rivets	2
STEEL CALIPERS				
1A	10578A01		CALIPER, one pair, assembly	1
1	8S03M		BOLT	1
2	8S03J		BOLT	1
3	10578A0101		SPRING, centring	4
6	59S12		NUT, nyloc	1
7	10578A0104		CAM	1
8	7S02		NUT	1
9	10578A0105		WASHER	1
10	11S02H		SCREW, set	1
11	59S12		NUT, nyloc	1
13	1072A4		PAD c/w rivets	2

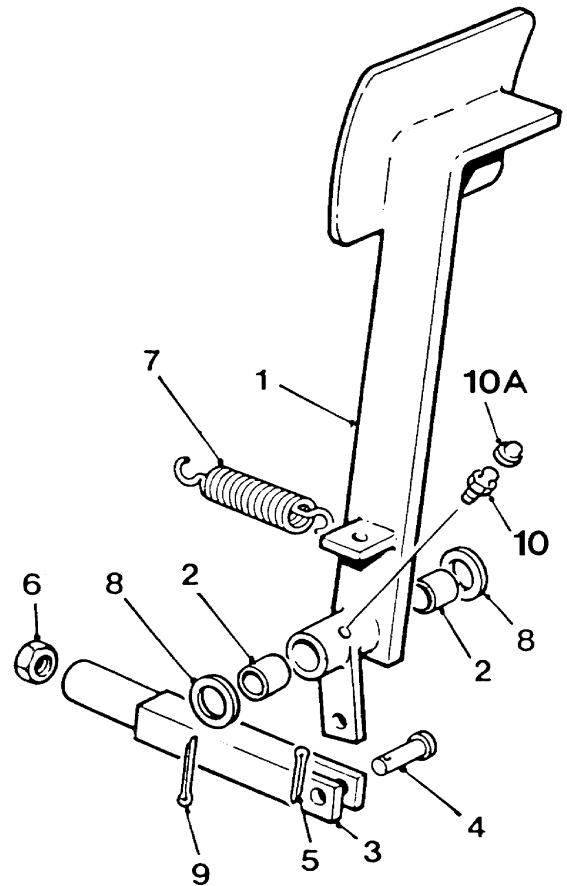
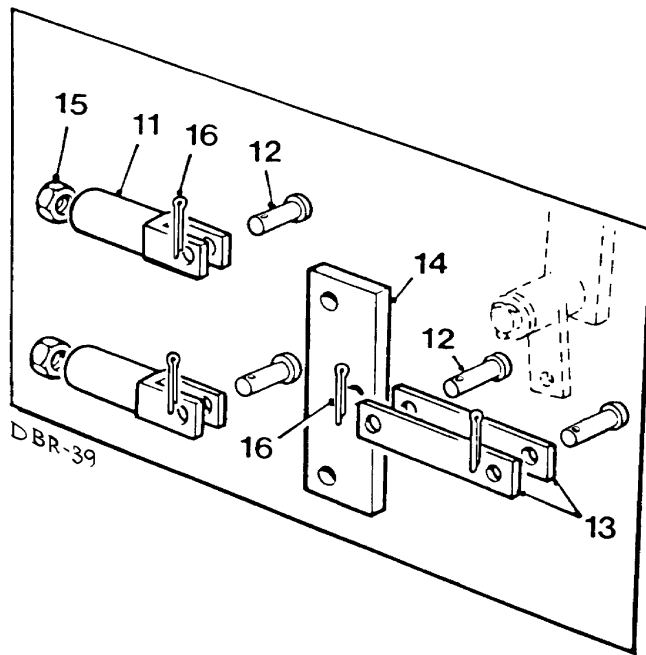

Item	Part no	Serial no	Description	Qty
Machines with single axle braking				
1	20232A01		PEDAL, brake	1
2	43S02		BUSH	2
3	10454A01	/ 0984	CLEVIS (<i>oil immersed brakes</i>)	1
3	V2004649	0985 /	CLEVIS (<i>oil immersed brakes</i>)	1
3	10454A03		CLEVIS (<i>dry disc brakes</i>)	1
4	10650A18		PIN, clevis	1
5	44S02C		PIN, split	1
6	95S03	/ 0984	NUT, 3/8"UNF (<i>oil immersed brakes</i>)	1
6	7S04	0985 /	NUT, M10 (<i>oil immersed brakes</i>)	1
6	95S02		NUT (<i>dry disc brakes</i>)	1
7	C173B		SPRING, return	1
8	10S06		WASHER, flat	2
9	44S04E		PIN, split	1
10	131S01		NIPPLE, grease	1
10A	176S01		CAP, grease nipple	1

Machines with dual axle braking

11	10454A02	/ 0984	CLEVIS	2
11	V2004650	0985 /	CLEVIS	2
12	10650A18		PIN, clevis	4
13	10436A02		LINK, pedal	2
14	20117A06		COMPENSATOR	1
15	95S03	/ 0984	NUT, 3/8"UNF	2
15	7S04	0985 /	NUT, M10	2
16	44S02C		PIN, split	4

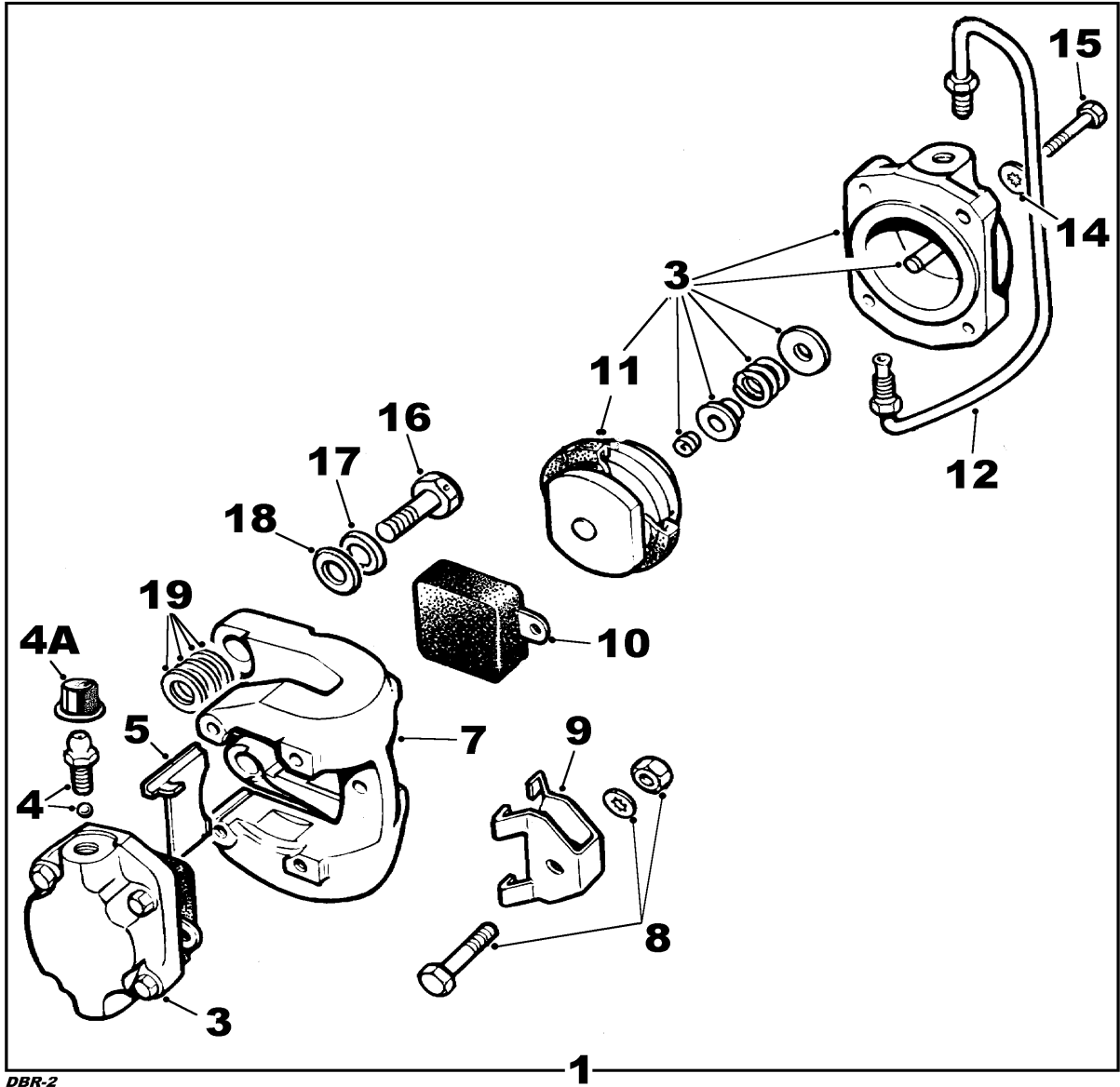

DBR-2

CALIPER, footbrake
Salisbury axle with dry disc brakes

D - 4

Item	Part no	Serial no	Description	Qty
1	20168A01		CALIPER, R.H., assembly	1
1	20168A02		CALIPER, L.H., assembly	1
3	20168A0101		PISTON & CYL. <i>(includes item 11)</i>	2
4	20168A0102		BLEED SCREW & BALL	1
4A	20168A0103		COVER, dust, bleed screw	1
5	20168A0104		PLATE support	1
7	20168A0201		BODY, caliper, L.H.	1
7	20168A0105		BODY, caliper, R.H.	1
8	20168A0106		NUT, BOLT & WASHER, keep plate	1
9	20168A0107		PLATE, keep	1
10	20168A0108		PAD, friction	set 1
11	20168A0109		KIT, seal, dust & piston	2
12	20168A0202		PIPE, bridge, L.H.	1
12	20168A0110		PIPE, bridge, R.H.	1
14	20168A0111		WASHER, shakeproof	8
15	20168A0112		BOLT	8
16	20168A0113		BOLT, caliper mounting	4
17	20168A0114		WASHER	4
18	20168A0115		WASHER	4
19	20168A0116		SHIM, 0.003"	AR
19	20168A0117		SHIM, 0.005"	AR
19	20168A0118		SHIM, 0.010"	AR
19	20168A0119		SHIM, 0.030"	AR

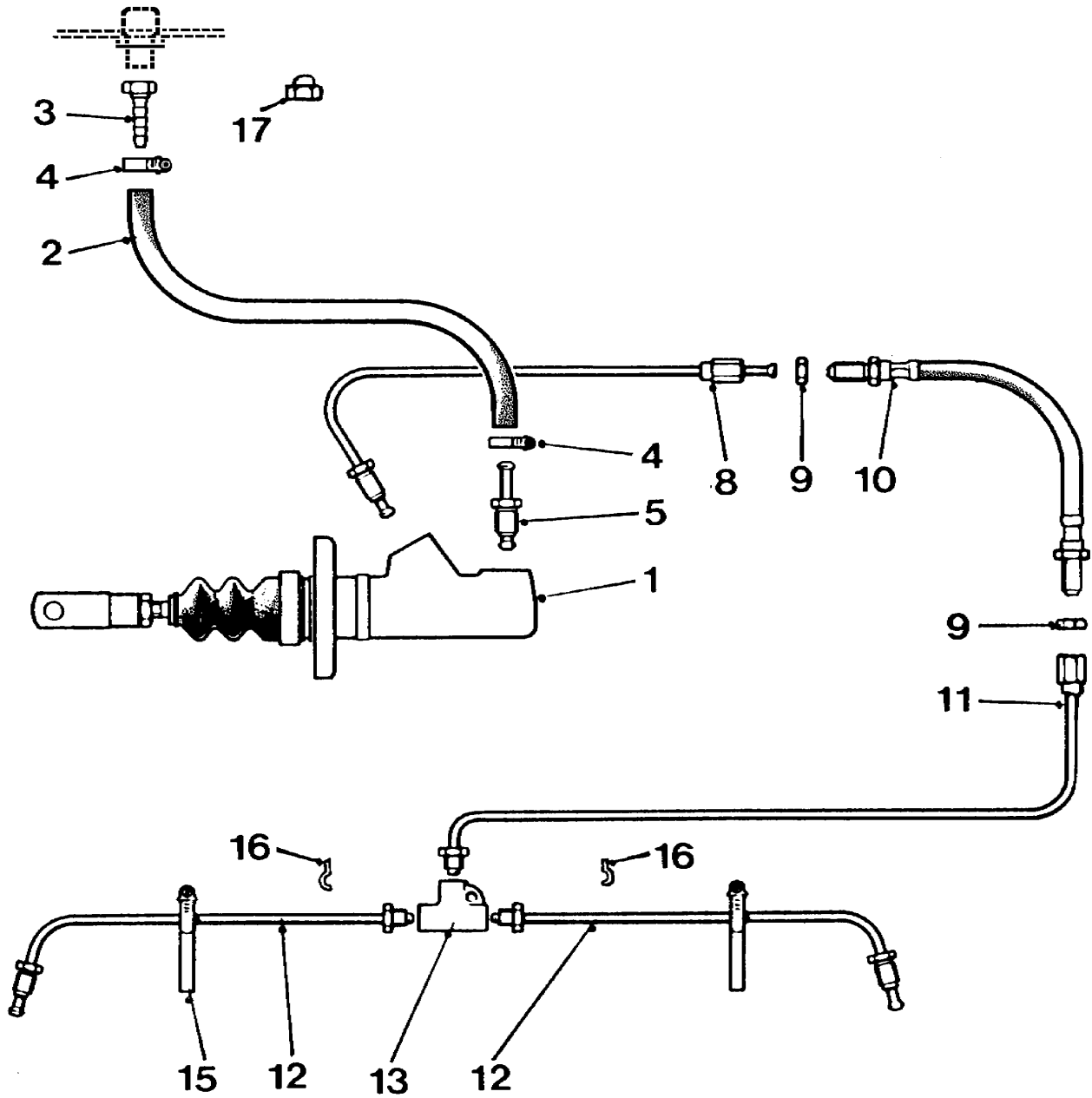

BRAKING SYSTEM, front axle braking only
Salisbury axle with OIMPD (oil immersed multi plate disc)

D - 5

Item	Part no	Serial no	Description	Qty
1		MASTER CYLINDER (<i>see page D-10</i>)	1
2	29S07		HOSE, tank to master cylinder	1
3	110S01		NOZZLE	1
4	165S04		CLIP, pipe	2
5	10542A01		PIPE, stub	1
8	10577A0101		PIPE, master cylinder to flexible pipe	1
9	10582A01		NUT	1
10	10517A02		HOSE	1
11	10577A0110		PIPE, flexible pipe to tee	1
12	10577A0206		PIPE, tee to wheel cylinder	2
13	152S03		FITTING, adaptor, 3 way	1
15	97S15		CLIP, jubilee	2
16	4S133		CLIP, pipe	2
17	120S01A		CAP, blanking	1

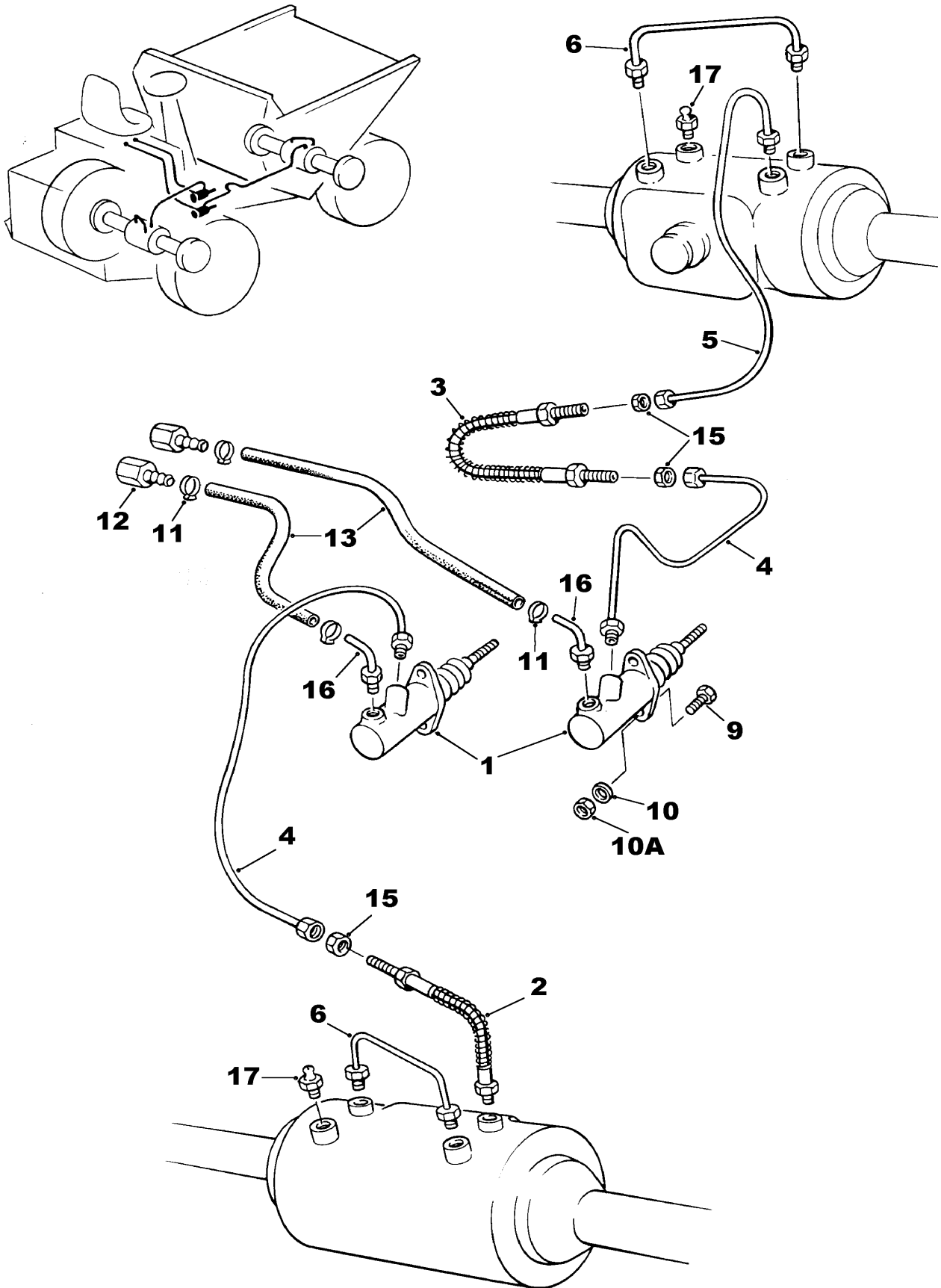

BRAKING SYSTEM, (Up to serial number 1092)**D - 6****Newage axles, front & rear braking**

Item	Part no	Serial no	Description	Qty
1		MASTER CYLINDER (see page D-10)	2
2	10516A02	/ 1092	BRAKE HOSE, rear	1
3	10517A02	/ 1092	BRAKE HOSE, front	1
4	V2000302	/ 1092	PIPE, master cylinders to brake hoses	2
5	10577A0102	/ 1092	PIPE, front brake hose to front axle	1
6	10577A0213	/ 1092	PIPE, axle bridge	2
9	8S03C		BOLT	4
10	267S05		WASHER, flat	4
10A	59S12		NUT	4
11	165S04		CLIP, hose	4
12	110S01A		NOZZLE	2
13	29S07		HOSE, master cylinders to tank	2
15	10582A01	/ 1092	NUT, locking	3
16	10542A01	/ 1092	PIPE, stub	2
17	182S20		SCREW, bleed	2

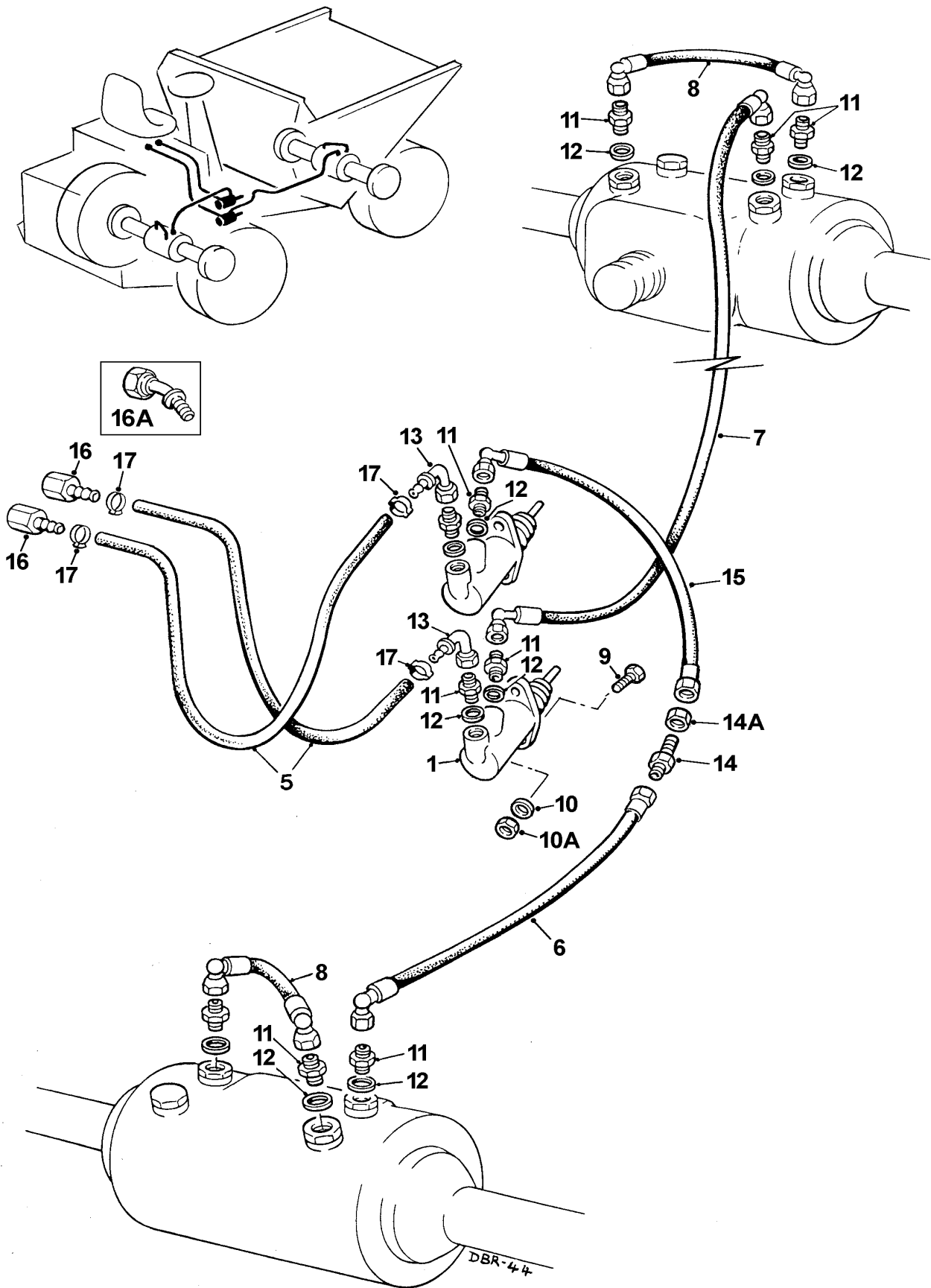

BRAKING SYSTEM, (From serial number 1093)**D - 6A****Newage axles, front & rear braking**

Item	Part no	Serial no	Description	Qty
1		MASTER CYLINDER (<i>see page D-10</i>)	2
5	29S07		HOSE, nylon, one metre long	2
6	318S01L	1093 /	HOSE, axle beam to bulkhead fitting	1
7	320S01E	1093 /	HOSE, m/cyl to front axle (HT/HD/RS)	1
7	320S01D	1093 /	HOSE, m/cyl to front axle (HRS skip)	1
8	53S01W	1093 /	HOSE, axle bridge	2
9	8S03C		BOLT	4
10	267S05		WASHER, flat	4
10A	59S12		NUT, self locking, 'Nyloc'	4
11	V2003515	1093 /	ADAPTOR, male/male, straight	10
12	298S03	1093 /	SEAL, bonded	10
13	129S01A	1093 /	ADAPTOR, elbow, 90 deg.	2
14	93S03	1093 /	ADAPTOR, bulkhead c/w nut	1
15	32S01C	1093 /	HOSE, master cyl. to bulkhead fitting	1
16	110S01A		ADAPTOR, nozzle	2
16A	135S01		ADAPTOR, nozzle, swept 135 deg. (<i>Used with hydraulic rotating skips</i>)	
17	165S04		CLIP, hose	2
.....	182S20		BLEED SCREW, supplied with axle (<i>not illustrated</i>)	

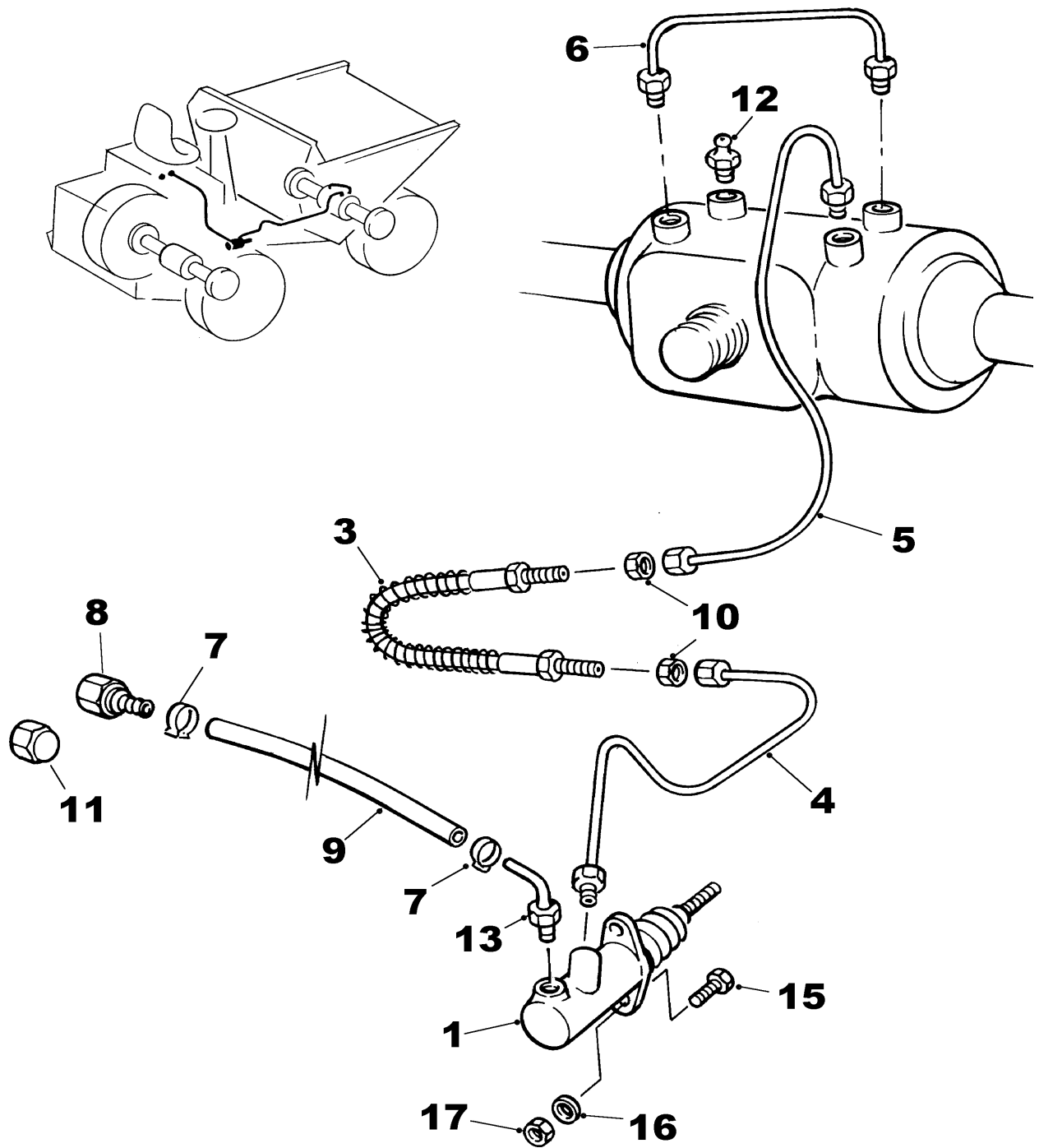

BRAKING SYSTEM, (Up to serial number 1092)**D - 7****Newage front axle braking only**

Item	Part no	Serial no	Description	Qty
1		MASTER CYLINDER <i>(see page D-10)</i>	1
3	10517A02	/ 1092	BRAKE HOSE	1
4	V200302	/ 1092	PIPE, m/cyl. to brake hose	1
5	10577A0102	/ 1092	PIPE, brake hose to front axle	1
6	10577A0213	/ 1092	PIPE, axle bridge	1
7	165S04		CLIP, hose	2
8	110S01A		NOZZLE	1
9	29S07		HOSE, m/cyl. to tank	1
10	10582A01	/ 1092	NUT, locking	2
11	120S01		CAP, blanking, tank	1
12	182S20		SCREW, bleed	1
13	10542A01	/ 1092	PIPE, stub	1
15	8S03C		BOLT	2
16	267S05		WASHER, flat	2
17	59S12		NUT, self-locking	2

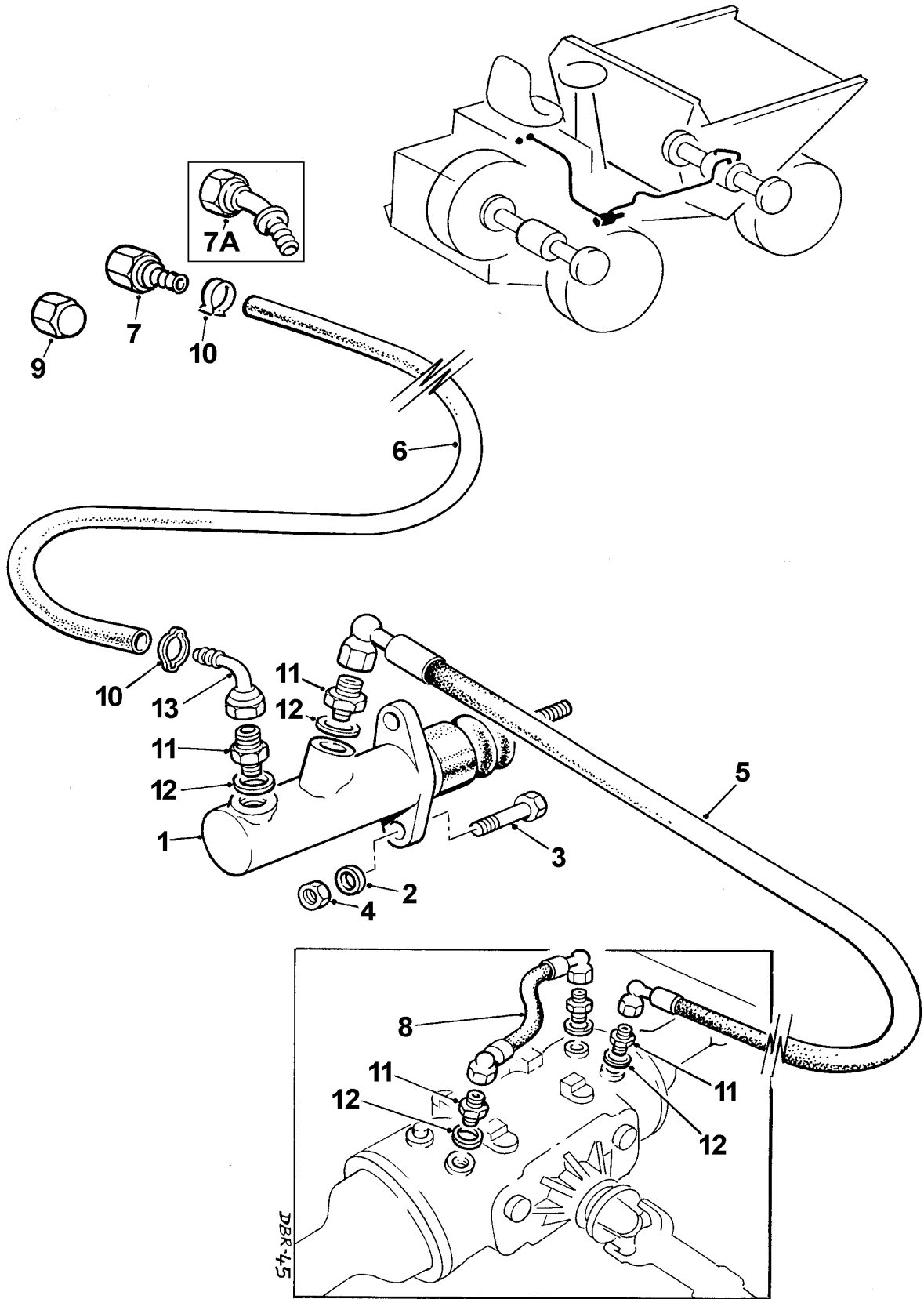

BRAKING SYSTEM, (From serial number 1093)**D - 7A****Newage front axle braking only**

Item	Part no	Serial no	Description	Qty
1		MASTER CYLINDER <i>(see page D-10)</i>	1
2	267S05		WASHER, flat	2
3	8S03C		BOLT	2
4	59S12		NUT, self-locking, 'Nyloc'	2
5	320S01E	1093 /	HOSE, master cylinder to front axle	1
6	29S07		HOSE, nylon, one metre long	1
7	110S01A		ADAPTOR, nozzle, straight	1
7A	135S01		ADAPTOR, nozzle, swept 135 deg. <i>(Used with hydraulic rotating skips)</i>	1
8	53S01W	1093 /	HOSE, axle bridge	1
9	120S01		CAP, blanking	1
10	165S04		CLIP, nylon hose	2
11	V2003515	1093 /	ADAPTOR, male/male	5
12	298S03	1093 /	SEAL, bonded	5
13	129S01A	1093 /	ADAPTOR, elbow	1
.....	182S20		BLEED SCREW, supplied with axle <i>(not illustrated)</i>	1

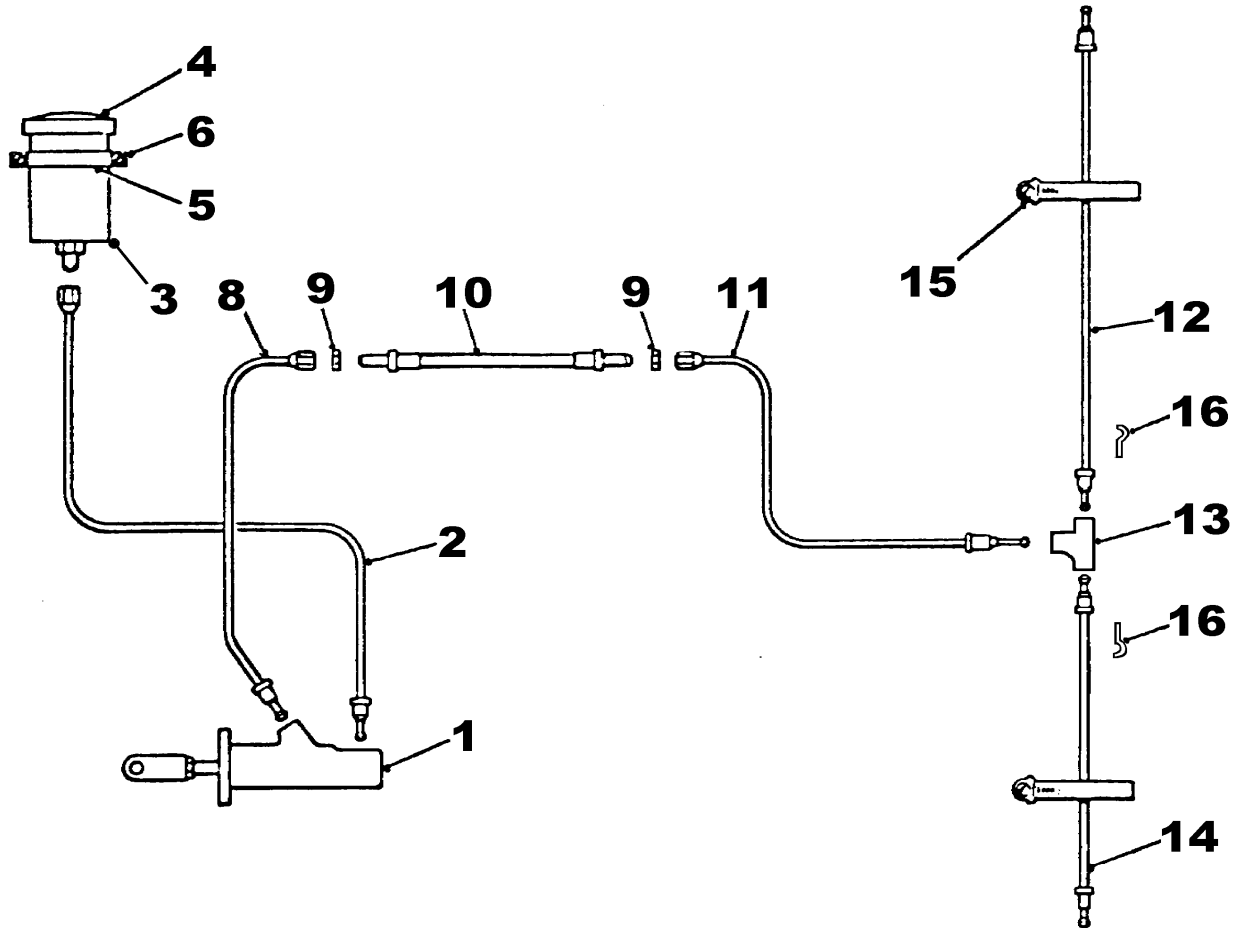

BRAKING SYSTEM**D - 8****Salisbury front axle with dry disc brakes**

Item	Part no	Serial no	Description	Qty
1	20102A03		MASTER CYLINDER <i>(see page D-9)</i>	1
2	DM89-2		PIPE, resevoir to master cylinder	1
3	10659A01		RESERVOIR	1
4	10659A0101		CAP, reservoir	1
5	10659A0102		CLIP, reservoir	1
6	82S03G		SCREW	2
6	85S01		NUT, nylon insert	2
8	DM79-3		PIPE, master cylinder to flexible hose	1
9	95S03		NUT, locking	2
10	10658A01		HOSE, flexible	1
11	DM79-1		PIPE, flexible hose to tee	1
12	DM78-1		HOSE, tee to L.H. brake caliper	1
13	152S04		FITTING, tee	1
14	DM78-2		HOSE, tee to R.H. brake caliper	1
15	97S15		CLAMP, pipe	2
16	4S133		CLIP, pipe	2

The following item is not illustrated

-	120S01A		CAP, blanking, hydraulic tank	2
---	---------	--	-------------------------------	---

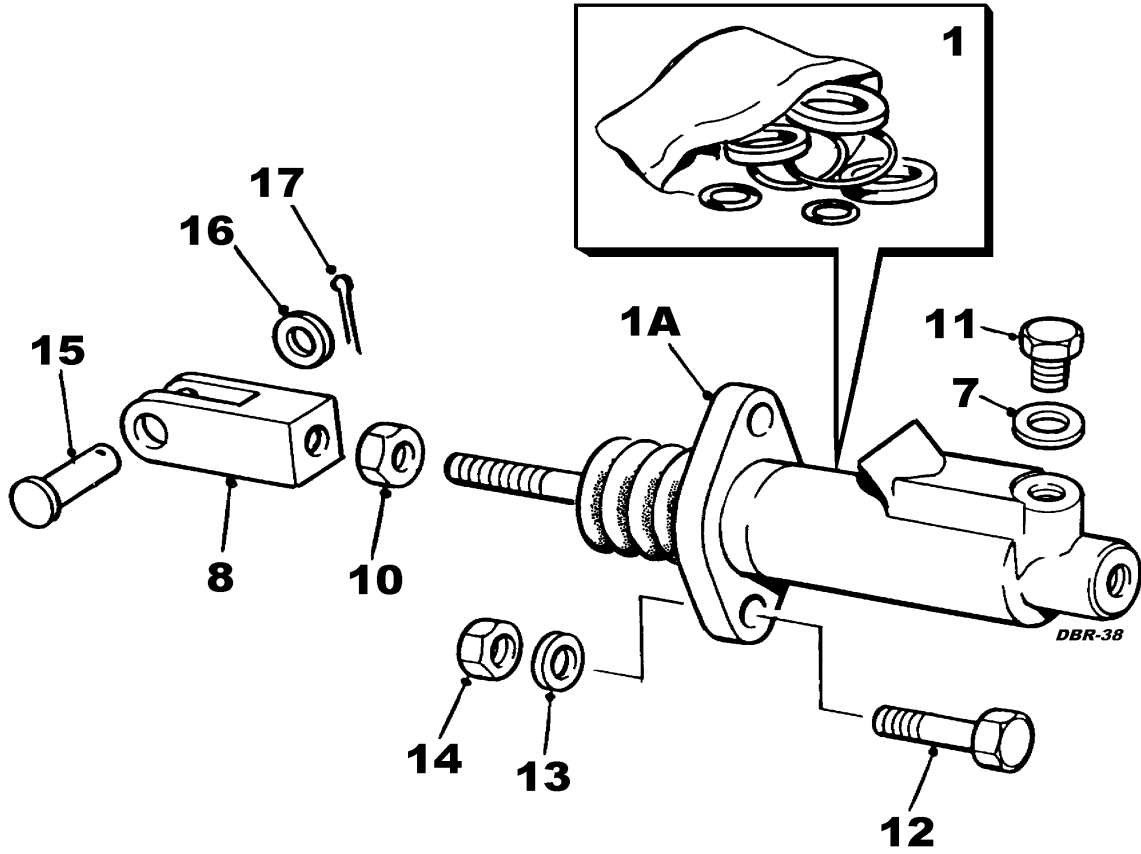

MASTER CYLINDER**D - 9****Salisbury front axle with dry disc brakes**

Item	Part no	Serial no	Description	Qty
1A	20102A03		MASTER CYLINDER, assembly	1
1	20102A0301		KIT, seals, clips & gaiter	1
7	20102A0307		WASHER	1
8	20102A0308		CLEVIS	1
10	20102A0310		NUT, locking	1
11	20102A0311		PLUG	1
12	8S03C		BOLT	2
13	267S05		WASHER, flat	2
14	59S12		NUT, self-locking	2
15	C174Y		PIN, clevis	1
16	10S02		WASHER	1
17	44S02C		PIN, split	1

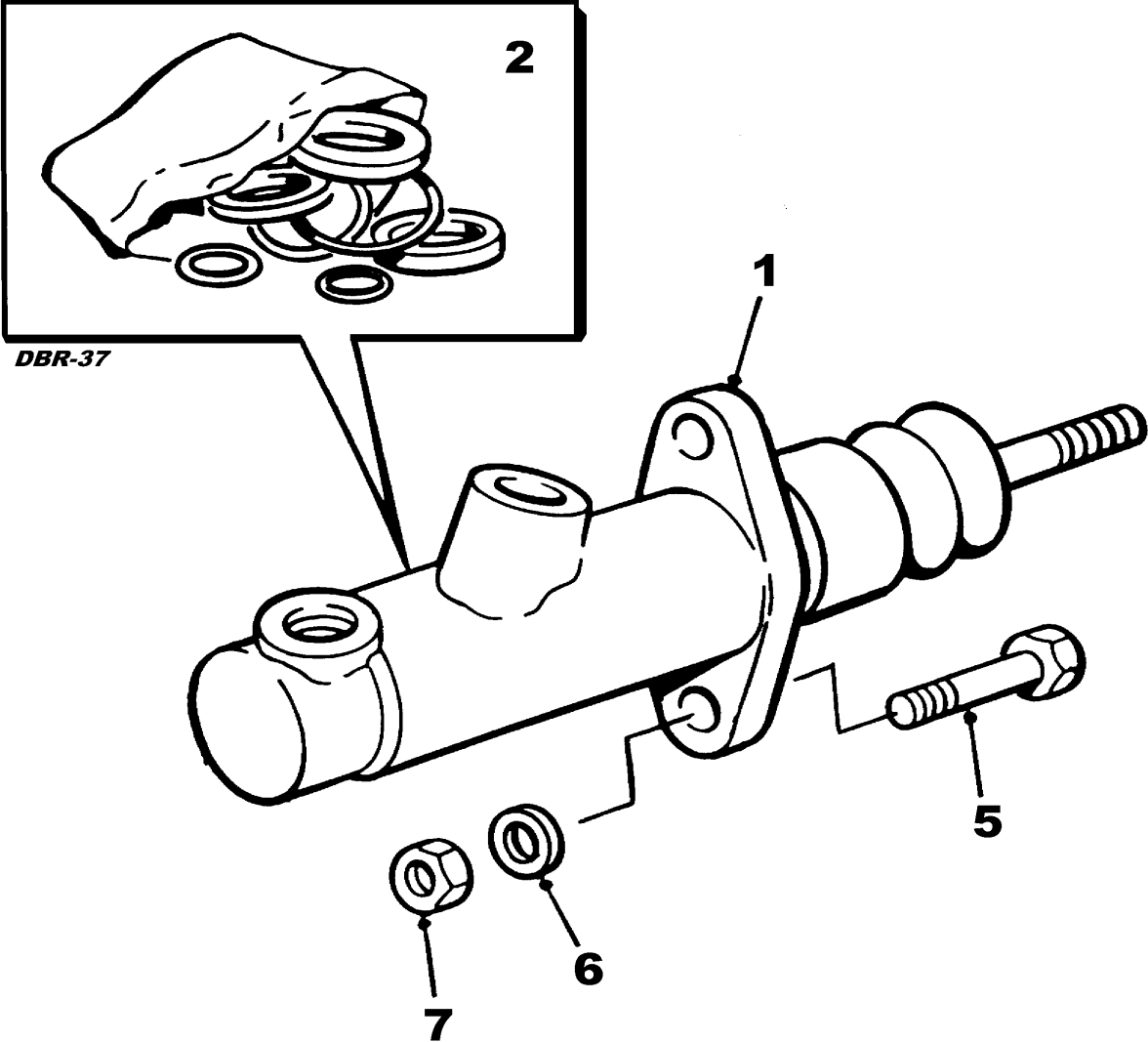

Item	Part no	Serial no	Description	Qty
------	---------	-----------	-------------	-----

*Dumpers are fitted with either GIRLING or FRENOS IRUNA Master Cylinders.
Be sure to quote the name marked on the Master Cylinder before ordering parts.*

GIRLING

1	20102A02		MASTER CYL. with 3/8" UNF rod	1
1	V2004651		MASTER CYL. with M10 rod	1

FRENOS IRUNA

1	V2003671		MASTER CYL. with 3/8" UNF rod	1
2	10570A01		REPAIR KIT, m/cyl. GIRLING	
2	V601697		REPAIR KIT, m/cyl. FRENOS IRUNA	

5	8S03C		BOLT	2
6	267S05		WASHER, flat	2
7	59S12		NUT, self-locking	2

Engines

FUEL TANK and hoses

Petter PH2 & P600/2 and Lister ST engines **E - 1**

FUEL TANK and hoses

Lister TS2 & TR2 engines **E - 1A**

AIR CLEANER

Petter PH2 & Lister ST engines **E - 2**

AIR CLEANER

Lister TS2 & TR2 engines **E - 2A**

SILENCERS

Silencer, *Not* R.O.P.S. **E - 3**

Silencer, R.O.P.S. **E - 3A**

ENGINE STOP PULL

Petter PH2 & P600/2 and Lister ST **E - 4**

Lister TS2 & TR2 engines **E - 4**

ACCELERATOR **E - 5**

ENGINES **E - 6**

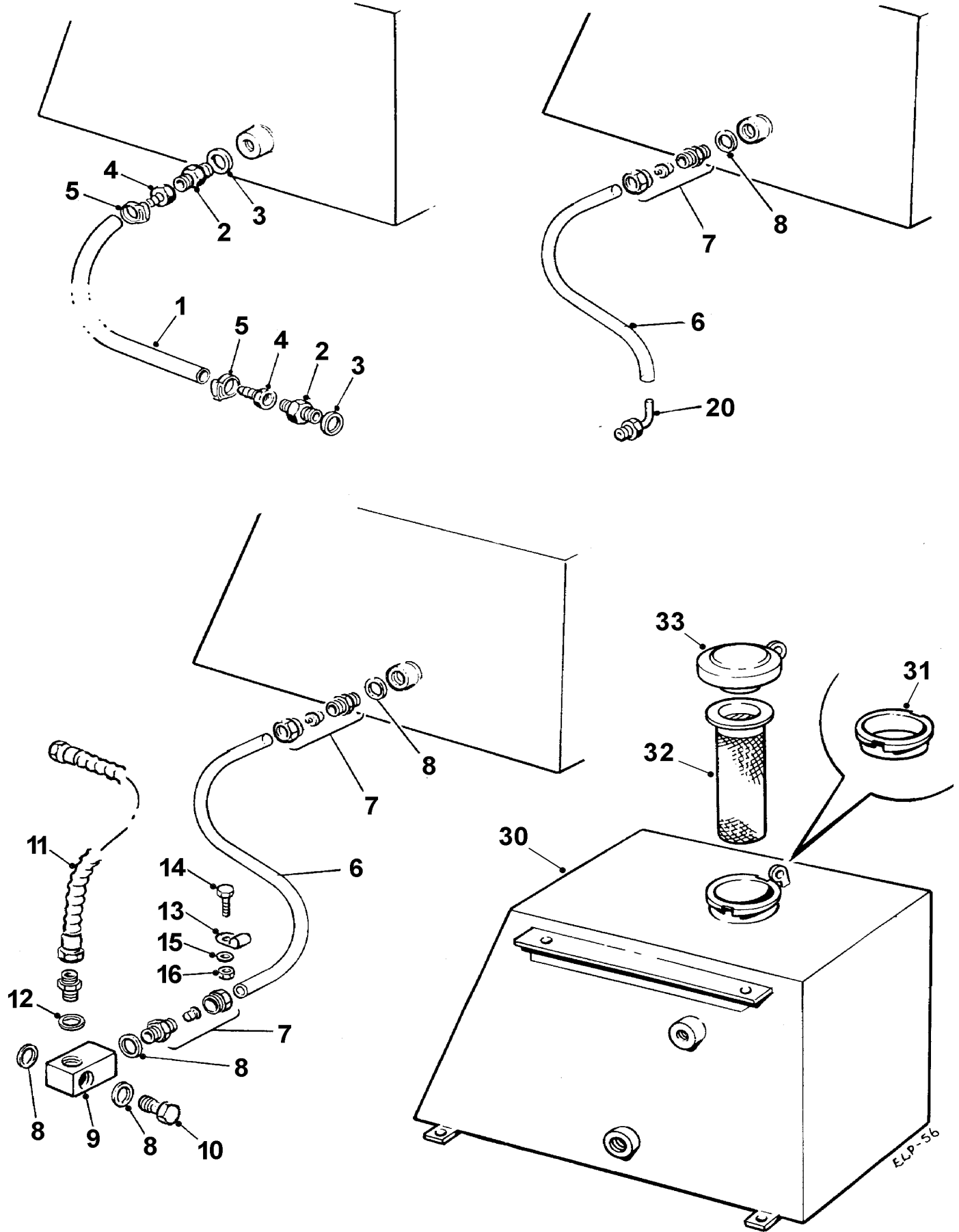

FUEL TANK & PIPES**E - 1****Petter PH2 & P600/2, and Lister ST engines**

Item	Part no	Serial no	Description	Qty
1	29S15		HOSE (order by metre)	AR
2	122S02		FITTING, adaptor	2
3	435364		WASHER	1
4	110S01A		NOZZLE, push on	2
5	165S04		CLIP, hose	2
6	29S16		HOSE (order by metre)	AR
7	10315A01		COUPLING	2
8	116S08		WASHER, copper	4
9	10775A01		BLOCK, adaptor	1
10	115S03B		BOLT, banjo	1
11	10357A04		HOSE, leak back	1
12	116S01		WASHER, copper	1
13	10350A01		CLIP, hose	2
14	11S02C		SCREW, set	2
15	17S03		WASHER, spring	2
16	7S02		NUT	2
20	51435		FITTING, elbow	1
Petter P600/2				
30	40281A15		TANK, fuel	1
31	10561A02		COLLAR, filler (<i>welded to tank</i>)	1
Lister ST2, Petter PH2				
30	40281A04		TANK, fuel	1
31	10561A02		COLLAR, filler (<i>welded to tank</i>)	1
32	10379A03		FILTER STRAINER	1
33	10378A03		CAP, tank	1

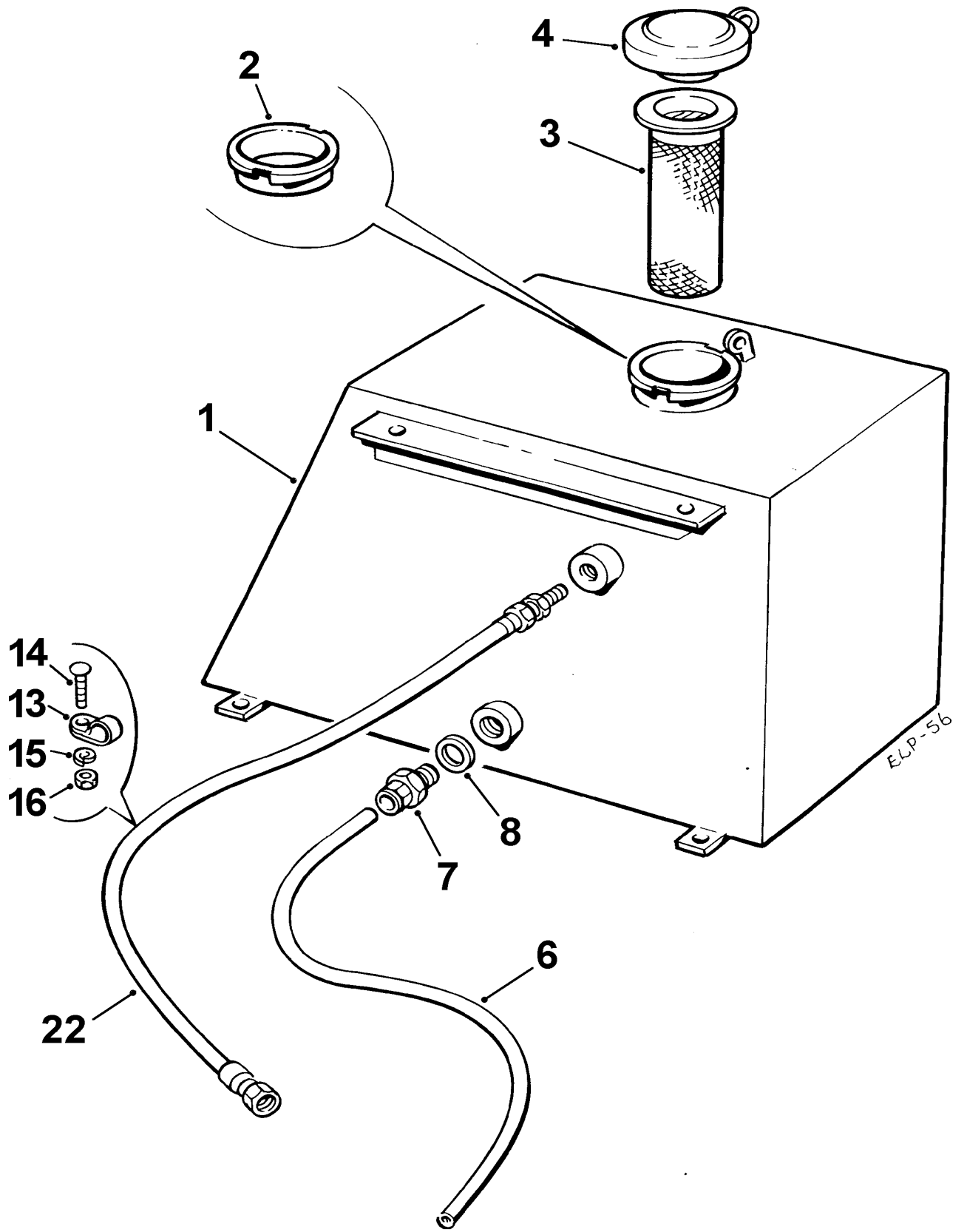

FUEL TANK & PIPES
Lister TS2 & TR2 engines

E - 1A

Item	Part no	Serial no	Description	Qty
1	40281A15		TANK, fuel	1
2	10561A02		COLLAR, filler (<i>welded to tank</i>)	1
3	10379A03		FILTER STRAINER	1
4	10378A03		CAP, tank	1
6	29S05A		HOSE	1
7	10315A01		FITTING coupling	1
8	116S08		WASHER, copper	1
13	143200900		CLIP, hose	2
14	200S09C		SCREW, round head	2
15	17S02		WASHER, spring	2
16	104S15		NUT	2
22	10357A05		HOSE, leak off	1

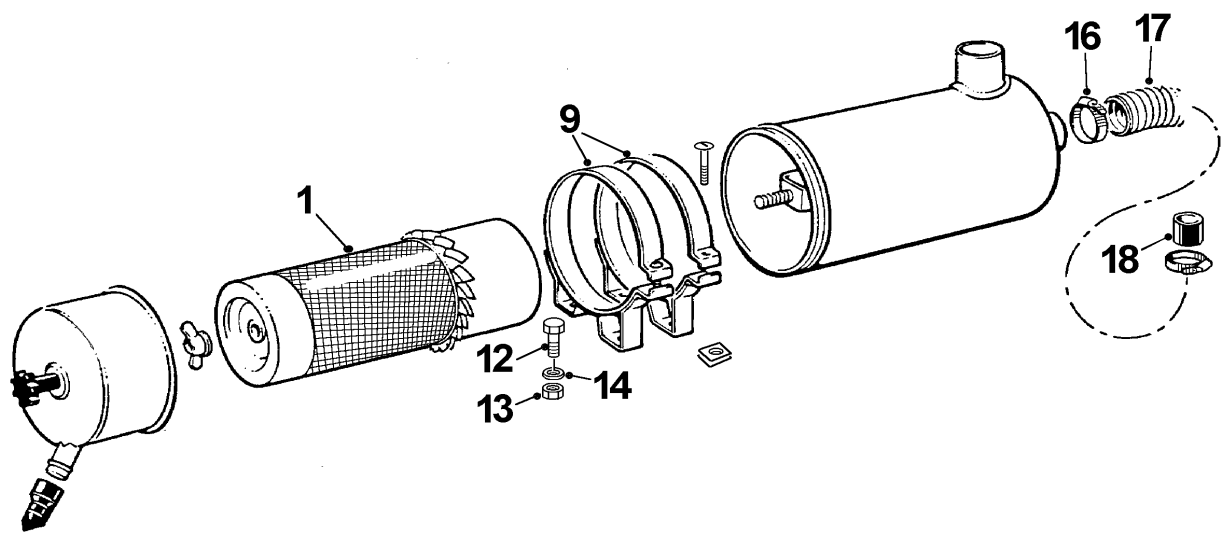
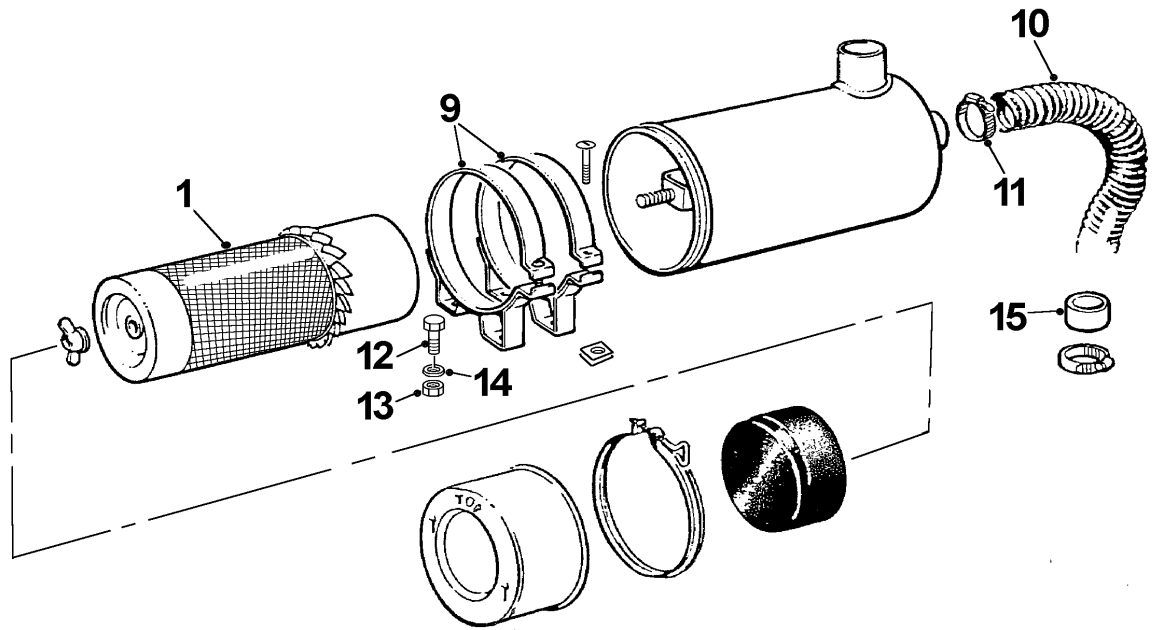

Item	Part no	Serial no	Description	Qty
Note: Air cleaner for Petter P600/2 is not illustrated. Consult "Engine Parts Manual".				
-	10532A01		AIR CLEANER, assembly	1
1	10532A0101		ELEMENT	1
9	10533A01		CLAMP, band	2
10	10840A03		HOSE	1
11	97S12		CLIP, hose	2
12	8S03A		BOLT	4
13	61S03		NUT	4
14	12S03		WASHER, flat	4
15	10320A06		ADAPTOR, sleeve	1
16	97S11		CLIP	1
17	10840A07		HOSE (order by metre)	AR
18	10320A01		ADAPTOR, sleeve	1

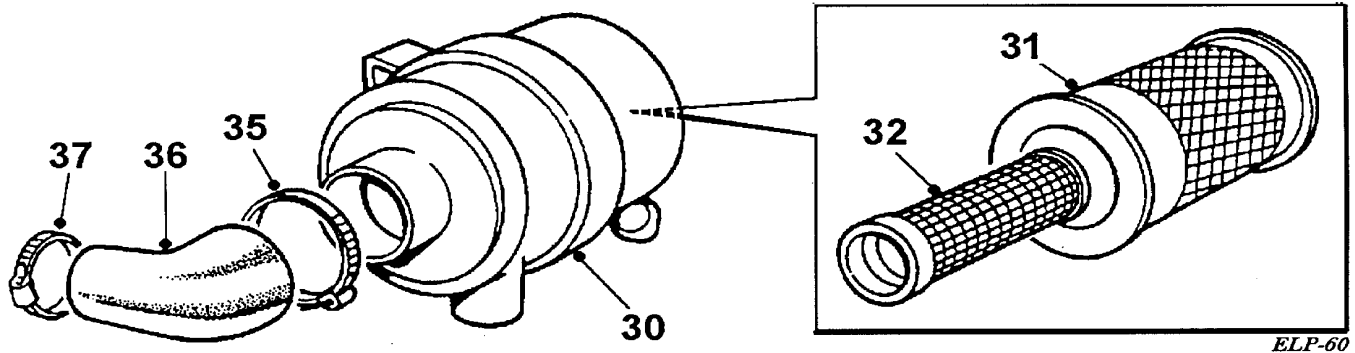
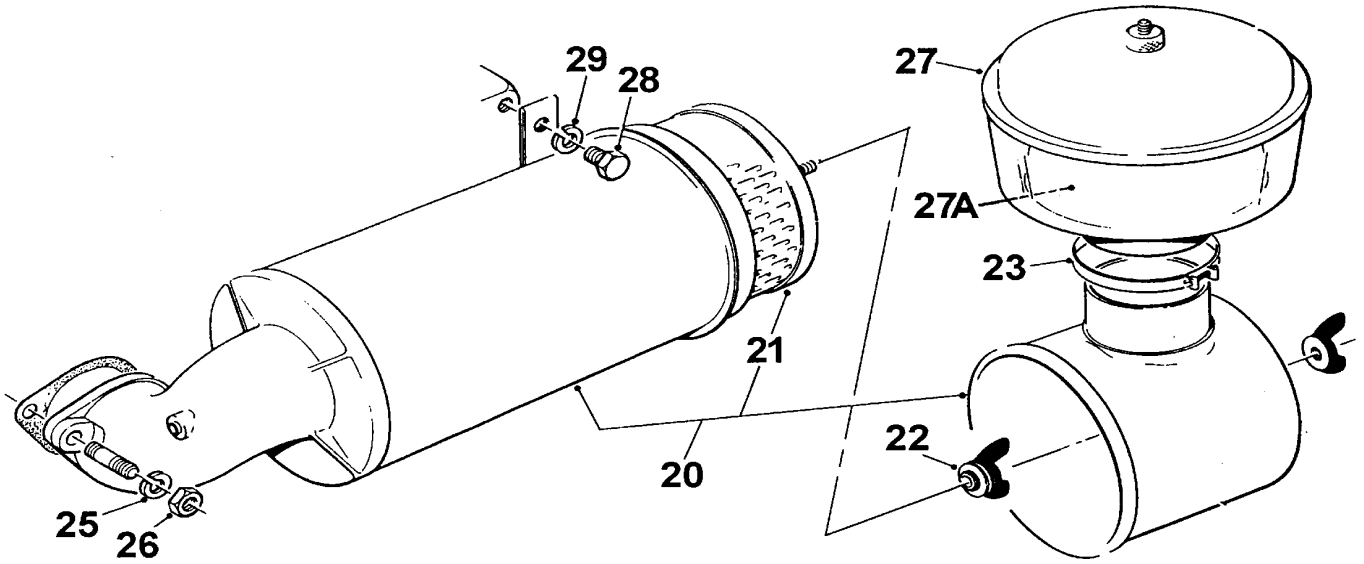

AIR CLEANER, Lister TS2 & TR2 engines

E - 2A

Item	Part no	Serial no	Description	Qty
20		AIR CLEANER, (metal casing) assembly OBSOLETE: Order kit EL57041611	1
21	EL20233380		ELEMENT	1
22	V600487		WING NUT & SEAL	1
23	97S13		CLIP	1
25	17S04		WASHER, spring	2
26	7S03		NUT	2
27	V602685		PRE-CLEANER, assembly	1
27A	V602269		BOWL, dust collector	1
28	11S03A		SCREW, set	1
29	17S04		WASHER, spring	1
30	V2004182		AIR CLEANER, (plastic casing) assembly	1
31	V2004185		ELEMENT, main	1
32	V2004186		ELEMENT, safety	1
35	97S17		CLIP, hose	1
36	V2004183		ELBOW, rubber	1
37	97S13		CLIP, hose	1

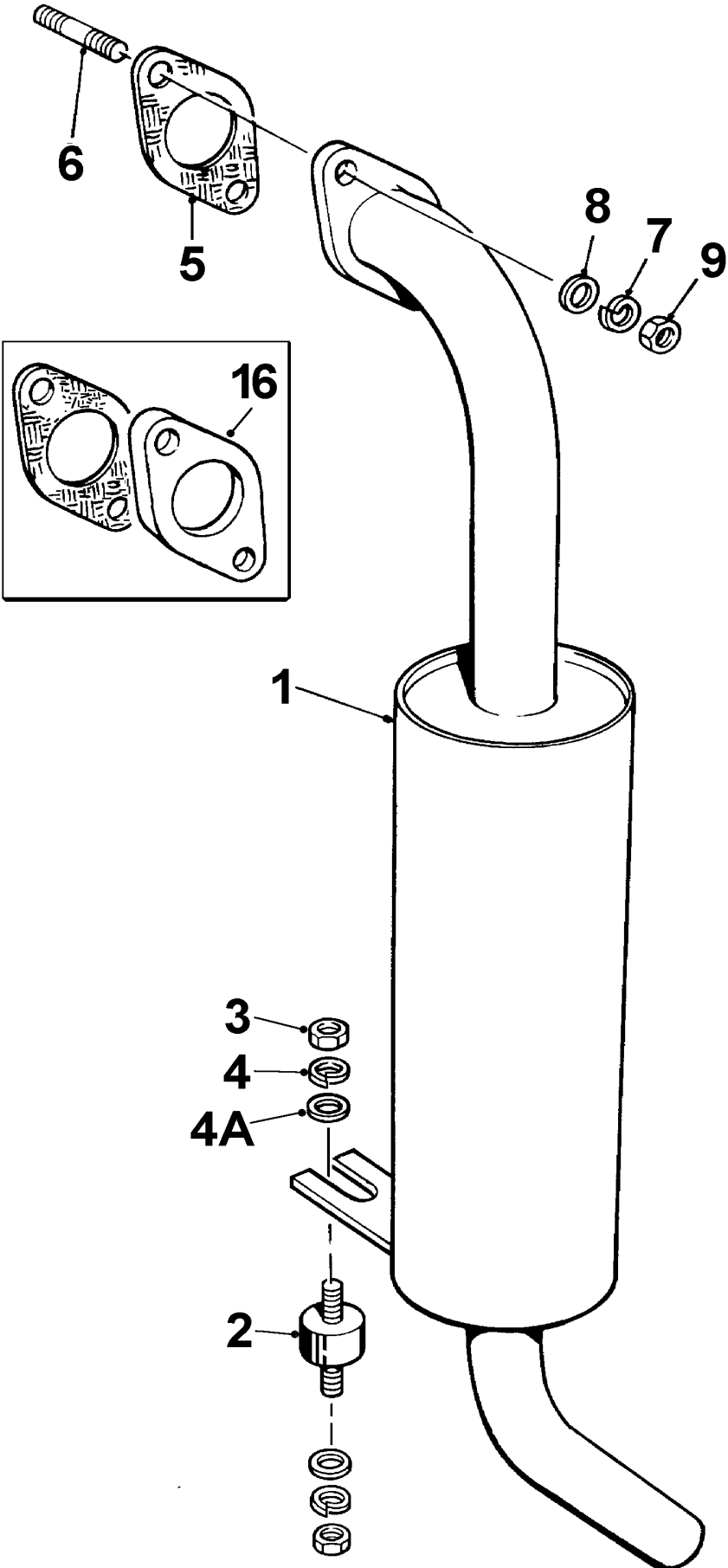

SILENCER (not used with R.O.P.S. frame)**E - 3**

Item	Part no	Serial no	Description	Qty
1	30154A18		SILENCER, Petter P600/2	1
1	30154A09		SILENCER, Petter PH2	1
1	30154A13		SILENCER, Lister ST2	1
1	30154A17		SILENCER, Lister TS2 & TR2	1
.....	30154A15		SILENCER, Hatz (not illustrated)	1
2	10371A01		MOUNTING, rubber	1
3	7S03		NUT	2
4	17S04		WASHER, spring	2
4A	267S05		WASHER, flat	2
5	10293A02		GASKET, silencer, Petter PH2	2
5	10293A03		GASKET, silencer, Lister	2
			Petter P600/2, Lister TS2 & TR2	
6	11S04C		BOLT, M10 x 25, OBSOLETE: use stud	
6	411411035		STUD, M10 X 35	2
7	17S05		WASHER, spring	2
8	267S06		WASHER, flat	2
9	7S04		NUT	2
			Petter PH2	
6	213S02E		BOLT, 5/16" BSF x 1"	2
7	41S04		WASHER, spring	2
			Lister ST2	
6	6S02D		BOLT, 5/16" UNF X 1 5/8"	2
7	41S05		WASHER, spring	2
16	10446A01		FLANGE, spacer, Lister ST2	1

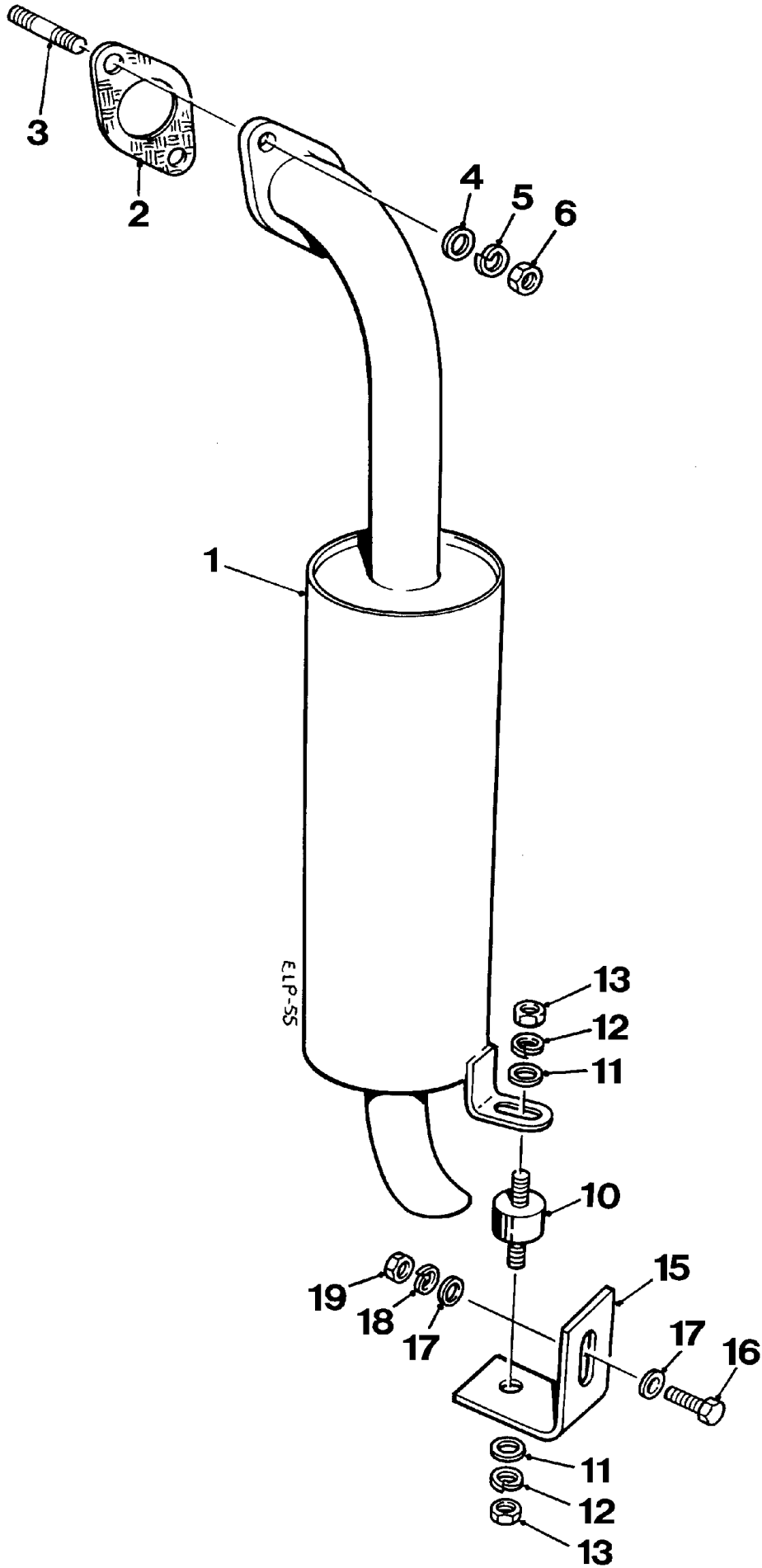

SILENCER, TS/TR2 engines (used with ROPS frame)**E - 3A**

Item	Part no	Serial no	Description	Qty
....	V602755	May-99 /	KIT, silencer <i>(consists of all items below)</i>	1
1	30154A21		SILENCER	1
2	10293A03		GASKET	1
3	411411035		STUD	2
4	267S06		WASHER, flat	2
5	17S05		WASHER, spring	2
6	7S04		NUT	2
10	10371A01		MOUNT, rubber	1
11	267S05		WASHER, flat	2
12	17S04		WASHER, spring	2
13	7S03		NUT	2
15	V2005033		BRACKET	
16	11S04E		SCREW, set	1
17	267S06		WASHER, flat	2
18	17S05		WASHER, spring	1
19	7S04		NUT	1

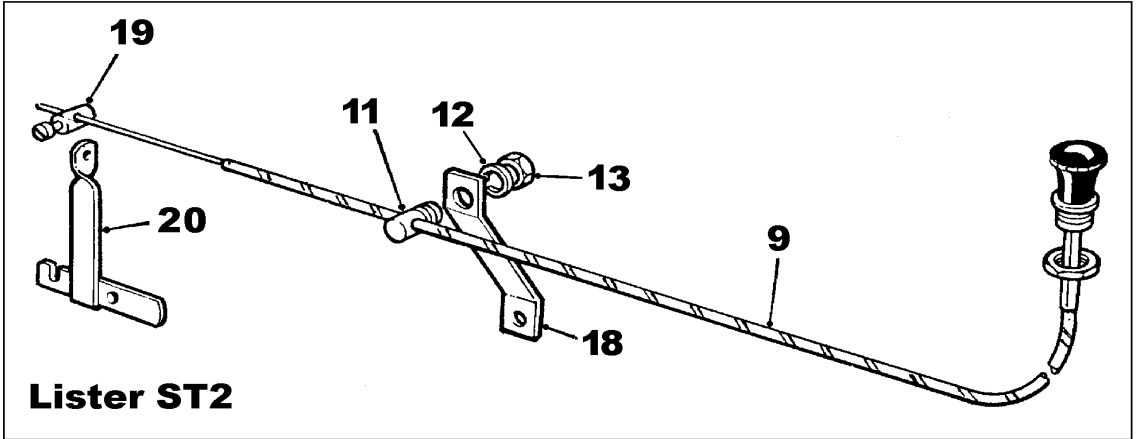
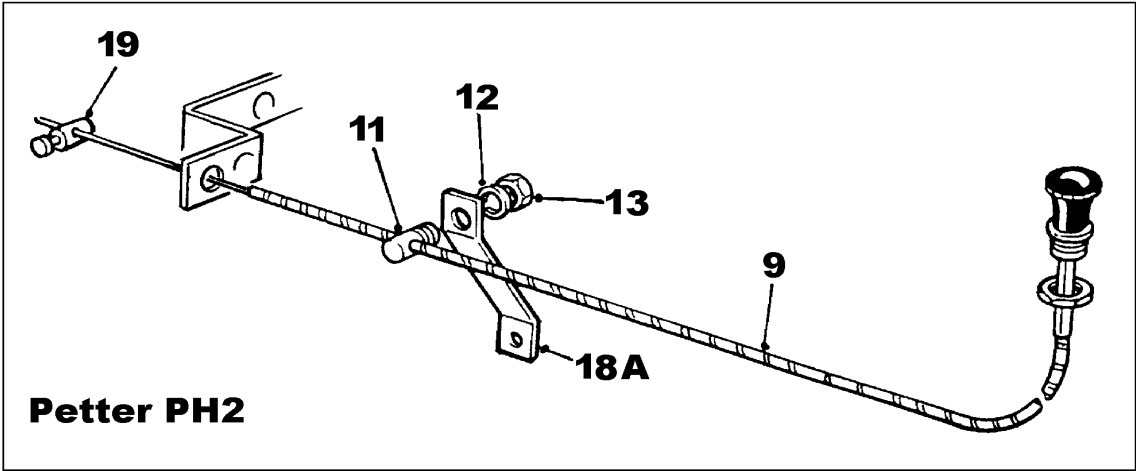
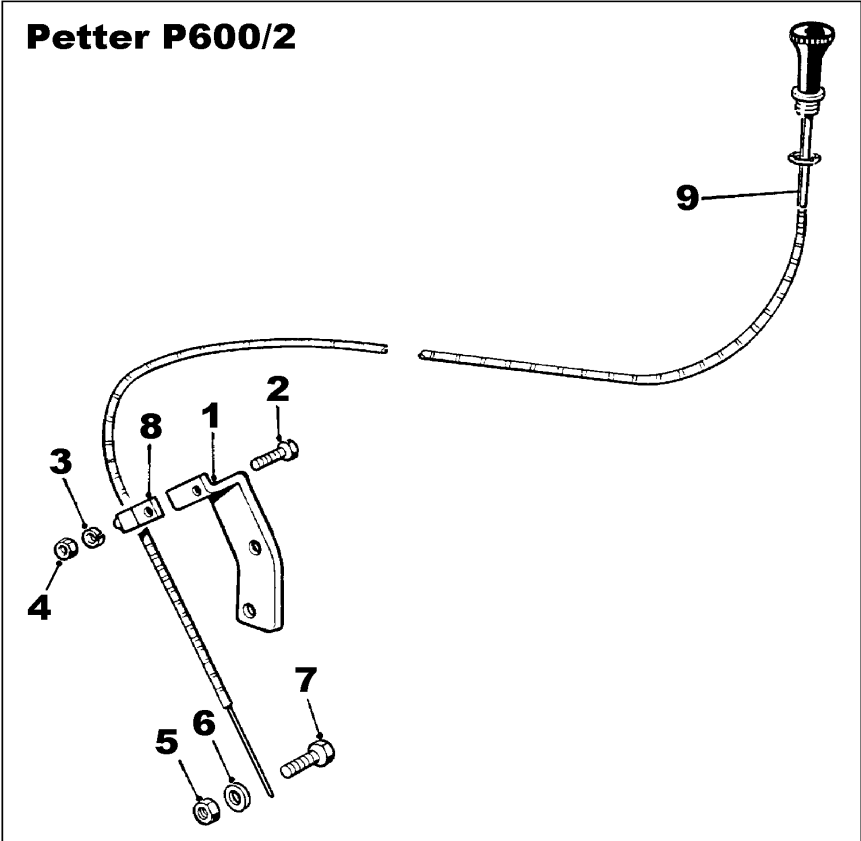

ENGINE STOP CONTROL
Petter P6002, Petter PH2, Lister ST2

E - 4

Item	Part no	Serial no	Description	Qty
1	11029A02		BRACKET, Petter P600/2	1
2	11S01AA		SCREW, set	1
3	17S02		WASHER, spring	1
4	7S01		NUT	1
5	59S14		NUT, self-locking	1
6	267S04		WASHER, flat	1
7	11033A01		SCREW	1
8	V600191		CLIP, stop cable	1
9	460239		CABLE, engine stop	1
11	460242		CLAMP, screw	1
12	67S04		WASHER, shakeproof	1
13	87S03		NUT, "Binx"	1
18	10209A03		BRACKET, Lister ST2	1
18A	10209A04		BRACKET, Petter PH2	1
19	435196		NIPPLE	1
20	10346A01		LEVER, Lister ST2	1

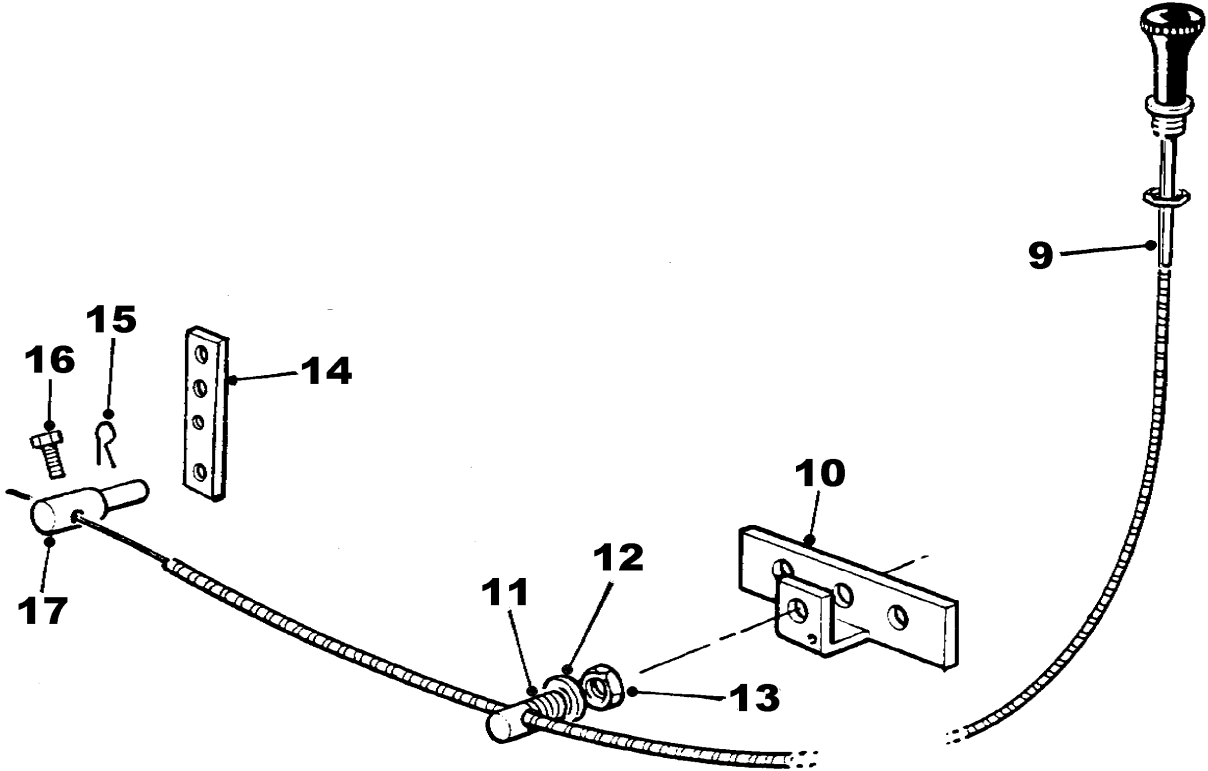

ENGINE STOP CONTROL
Lister TS2 & TR2

E - 4

Item	Part no	Serial no	Description	Qty
9	460239		CABLE, engine stop	1
10	11029A01		BRACKET, Lister TS2 & TR2	1
11	460242		CLAMP, screw	1
12	67S04		WASHER, shakeproof	1
13	87S03		NUT, "Binx"	1
14	11030A01		LEVER, pivot, Lister TS2 & TR2	1
15	V600193		CLIP	1
16	V600192		SCREW	1
17	V600194		SWIVEL	1

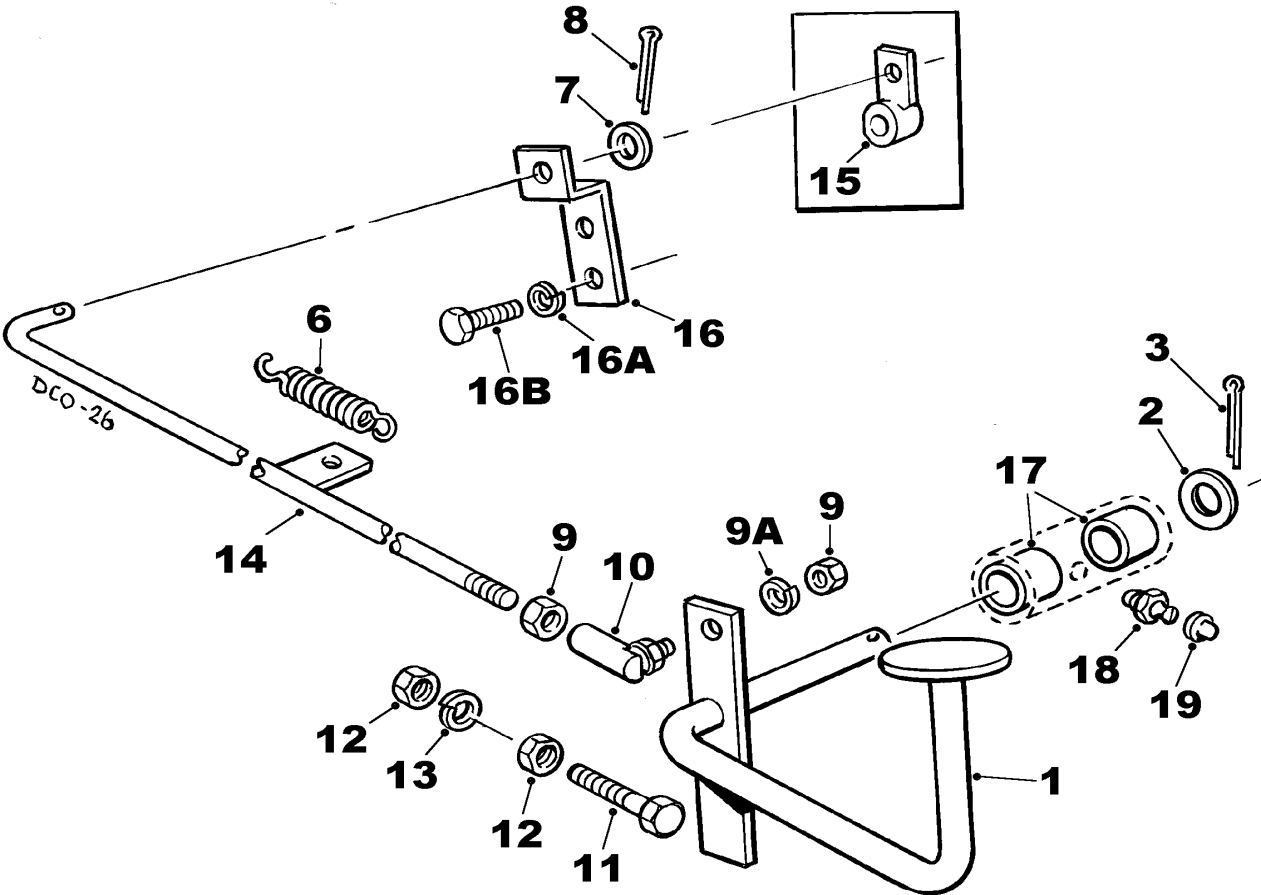
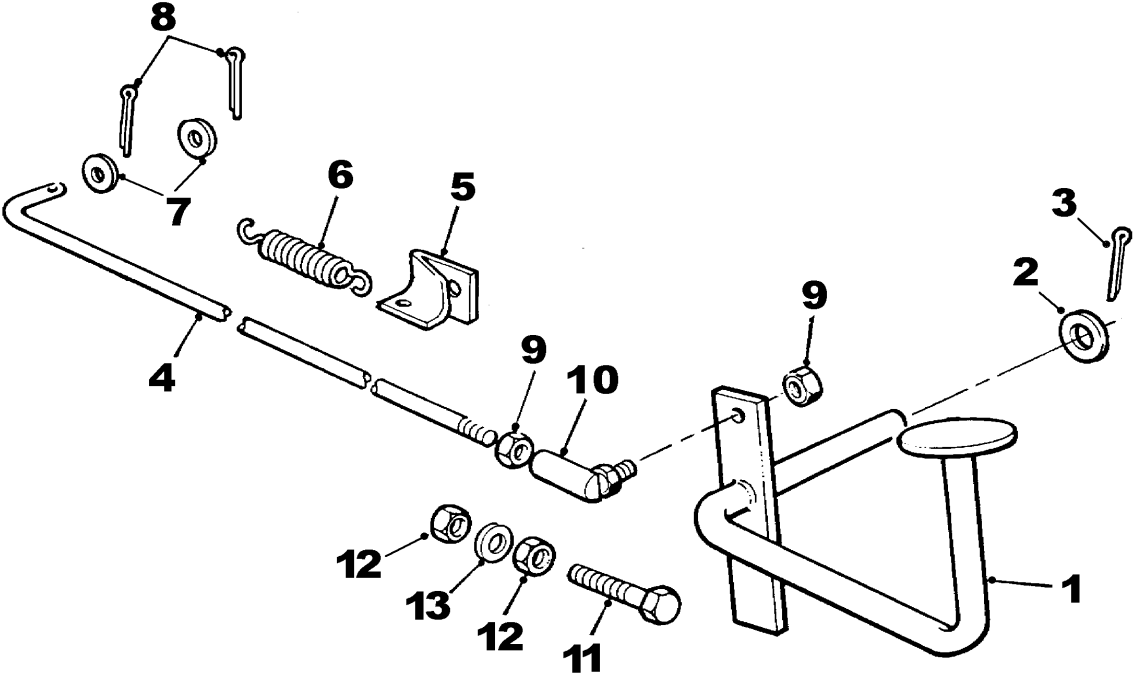

ACCELERATOR**E - 5**

Item	Part no	Serial no	Description	Qty
1	20231A02		PEDAL, accelerator	1
2	10S04		WASHER, flat	1
3	44S02C		PIN, split	1
4	20166A02		ROD, accelerator, Petter PH2	1
4	10362A04		ROD, accelerator, Lister ST2	1
5	C163		BRACKET	1
6	C173D		SPRING	1
7	10S01		WASHER, flat	2
8	44S01C		PIN, split	2
9	74S02		NUT	2
9A	41S03		WASHER, Spring	1
10	C160B		BALL JOINT	1
11	11S03E		SCREW, set	2
12	7S03		NUT	4
13	17S04		WASHER, spring	2
14	10362A12		ROD, accelerator, Lister TS2 & TR2	1
14	10362A14		ROD, accelerator, Petter P600/2	1
15	11031A02		LEVER, Petter P600/2	1
16	11031A01		LEVER, Lister TS2 & TR2	1
16A	17S03		WASHER, spring	1
16B	11S02A		SCREW, set	1
17	43S03		BUSH, pedal	2
18	131S01		NIPPLE, grease	1
19	176S01		COVER, grease nipple	1

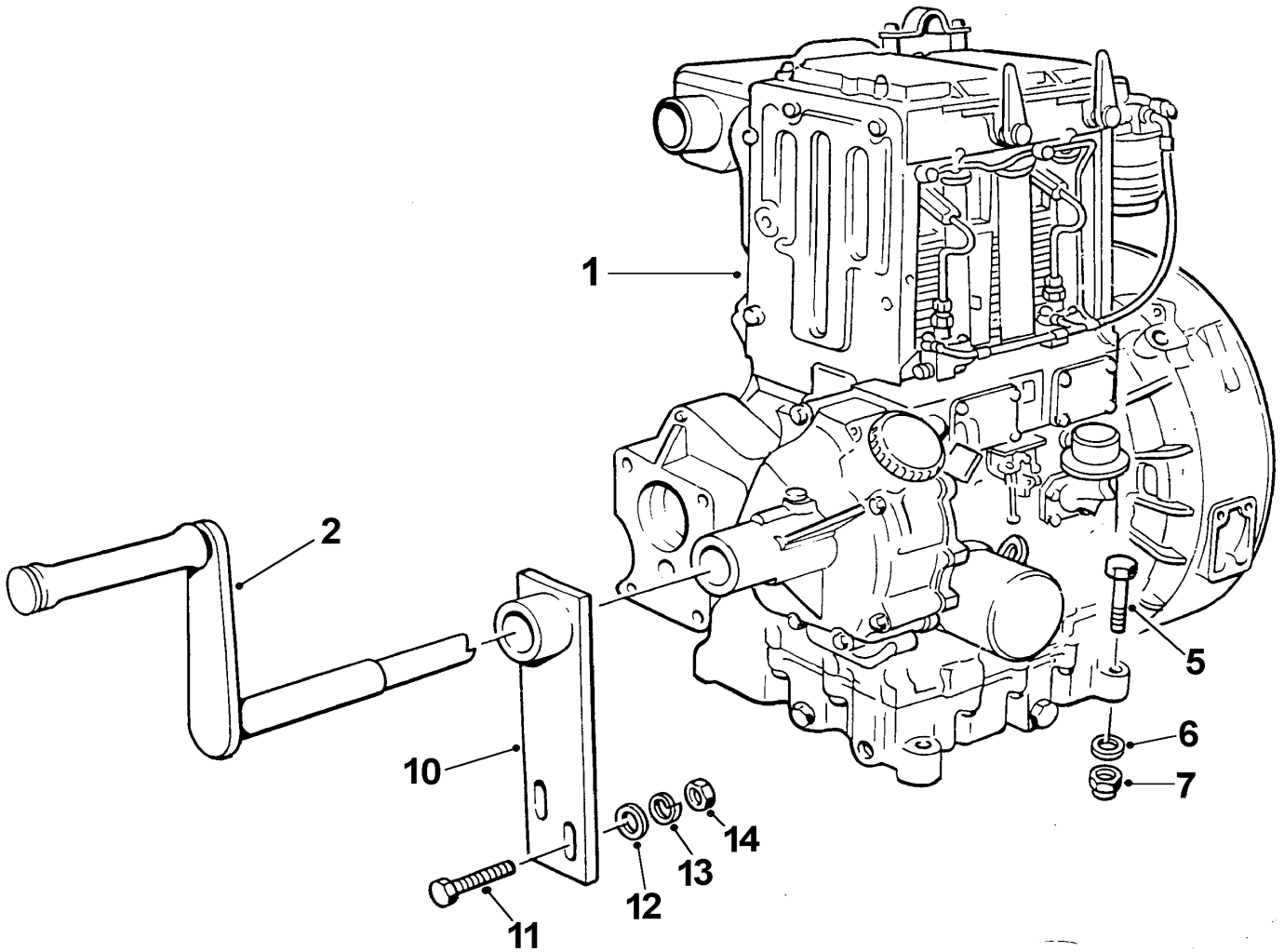

To order engine spares, please click below and refer to the relevant engine parts manual :

LISTER PETTER TS/TR

Item	Part no	Serial no	Description	Qty
------	---------	-----------	-------------	-----

**NOTE: For Petter P600/2 & PH2 and Lister ST2 engines
consult Winget Parts Department**

For Lister TR2 & TS2, see below.....

1	V2000762		ENGINE, TR2-07 (Electric start)	1
1	20350A02		ENGINE, TS2-07 (Electric start)	1
1	V2000761		ENGINE, TR2-06 (Hand start)	1
1	20350A01		ENGINE, TS2-06 (Hand start)	1
2	20354A01		HANDLE, engine starting	1
5	6S05J		BOLT	4
6	10S04		WASHER, flat	4
7	107S16		NUT, self-locking	4
10	20355A01		BRACKET. Starting handle	1
11	11S04E		BOLT	2
12	267S06		WASHER, flat	2
13	17S05		WASHER, spring	2
14	7S04		NUT	2

Electrics

STARTING & CHARGING CIRCUITS

Lister ST2	F - 1
-------------------	--------------

Lister TS2 & TR2	F - 1A
-----------------------------	---------------

Petter PH2	F - 2
-------------------	--------------

BATTERY, LEADS & INSTRUMENT PANEL

	F - 2A
--	---------------

ROAD LIGHTING CIRCUIT

<i>up to serial number 0862</i>	F - 3
--	--------------

<i>from serial number 0863</i>	F - 4
---------------------------------------	--------------

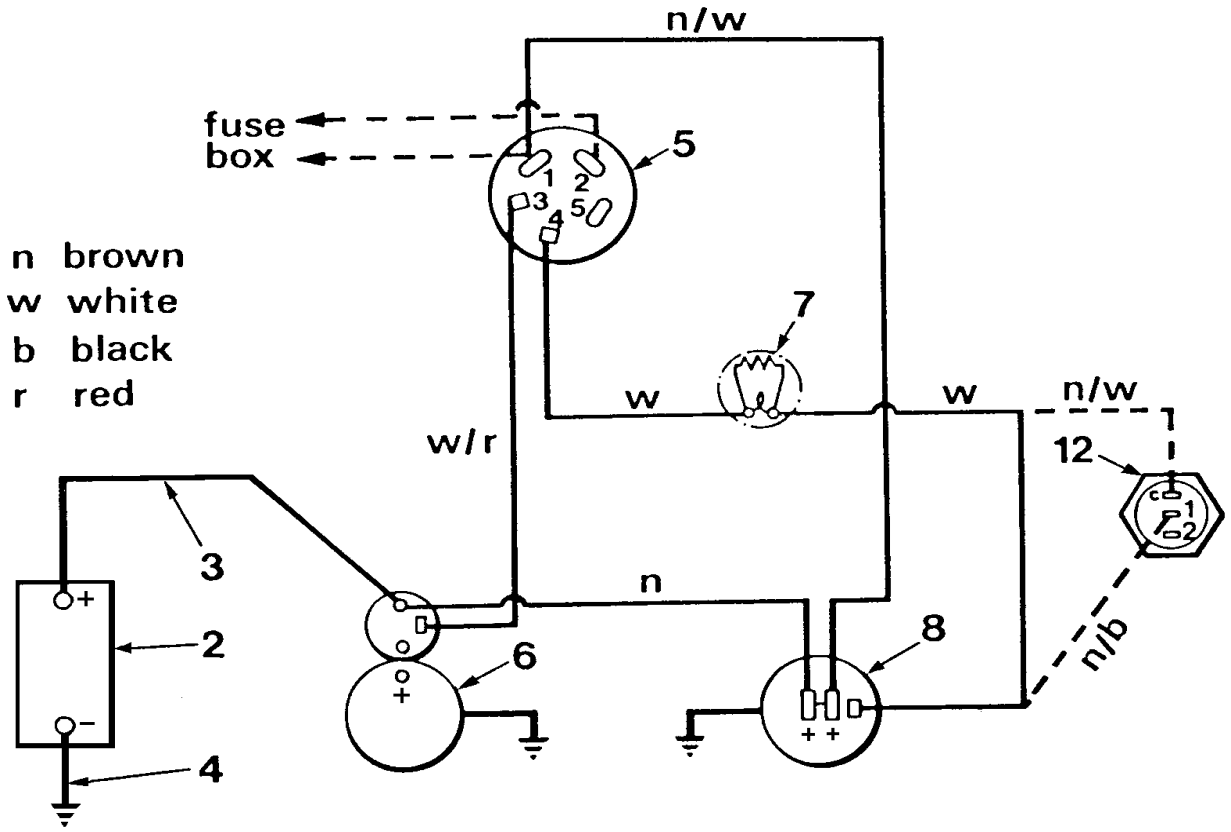

CHARGING & STARTING CIRCUIT

F - 1

Lister ST2

Item	Part no	Serial no	Description	Qty
1	30231A05		WIRING HARNESS	1
2	109S08		BATTERY	1
3	10989A01		CABLE, positive	1
4	10990A01		CABLE, negative	1
Items supplied with engine				
5	-		SWITCH, start	1
6	-		STARTER, c/w solenoid	1
7	-		LIGHT, warning, c/w excitor	1
8	-		ALTERNATOR	1
-	30178A04		GUARD (<i>alternative item - reference only. see Air Cleaner</i>)	
12	10964A01		SWITCH, pressure (<i>where fitted</i>)	1

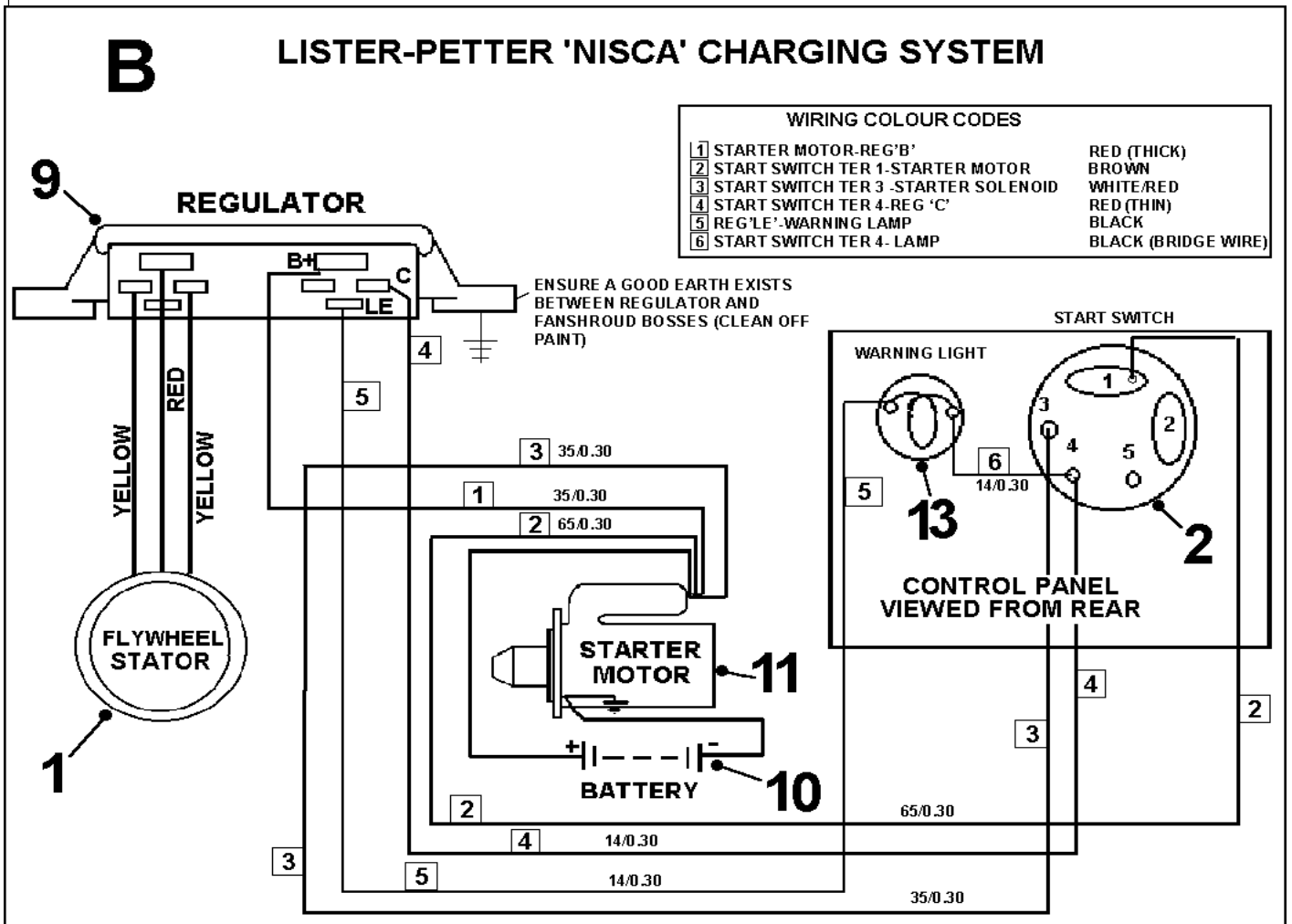
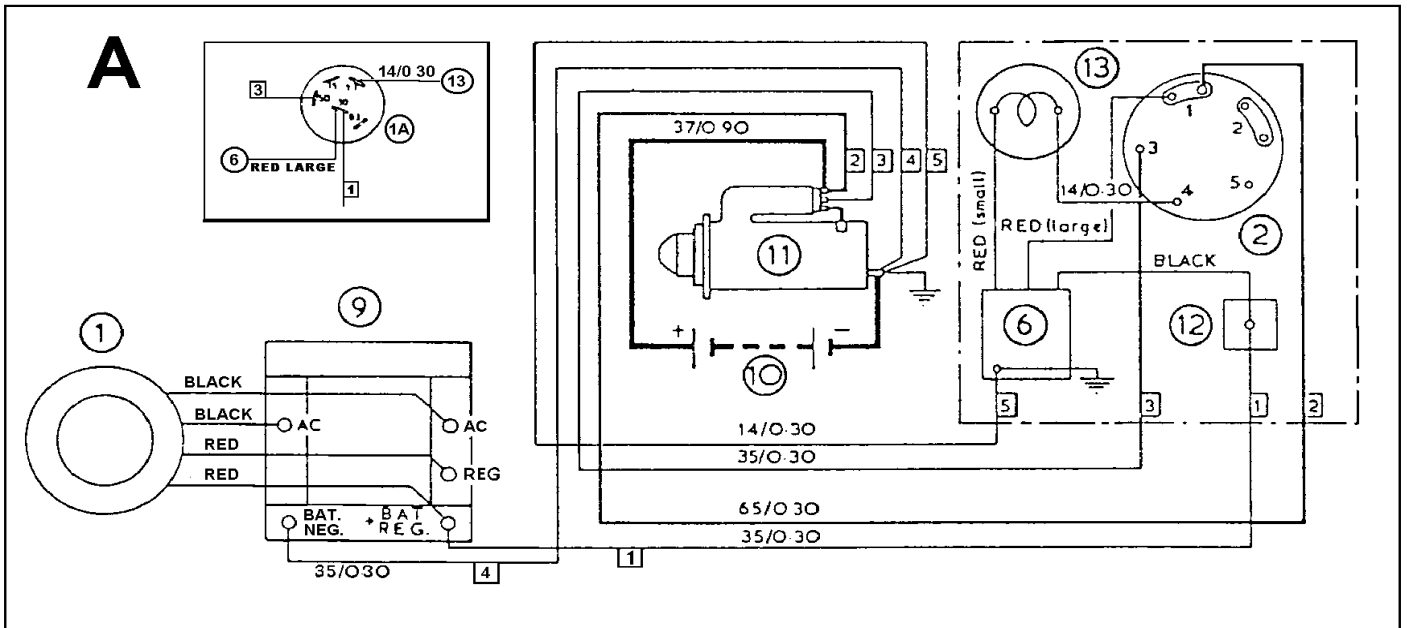

Lister TS2 & TR2

Item	Part no	Serial no	Description	Qty
------	---------	-----------	-------------	-----

NOTE: Up to February 1991, engines were fitted with 'Syncro' charging systems (see illustration **A**).
 From February 1991, engines were fitted with 'Nicsa' charging systems (see illustration **B**).
 The two systems are not interchangeable.
 Ascertain whether the engine is fitted with 'Syncro' or 'Nicsa' charging system before ordering parts.

Engines fitted with 'Syncro' charging system (illustration A)

1	-		# STATOR, flywheel alternator	1
2	V2004189		SWITCH, key start	1
6	-		# INDICATOR, battery charge	1
9	-		# RECTIFIER / REGULATOR	1
10	109S08		BATTERY	1
11	-		# STARTER MOTOR	1
13	V602634		LIGHT, warning	1
	- 30231A09		LOOM, wiring	1

Items supplied with engine.

For engine parts, see "Engine Parts Catalogue".

Engines fitted with 'Nicsa' charging system (illustration B)

1	366-08142		STATOR, flywheel alternator	1
1A	366-08143		ROTOR, flywheel alternator	1
2	V2004189		SWITCH, key start	1
9	366-08144		REGULATOR	1
9A	366-08145		CONNECTOR, regulator	1
10	109S08		BATTERY	1
11	570-30421		STARTER MOTOR	1
13	V602634		LIGHT, warning	1
	- 30231A11		LOOM, wiring	1

CHARGING & STARTING CIRCUIT

F - 2

Petter PH2

Item	Part no	Serial no	Description	Qty
-	30231A03		WIRING HARNESS	1
1	109S08		BATTERY	1
2	10989A01		CABLE, positive	1
3	10990A01		CABLE, negative	1
-	180S01		TIE, cable	AR
12	10961A01		LEAD, extension	1
13	10961A0101		PLUG	2

Items supplied with engine

4	-		SWITCH, start	1
5	-		AMMETER	1
6	-		STARTER, c/w solenoid	1
7	-		ALTERNATOR	1
8	-		SENSOR, temperature	1
9	-		SWITCH, pressure	1

The following items are not illustrated

-	30178A02		GUARD, alternator	1
-	10382A02		BRACKET, alternator guard	1
-	10382A03		BRACKET, alternator guard	1
-	63S02A		SCREW, guard fixing	4
-	17S03		WASHER, spring, guard fixing	4
-	12S02		WASHER, flat, guard fixing	4

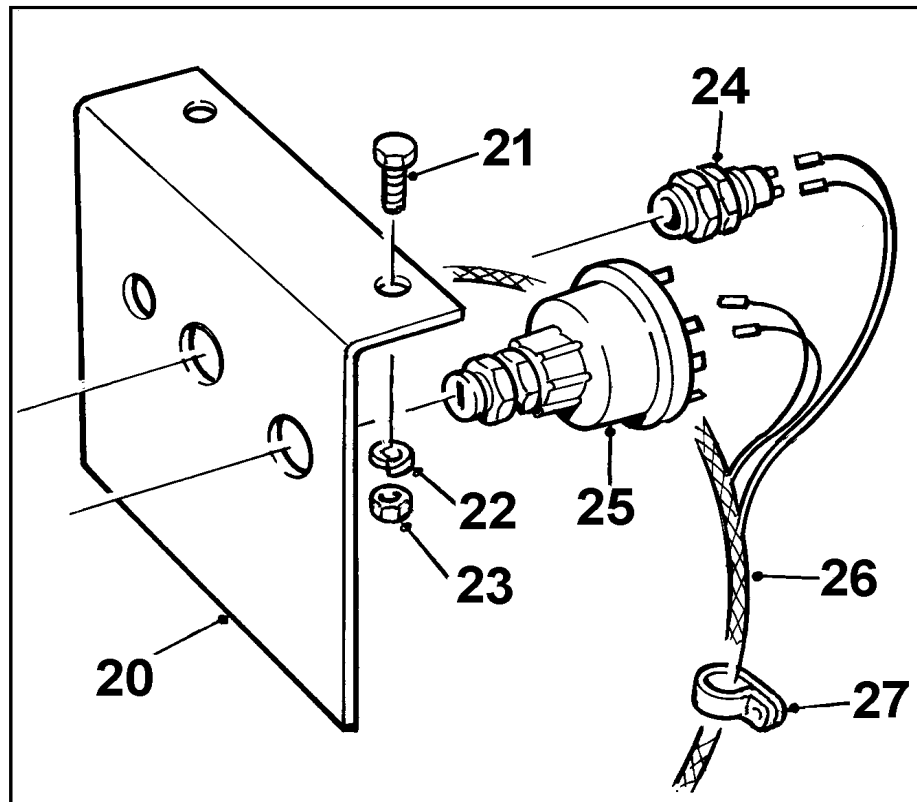
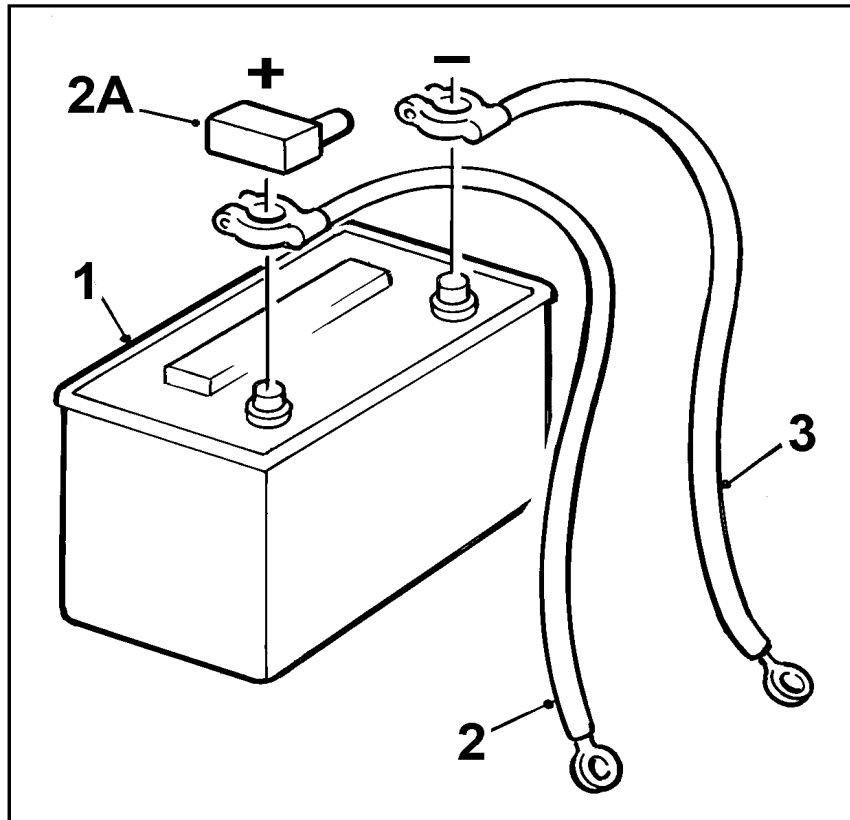

BATTERY, LEADS & INSTRUMENT PANEL
Lister TS2 & TR2 engines

F - 2A

Item	Part no	Serial no	Description	Qty
1	109S08		BATTERY	1
2	10989A01		CABLE, positive	1
2A	V2004204		INSULATOR, battery positive	1
3	10990A02		CABLE, negative	1
20	20313A05		PANEL, instrument	1
21	11S04B		SCREW, set	2
22	17S05		WASHER, spring	2
23	7S04		NUT	2
24	V602634		LIGHT, light warning	1
25	V2004189		SWITCH, engine start	1
26	30231A11		LOOM, wiring	1
27	V2003377		CLIP, loom	1

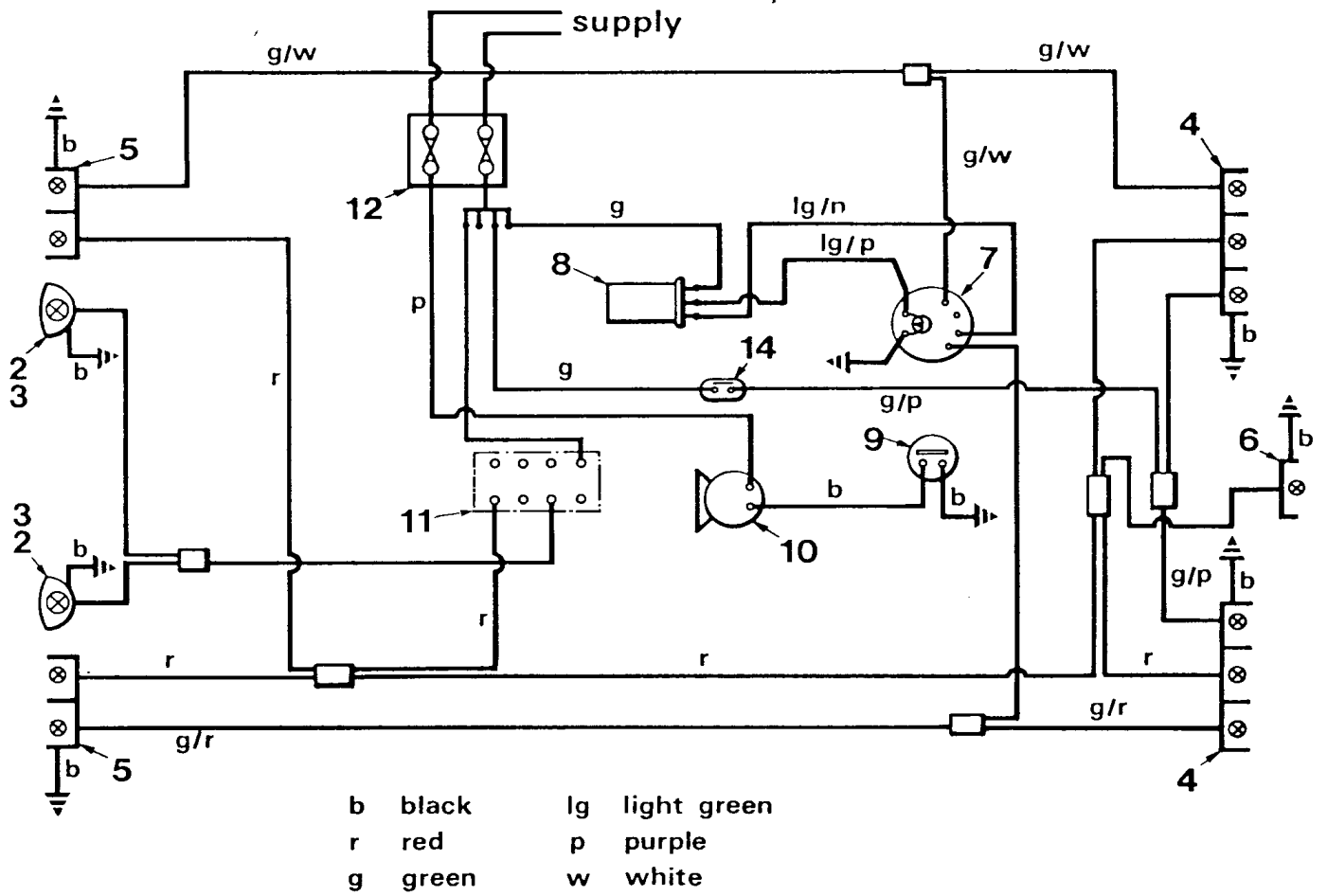

Item	Part no	Serial no	Description	Qty
-	20105A10	/ 0862	WIRING LOOM	1
2	20013A0112		HEADLAMP	2
3	10216A01		GUARD, stone	2
4	10512A02		LIGHT, rear/stop/indicator	2
5	10462A02		LIGHT, side/indicator	2
5	82S03E		SCREW	16
5	85S01		NUT	16
5	12S01		WASHER, flat	16
6	10615A01		LIGHT, number plate	1
7	10617A01		SWITCH, indicator	1
7	82S07C		SCREW	2
7	85S03		NUT	2
8	10616A01		FLASHER UNIT	1
8	82S03C		SCREW	1
8	12S01		WASHER, flat	1
8	85S01		NUT	1
9	10619A01		BUTTON, horn	1
9	82S07E		SCREW	2
9	85S03		NUT	2
10	10618A01		HORN	1
11	10620A01		SWITCH, light	1
12	10644A01		FUSE BOX	1
12	82S03E		SCREW	1
12	85S01		NUT	1
-	180S01		TIE, cable	AR
14	10387A01		ADAPTOR, brake switch	1
-	116S02		WASHER	1
-	8S02A		BOLT	2
-	7S02		NUT	2
-	12S14		WASHER, flat	2
-	10744A01		SWITCH, brake, mineral oil brakes	1
-	10939A02		SWITCH, brake, vegetable oil brakes	1

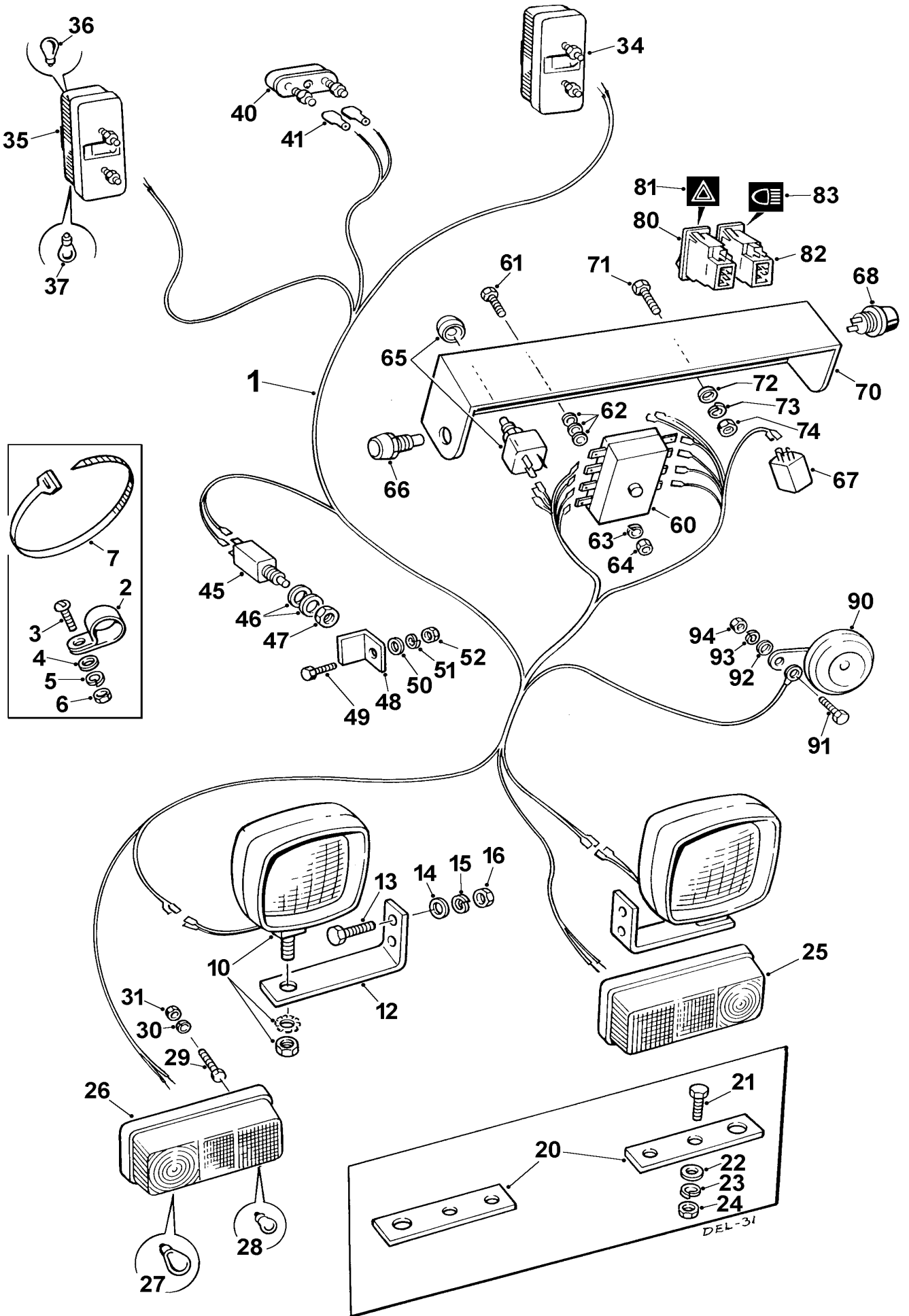

Item	Part no	Serial no	Description	Qty
1	20105A16	0863 /	LOOM, wiring	1
2	143200900		CLIP, 'P', nylon	10
3	16S05B		SCREW, set	10
4	267S02		WASHER, flat	10
5	17S10		WASHER, spring	10
6	7S09		NUT	10
7	V2003111		TIE, cable (200mm long)	35
7	V2003253		TIE, cable (400mm long)	6
10	V2003638		LIGHT, head	2
12	11038A01		BRACKET, head light	2
13	11S05H		SCREW, set	4
14	267S07		WASHER, flat	4
15	17S06		WASHER, spring	4
16	7S06		NUT	
20		BRACKET, (<i>make from bracket 11038A01 for dumpers with high discharge or rotating skips</i>)	
21	11S03E		SCREW, set	4
22	267S05		WASHER, flat	4
23	17S04		WASHER, spring	4
24	7S03		NUT	4
25	V2003637		LIGHT, front L/H. assembly	1
26	V2003652		LIGHT, front R/H. assembly	1
27		BULB, indicator, 12V 21W	1
28		BULB, sidelight, 12V 5W	1
29	11S01C		SCREW, set	2
30	17S02		WASHER, spring	2
31	7S01		NUT	2
34	V2003636		LIGHT, rear L/H. assembly	1
35	V2003651		LIGHT, rear R/H. assembly	1
36		BULB, indicator, 12V 21W	1
37		BULB, brake/rear side, 12V 21/5W	1
40	V2003639		LIGHT, number plate	1
41	191906000		CONNECTOR, Lucar 1/4" female	2
45	V2003168		SWITCH, brake light	1
46	10S04		WASHER, flat	2
47	95S05		NUT, brake light switch	1

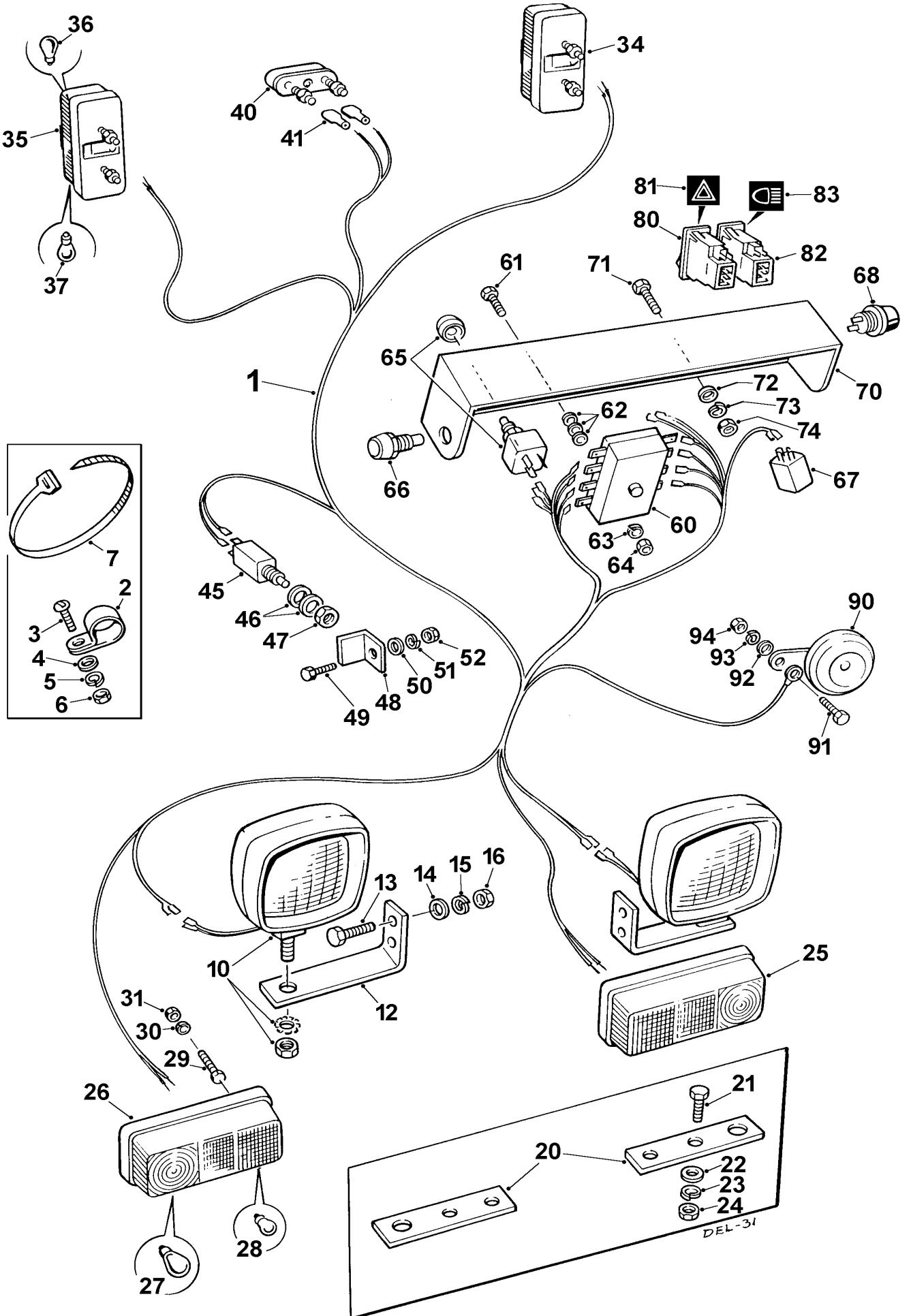

ROAD LIGHTING CIRCUIT

5 - B - 2

Item	Part no	Serial no	Description	Qty
48	V2004768		BRACKET, brake light switch.	1
49	11S03C		SCREW, set	1
50	267S05		WASHER, flat	1
51	17S04		WASHER, spring	1
52	7S03		NUT	1
60	V2003176		FUSE BOX, obsolete use item 60A	1
60A	V601177		FUSE BOX	1
60B	V2003177		FUSE, bullet, use with item 60	AR
60C	V601173		FUSE, blade, use with item 60A	AR
61	11S01A		SCREW, set	2
62	267S03		WASHER, flat	6
63	17S02		WASHER, spring	2
64	7S01		NUT	2
65	V2003642		SWITCH, direction indicators	1
66	V2000326		LIGHT, warning Indicator	1
67	V2003640		UNIT, flasher	1
68	V2003570		BUTTON, horn	1
70	20313A11		PANEL, instruments	1
71	11S02B		SCREW, set	2
72	267S04		WASHER, flat	2
73	17S03		WASHER, spring	2
74	7S02		NUT	2
80	V2003641		SWITCH, hazard lights	1
81	V2006347		INSERT, hazard lights	1
82	V2003644		SWITCH, lights	1
83	V2003646		INSERT, mainbeam	1
90	V2003144		HORN	1
91	11S03B		SCREW, set	1
92	267S05		WASHER, flat	1
93	17S04		WASHER, spring	1
94	7S03		NUT	1

Hydraulics

MAIN HYDRAULIC CIRCUIT Standard & High Discharge Skips, Manual Rot Skip	H - 1
MAIN HYDRAULIC CIRCUIT For hydraulic rotating skip	H - 1AA
TIPPING HYDRAULIC CIRCUIT For hydraulic rotating skip	H - 1AB
ROTATING HYDRAULIC CIRCUIT For hydraulic rotating skip	H - 1AC
PUMPS with adaptors	H - 1A
PUMPS with flange plate fittings	H - 1B
HYDRAULIC PUMP, direct drive from serial no. 1704	H - 1BB
CONTROL VALVE, <i>up to January 1988</i>	H - 1C
CONTROL VALVE, sectional	H - 2
SECTION, control valve	H - 3
CONTROL VALVE, monobloc	H - 4
CONTROL VALVE, joystick	H - 4A
RAM, steering <i>up to serial no. 0981</i>	H - 5
<i>from serial no. 0982</i>	H - 5A
RAM, skip tipping, Earth skip <i>up to serial no. 1033</i>	H - 6
Earth skip <i>from serial no. 1034</i>	H - 6A
High discharge skip	H - 7
Manual rotating skip	H - 8
Hydraulic rotating skip	H - 9
RAM, swivel, hydraulic rotating skip	H - 10

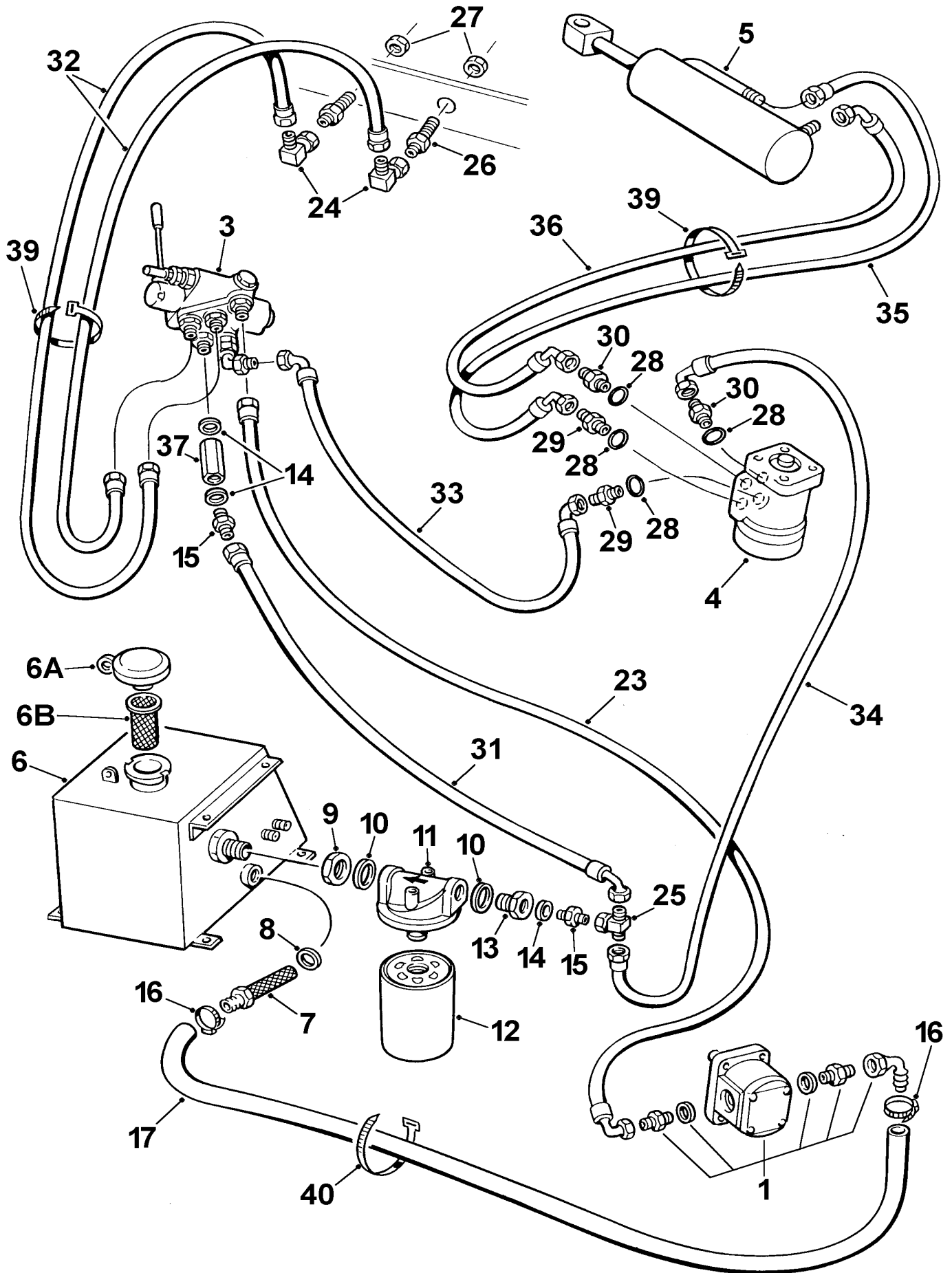

MAIN HYDRAULIC CIRCUIT, non hydraulic rotating skip H - 1

Item	Part no	Serial no	Description	Qty
STANDARD EARTH, HIGH DISCHARGE & MANUAL ROTATING SKIPS				
1		PUMP & FITTINGS (<i>see H-1A & H-1B</i>)	
3		VALVE, control (<i>see Section Index</i>)	1
4		VALVE, steer (<i>see page B - 2</i>)	1
5		RAM, steering (<i>see Section Index</i>)	1
6	40282A04		TANK, hydraulic oil	1
6A	10378A03		CAP, tank	
6B	10379A03		FILTER/STRAINER	1
7	901S01		FILTER/STRAINER	1
8	186S14		SEAL, nylon. Obsolete: use 100S08	1
8	100S08		SEAL, bonded	1
9	72S07		NUT, locking	1
10	100S09		SEAL, bonded	2
11	10363A03		HEAD, filter	1
12	10363A02		ELEMENT, filter	1
13	111S01		FITTING, reducing	1
14	100S04		SEAL, bonded	3
15	119S08		FITTING, adaptor	1
16	V2003232		CLIP, hose	2
17	37S03		HOSE, suction (<i>order by metre</i>)	AR
17	37S03BJ		HOSE, suction (<i>TS2 & TR2 only</i>)	1
Items 18,19,20 & 21 not illustrated, used when DD PTO is fitted, Page H-1BB				
18	V2003559		CLIP, hose	2
19	11S04C		SCREW, set	1
20	17S05		WASHER, spring	1
21	267S06		WASHER, flat	1
23	31S02K		HOSE, pump (<i>Petter P600/2</i>)	1
23	31S02Q		HOSE, pump (<i>Petter PH2</i>)	1
23	31S02J	/ 0749	HOSE, pump (<i>Lister ST2, TS2 & TR2</i>)	1
23	31S03I	0759/	HOSE, pump (<i>Lister ST2, TS2 & TR2</i>)	1
24	96S09		FITTING, elbow, compact	2
25	154S09		FITTING, tee	1

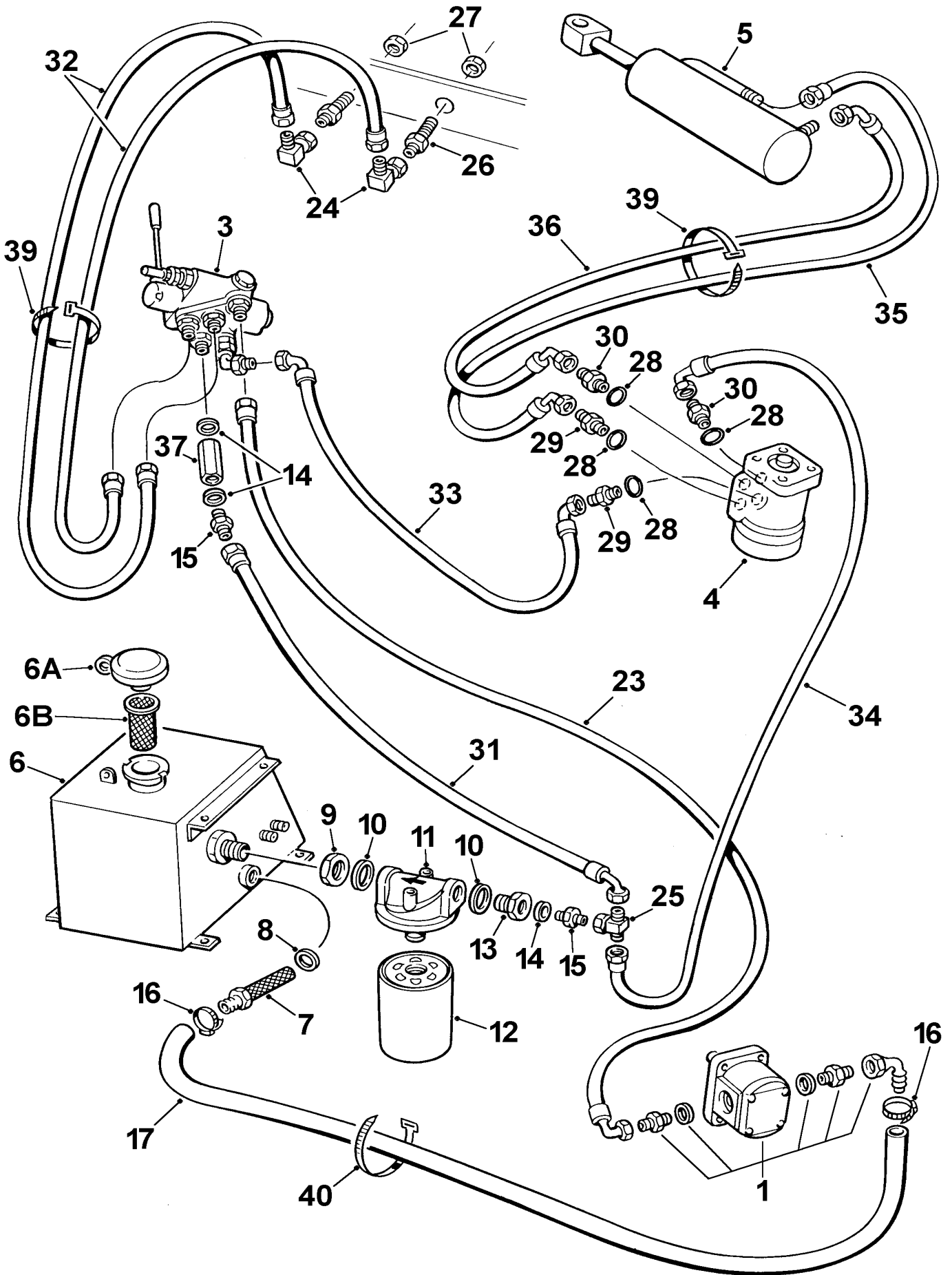

MAIN HYDRAULIC CIRCUIT, non hydraulic rotating skip H - 1

Item	Part no	Serial no	Description	Qty
STANDARD EARTH, HIGH DISCHARGE & MANUAL ROTATING SKIPS				
26	93S01		ADAPTOR, bulkhead	2
27	72S01		NUT, locking	2
28	49S02		SEAL, 'O' ring	4
29	126S04		ADAPTOR, male/male	2
30	460115		FITTING, extended	2
31	31S02V		HOSE, check valve to Tee	1
32	35S02AE		HOSE, control v. to bulkhead fittings	2
33	36S02B		HOSE, control v. to steer v.	1
34	31S02E		HOSE, steer v. to return Tee	1
35	31S02J		HOSE, steer v. to steer ram RETRACT	1
36	36S02HH		HOSE, steer v. to steer ram EXTEND	1
37	10979A02		VALVE, check	1
39	V2003111		TIE, cable, nylon	3
40	V2003253		TIE, cable, nylon	3

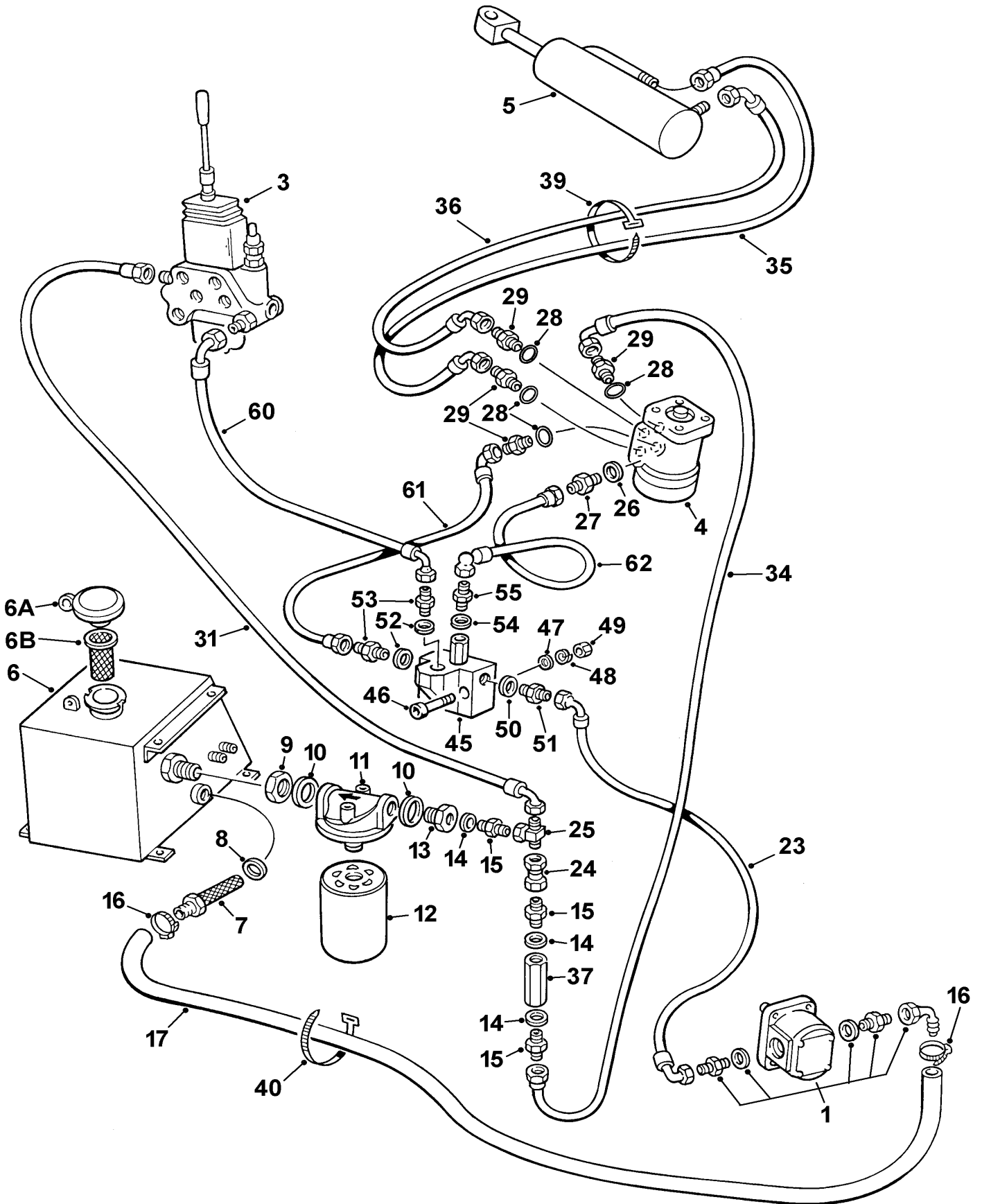

MAIN HYDRAULIC CIRCUIT, hydraulic rotating skip

H - 1AA

Item	Part no	Serial no	Description	Qty
1		PUMP & FITTINGS (see <i>H-1A & H-1B</i>)	
3		VALVE, control (see <i>Section Index</i>)	1
4		VALVE, steer (see <i>page B - 2</i>)	1
5		RAM, steering (see <i>Section Index</i>)	1
6	40282A04		TANK, hydraulic oil	1
6A	10378A03		CAP, tank	
6B	10379A03		FILLER/STRAINER	1
7	901S01		FILTER/STRAINER	1
8	100S08		SEAL, bonded	1
9	72S07		NUT, locking	1
10	100S09		SEAL, bonded	2
11	10363A03		HEAD, filter	1
12	10363A02		ELEMENT, filter	1
13	111S01		FITTING, reducing	1
14	100S04		SEAL, bonded	3
15	119S08		FITTING, adaptor	1
16	V2003232		CLIP, hose	2
17	37S03BJ		HOSE, suction	1
23	63S03J		HOSE, pump to priority valve	1
24	164S03		FITTING, female/female swivel	1
25	154S09		FITTING, tee	1
26	100S02		SEAL, bonded	1
27	122S02		ADAPTOR, male/male	1
28	100S04		SEAL, bonded	4
29	119S08		ADAPTOR, male/male	4
31	31S02V		HOSE, control valve (return) to Tee	1
34	31S02E		HOSE, steer valve to check valve	1
35	31S02J		HOSE, steer v. to steer ram RETRACT	1
36	36S02HH		HOSE, steer v. to steer ram EXTEND	1

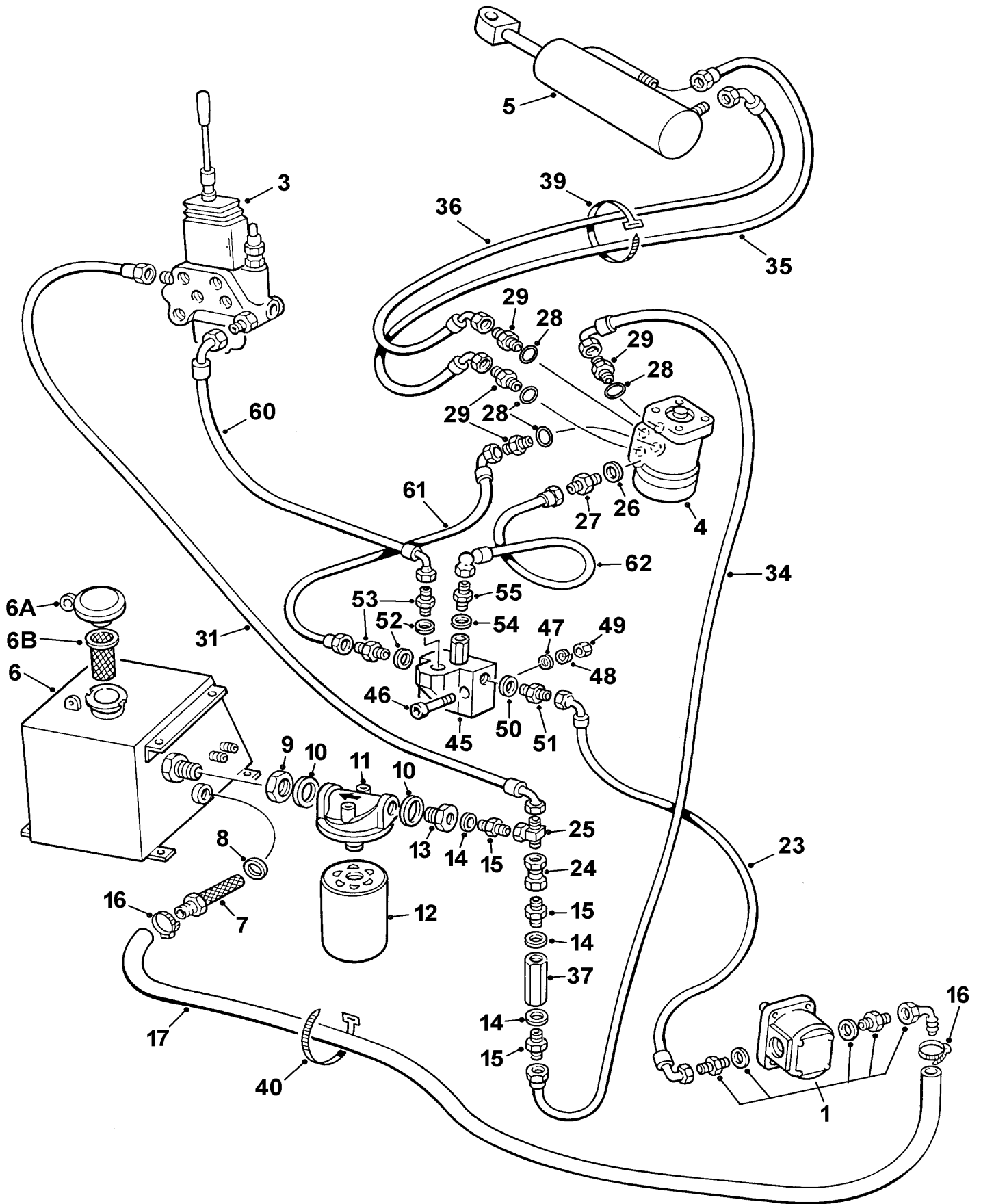

MAIN HYDRAULIC CIRCUIT, hydraulic rotating skip**H - 1AA**

Item	Part no	Serial no	Description	Qty
37	10979A02		VALVE, check	1
39	V2003111		TIE, cable, nylon	3
40	V2003253		TIE, cable, nylon	3
45	V2005153		VALVE, priority	1
46	68S05M		SCREW, cap head	2
47	267S06		WASHER, flat	2
48	17S05		WASHER, spring	2
49	7S04		NUT	2
50	100S04		SEAL, bonded	1
51	122S04		ADAPTOR, male/male	1
52	100S04		SEAL, bonded	2
53	119S08		ADAPTOR, male/male	2
54	100S02		SEAL, bonded	1
55	122S02		ADAPTOR, male/male	1
60	36S02B		HOSE, priority v. to control v. (supply)	1
61	63S03D		HOSE, priority v. to steer v. (supply)	1
62	53S01D		HOSE, priority v. to steer v.(load sensing)	

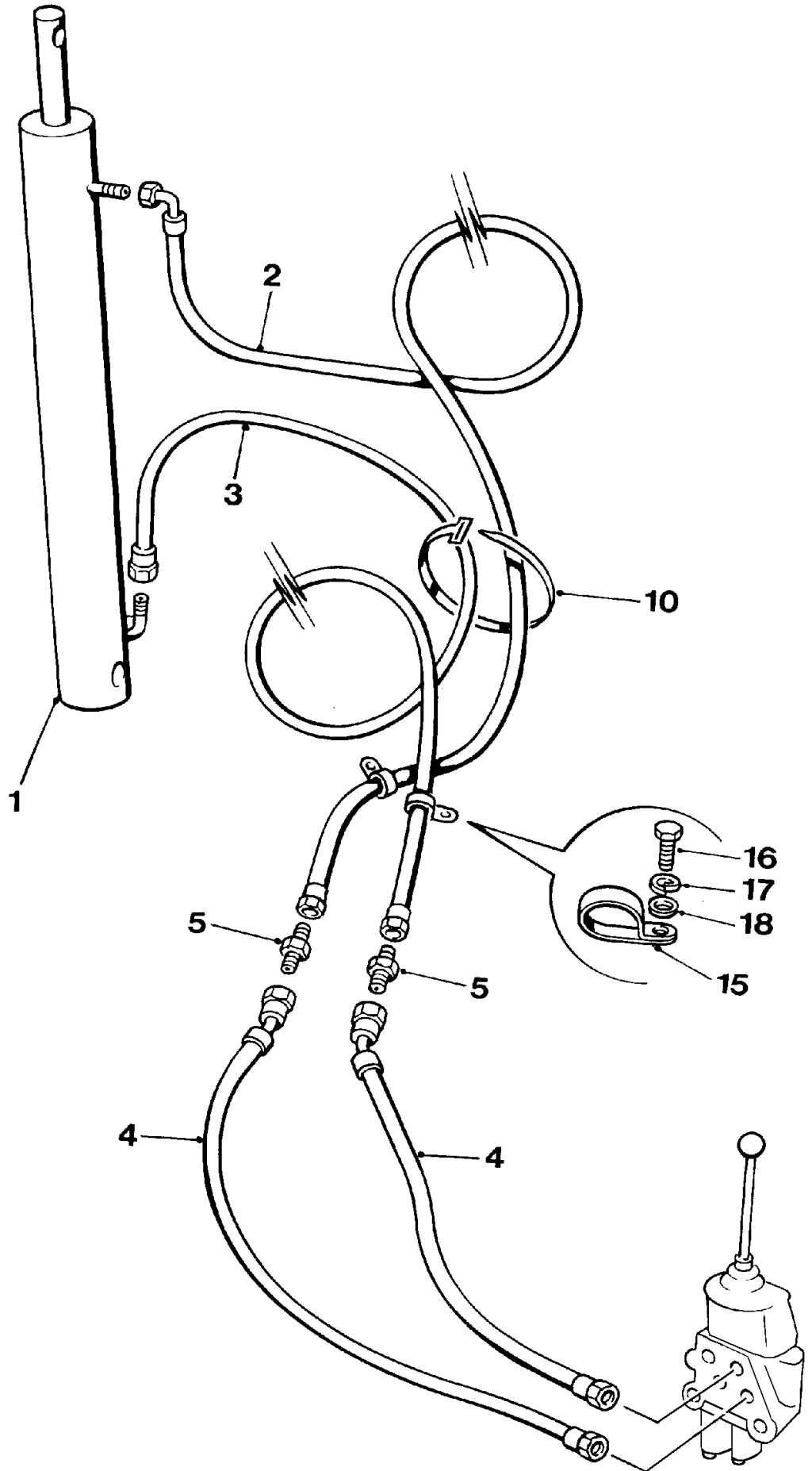

TIPPING HYDRAULIC CIRCUIT
hydraulic rotating skip

H - 1AB

Item	Part no	Serial no	Description	Qty
1	30113A06		RAM, tipping (see page H - 9)	1
2	318S02F		HOSE, front chassis, skip DOWN	1
3	321S02A		HOSE, front chassis, skip UP	1
4	317S02B		HOSE, rear chassis	2
5	122S03		ADAPTER	2
10	V2003253		TIE	6
15	V2004537		CLIP, hose	2
16	11S03C		SCREW, set	2
17	17S04		WASHER, spring	2
18	267S05		WASHER, flat	2

H - 1AC

4B2000 Dumper

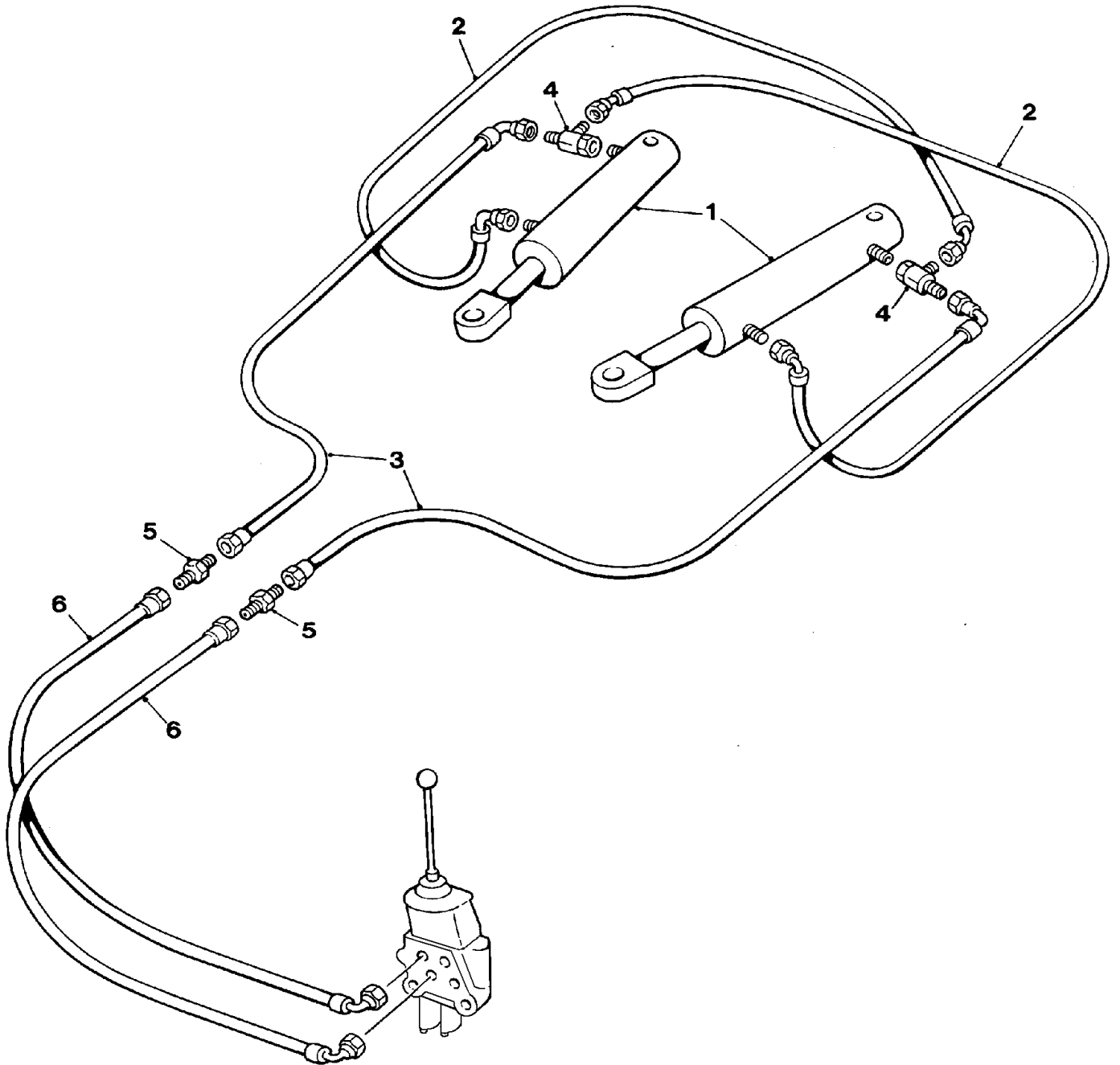

ROTATING HYDRAULIC CIRCUIT
hydraulic rotating skip

H - 1AC

Item	Part no	Serial no	Description	Qty
1	30287A03		RAM, rotating (<i>see page H - 10</i>)	2
2	320S01C		HOSE, ram to ram	2
3	32S01C		HOSE, front chassis	2
4	154S01		FITTING, 'Tee' piece, m/m/f swivel	2
5	122S02		ADAPTER, m/m	2
6	318S01D		HOSE, rear chassis	2
.....	V2003111		TIE, cable, nylon (<i>not illustrated</i>)	3
.....	V2003253		TIE, cable, nylon (<i>not illustrated</i>)	3

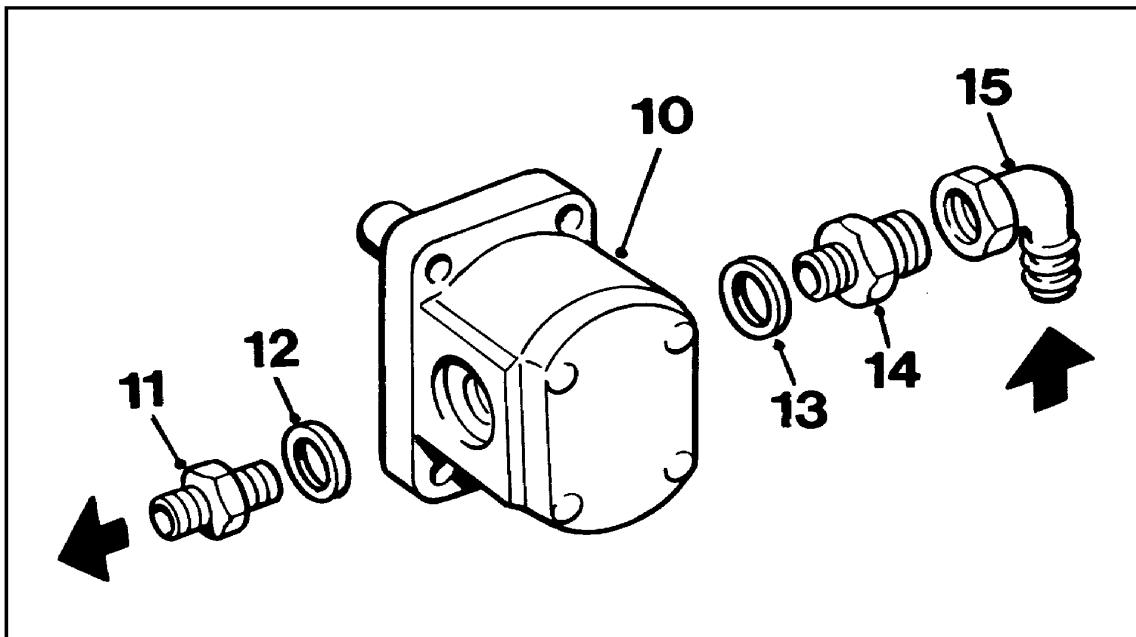
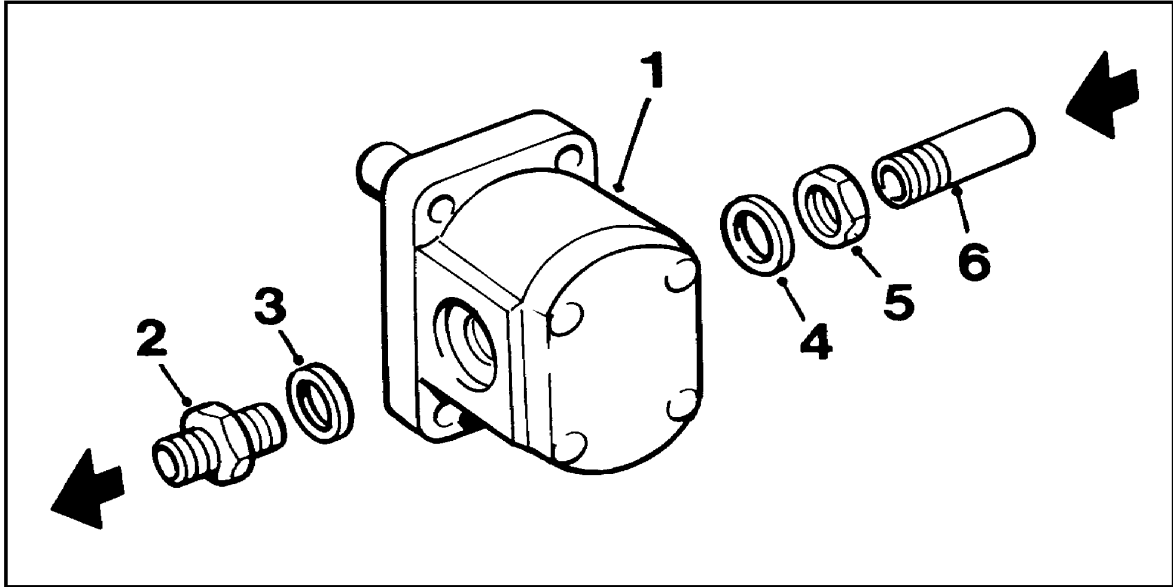

Item	Part no	Serial no	Description	Qty
<p>When ordering a hydraulic pump, state whether DOWTY', 'ULTRA', or "SUNDSTRAND" as indicated on the pump casing or serial plate.</p>				
<p>Dumpers with Petter PH2 & P600/2 or Lister ST2 engines</p>				
1	10535A03		# PUMP, 'DOWTY', Petter P600/2	1
1	11041A06		# PUMP, 'SUNDSTRAND', Petter P600/2	1
1	10535A02		# PUMP, 'DOWTY', Petter PH2	1
1	11041A05		# PUMP, 'SUNDSTRAND', Petter PH2	1
1	10539A02		# PUMP, 'DOWTY', Lister ST2	1
1	11041A02		# PUMP, 'SUNDSTRAND', Lister ST2 # (pumps have 3/4" inlet & 3/4" outlet)	1
2	119S10		ADAPTOR, (outlet)	1
3	100S06		SEAL, bonded	1
4	186S12		SEAL, nylon	1
5	72S03		NUT	1
6	10910A01		PIPE, stub, (inlet)	1
<p>Dumpers with Lister Petter TS2 or TR2 engines</p>				
10	10539A03		PUMP, 'Dowty' or 'Ultra', Clockwise TS/TR2 (pump has 3/4" inlet & outlet)	1
10	10539A02		PUMP, 'Dowty', Anti-Clockwise TS/TR2 (pump has 3/4" inlet & outlet) Used with direct drive PTO, page H-1BB	1
11	119S13		ADAPTOR, (outlet)	1
12	100S06		SEAL, bonded	2
13	100S06		SEAL, bonded	1
14	119S15		ADAPTOR, 3/4"x1" BSP (inlet)	1
15	V2003053		ELBOW, 135 ^o , 1" BSP	1
15	129S06F		ELBOW, 90 ^o , 1" BSP Used with direct drive PTO, page H-1BB	1
10	11041A03		\$ PUMP, 'SUNDSTRAND', Lister TS2 & TR2 (pump has 3/4" inlet & 1/2" outlet) \$ Obsolete: use pump kit 10539A04	
.....	10539A04		KIT, PUMP & FITTINGS Replacement for 11041A03	1
11	122S04		ADAPTOR, (outlet)	1
12	100S04		SEAL, bonded	2
13	100S06		SEAL, bonded	1
14	119S15		ADAPTOR, 3/4"x1" BSP (inlet)	1
14	122S07		ADAPTOR, 1"x1" BSP (inlet)	1
15	V2003053		ELBOW, 135 ^o , 1" BSP	1
15	129S06F		ELBOW, 90 ^o , 1" BSP	1

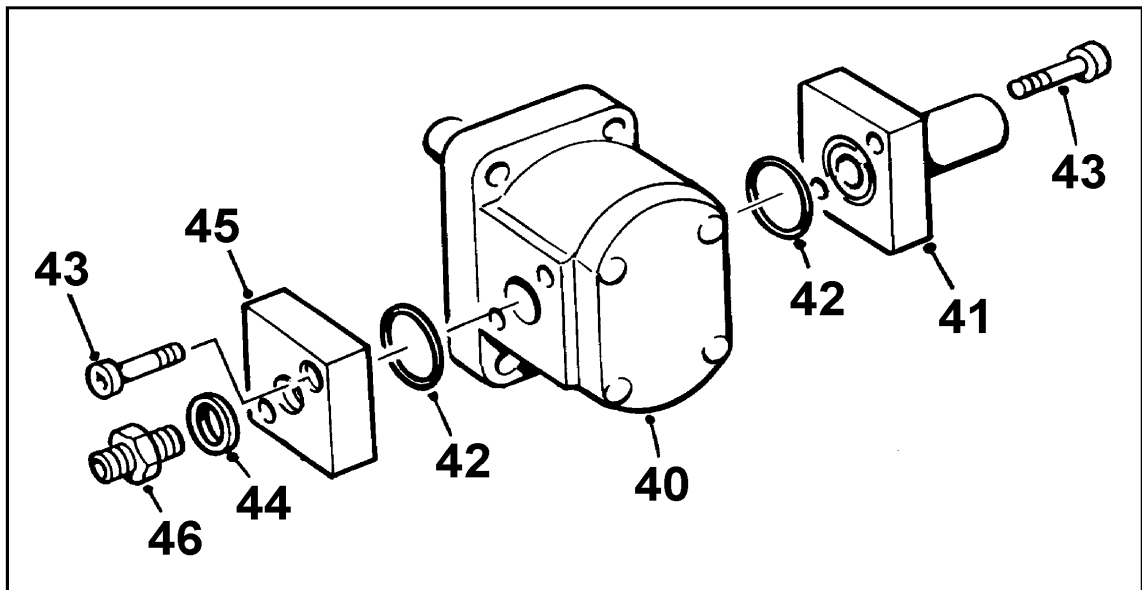

PUMPS with flange plate fittings

H - 1B

Item	Part no	Serial no	Description	Qty
40	10535A01		PUMP, 'DOWTY', Petter PH2	1
40	11041A04		PUMP, 'SUNDSTRAND', Petter PH2	1
40	10539A01		\$ PUMP, 'DOWTY', Lister ST2	1
40	11041A01		\$ PUMP, 'SUNDSTRAND', Lister ST2	1
			\$ <i>Obsolete: use pump kit 10539A04 see previous page.</i>	
			<i>However, the following flanges and fittings are available.....</i>	
41	10475A03		PLATE, inlet (suction)	1
42	49S11		SEAL, 'O' ring	2
43	103S03C		SCREW, cap	4
44	100S03		SEAL, bonded	1
45	435261		PLATE, outlet (supply)	1
46	122S03		ADAPTOR, male/male	1

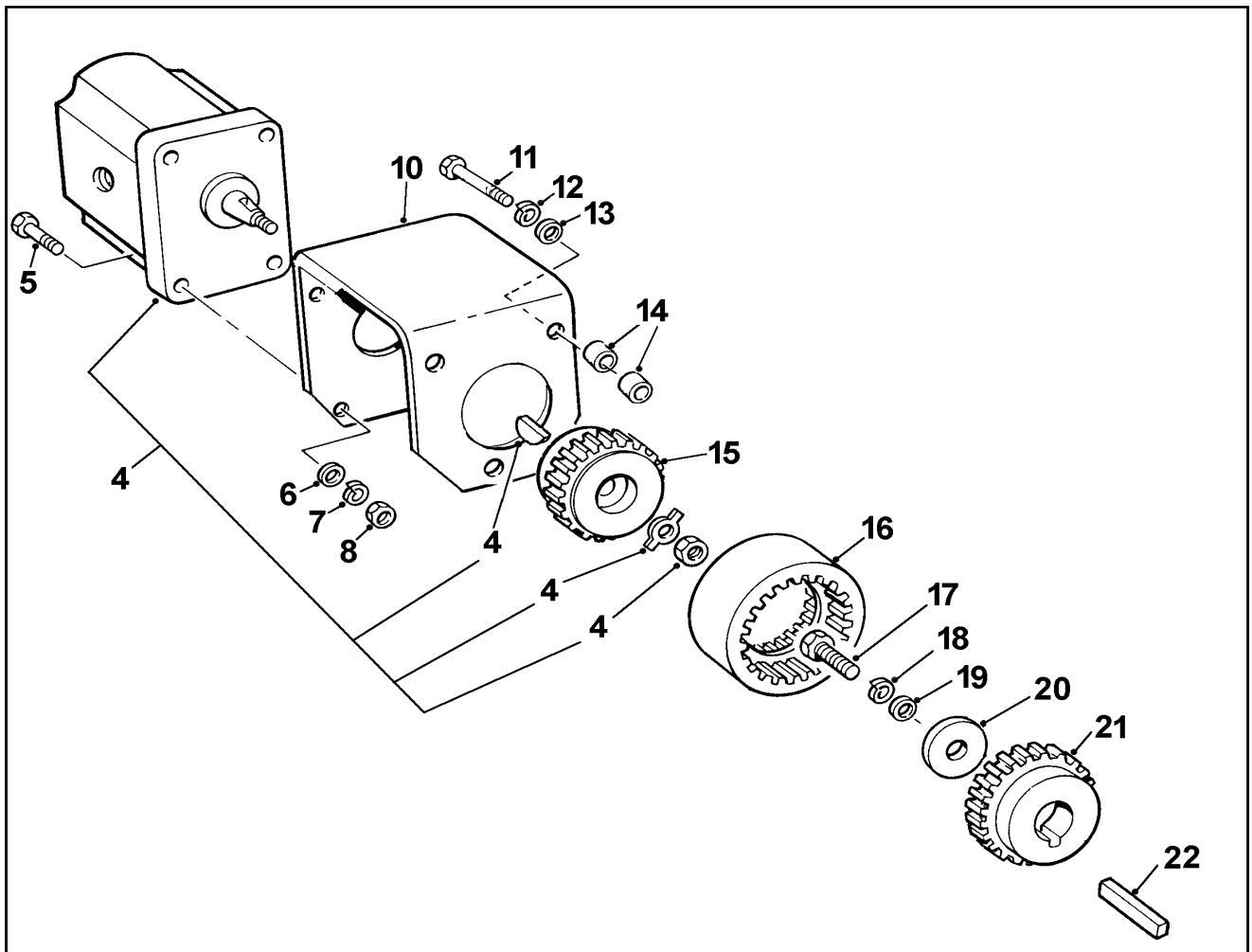
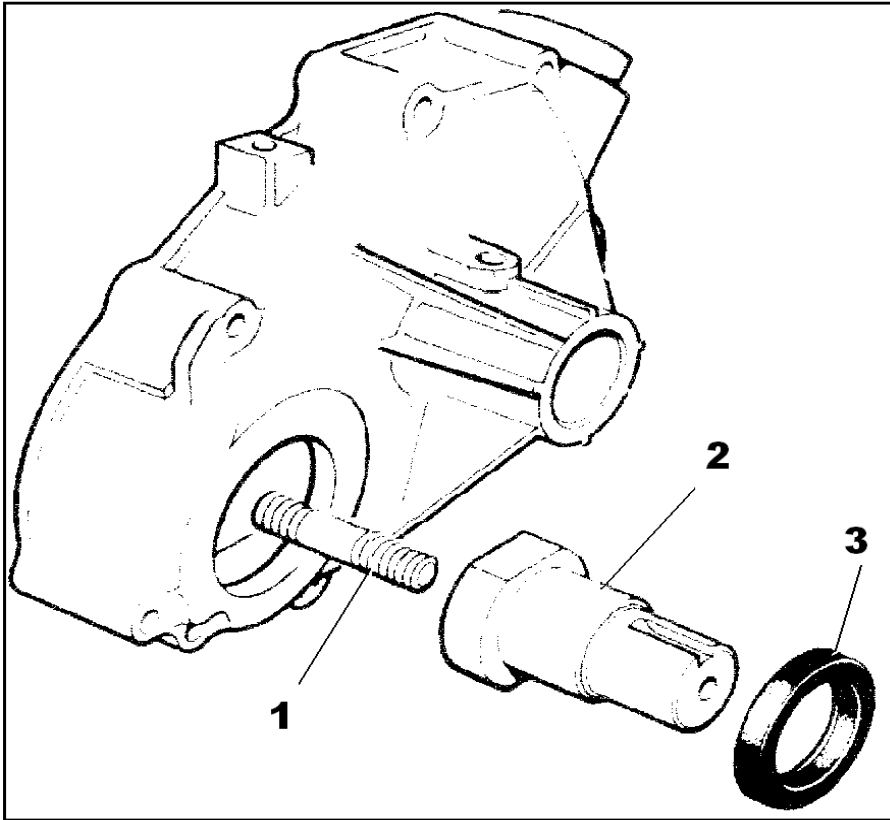

HYDRAULIC PUMP, direct drive from serial no 1704

H - 1BB

Item	Part no	Serial no	Description	Qty
1	V2006390		STUD	1
2	V2006381		EXTENSION SHAFT, pump drive	1
3	417732500		SEAL, oil	1
4	10539A02		PUMP, hydraulic, anti-clockwise rot	1
<i>For pump adaptors refer to page H1A</i>				
5	8S02C		BOLT	4
6	267S04		WASHER, flat	4
7	17S03		WASHER, spring	4
8	7S02		NUT	4
10	V2006385		BRACKET, pump mounting	1
11	8S03N		BOLT	3
12	17S04		WASHER, spring	3
13	267S05		WASHER, flat	3
14	513340800		SPACER	6
15	V2006383		COUPLING, driven half, pump	1
16	V603660		SLEEVE COUPLING, nylon	1
	V2006389		COUPLING ASSEMBLY	1
<i>comprises of items 15, 16, & 21</i>				
17	11S03B		SCREW, set	1
18	17S04		WASHER, spring	1
18	267S05		WASHER, flat	1
20	V2004220		WASHER SPECIAL, flat	1
21	V2006384		COUPLING, drive half, engine shaft	1
22	305110550		KEY, parallel, (cut to length)	1
<i>Following parts are not illustrated</i>				
23	V2006388		GUARD, coupling	1
24	11S03B		SCREW, set	1
25	17S04		WASHER, spring	1
26	267S05		WASHER, flat	1

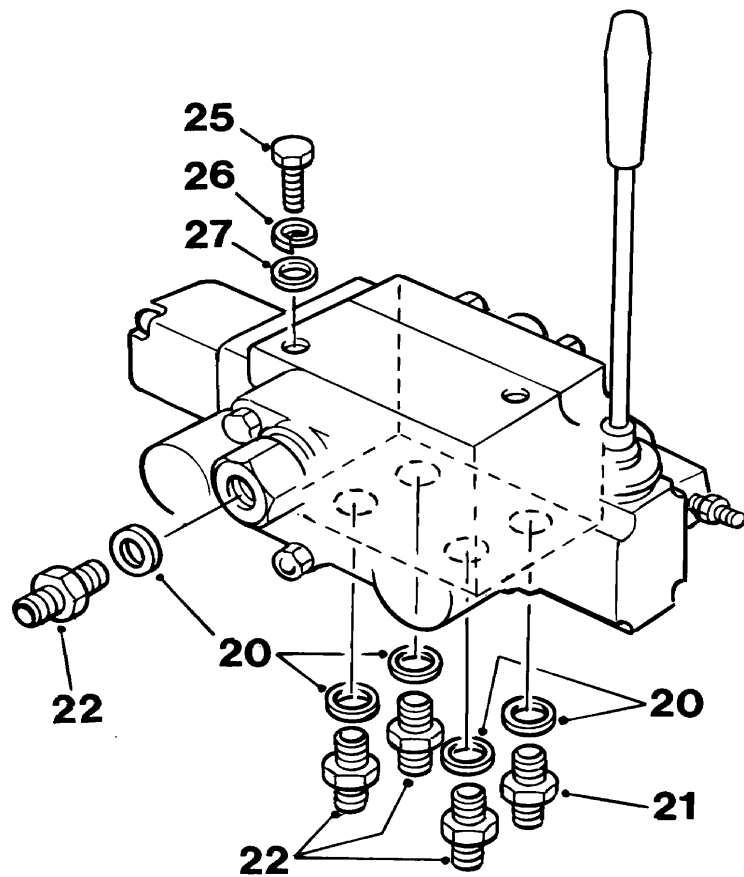
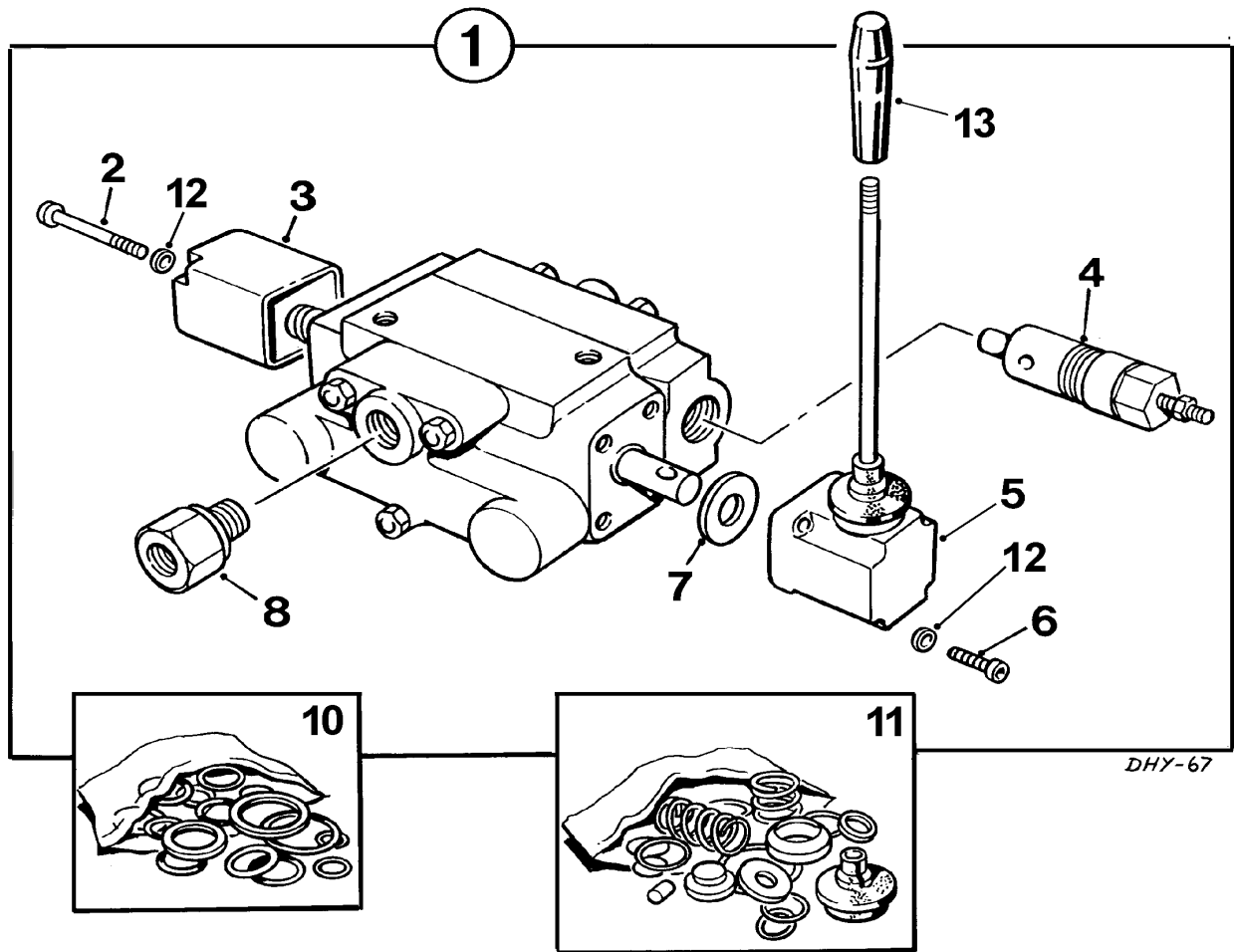

CONTROL VALVE (up to January 1988)**H - 1C**

Item	Part no	Serial no	Description	Qty
1	30322A05	/ Jan 88	CONTROL VALVE	1
2	30322A0502		SCREW, socket cap head	2
3	30322A0204		CAP, end	1
4	30322A0102		VALVE, relief	1
5	30322A0503		HANDLE, assembly	1
6	68S02B		SCREW, socket cap head	4
7	10S05		SPACER, washer	1
8	30322A0504		ADAPTOR	1
10	451441502		KIT, seals	1
11	30322A0203		KIT, repair	1
12	13S01		WASHER	8
13	30322A0505		KNOB	1
20	100S04		WASHER, bonded	5
21	122S04		ADAPTOR	1
22	119S08		ADAPTOR	4
25	11S03AA		SCREW, set	2
26	267S05		WASHER, flat	2
27	17S04		WASHER, spring	2

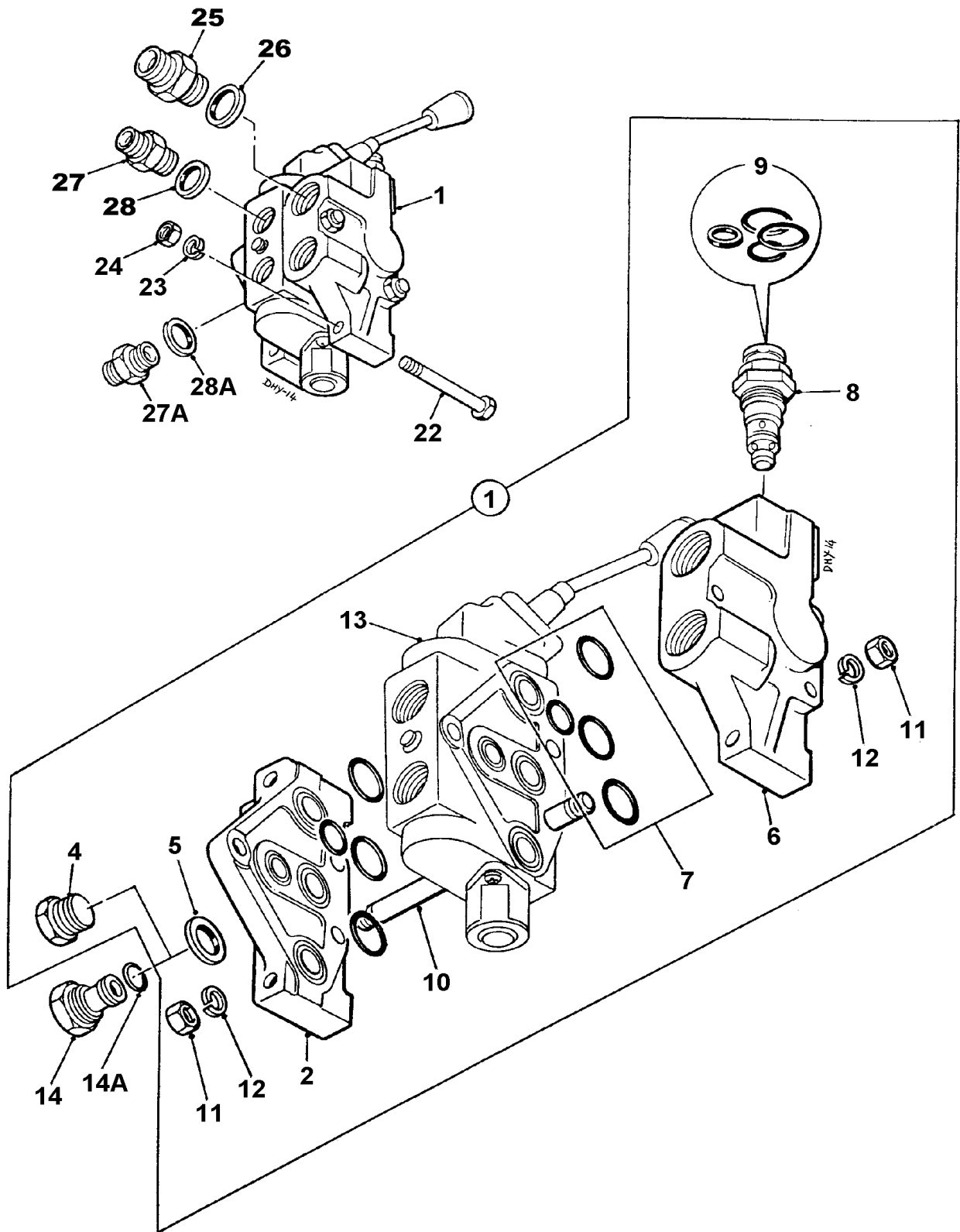

CONTROL VALVE, (sectional)**H - 2**

Item	Part no	Serial no	Description	Qty
1	V2000003	JAN 88 / 0965	CONTROL VALVE, assembly	1
2	V600017		COVER, inlet	1
4	-		"NOT USED"	
5	100S06		SEAL, bonded	1
6	V2003124		COVER, end	1
7	V600178		KIT, seals	1
8	V600022		VALVE, relief	1
9	V600023		KIT, seals	1
10	V600024		STUD	3
11	9S03		NUT	3
12	41S05		WASHER, spring	3
13	-		SECTION, valve (see page H - 3)	
14	451431029		ADAPTOR, carryover	1
14A	451431005		SEAL, 'O' ring	1
22	8S04J		BOLT	3
23	17S05		WASHER, spring	3
24	7S04		NUT	3
25	119S13		ADAPTOR, to check valve (illustrated)	1
25	119S10	/ 0749	ADAPTOR, to supply hose (not illustrated)	1
25	119S13	0750/	FITTING, adaptor (not illustrated)	1
26	100S06		SEAL, bonded	2
27	119S08		ADAPTOR	2
27A	119S08		ADAPTOR	1
28	100S04		SEAL, bonded	2
28A	100S04		SEAL, bonded	1

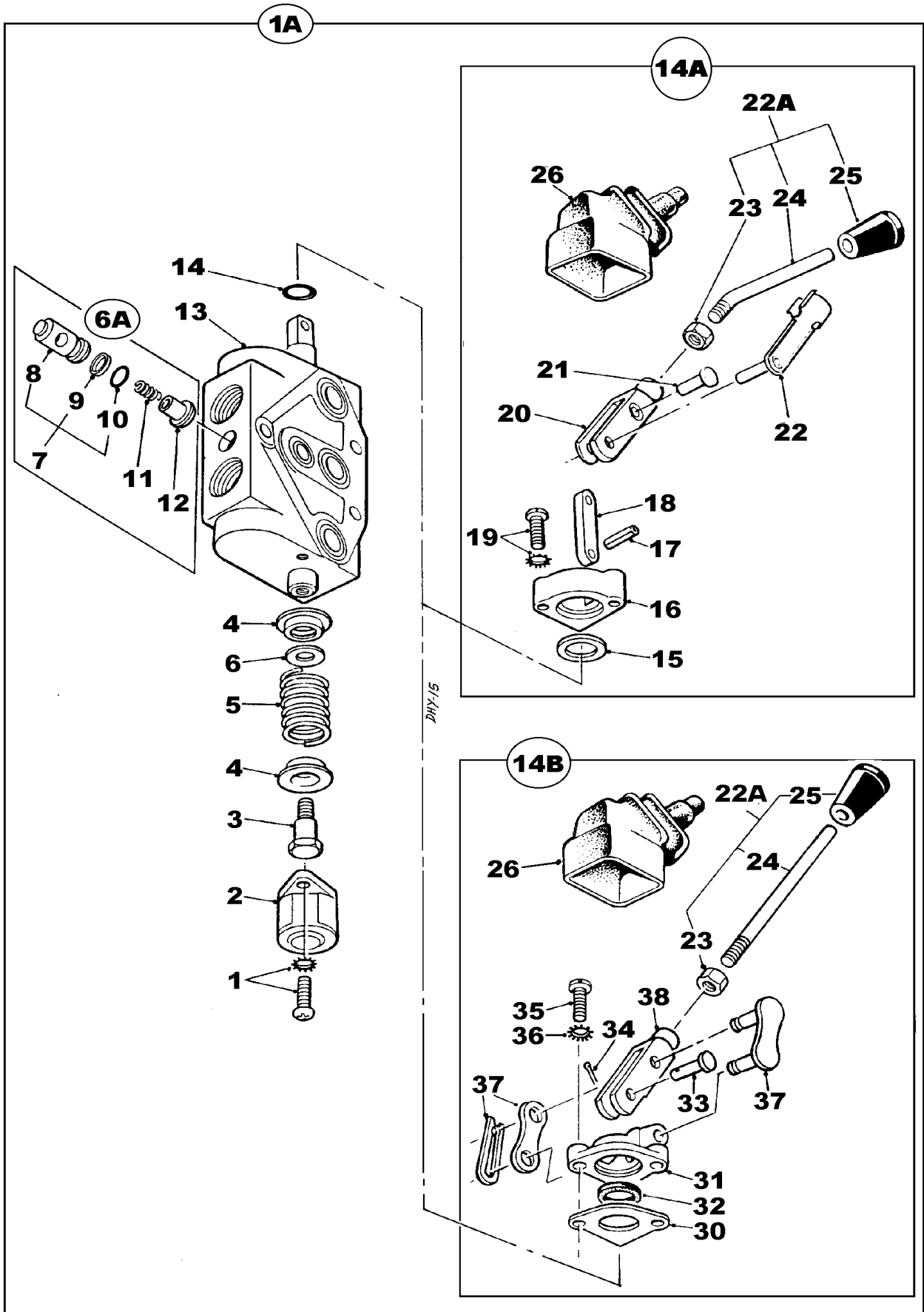

SECTION, control valve

H - 3

Item	Part no	Serial no	Description	Qty
1A	V600025	JAN-88/ 0965	SECTION, control valve c/w handle	
1	V600026	JAN-88/ 0965	SCREW, c/w washer	2
2	V600190	JAN-88/ 0965	CAP, end	1
3	V2003115	JAN-88/ 0965	SCREW, shoulder	1
4	V2003117	JAN-88/ 0965	SEAT, spring	2
5	V2003114	JAN-88/ 0965	SPRING	1
6	V600179	JAN-88/ 0965	SPACER	1
6A	V600180	JAN-88/ 0965	CHECK VALVE, assembly	1
7	V600181	JAN-88/ 0965	KIT, REPAIR, check valve	1
8	V2003118	JAN-88/ 0965	GUIDE, check valve	1
9	V600182	JAN-88/ 0965	RING, back up	1
10	V600183	JAN-88/ 0965	SEAL, 'O' ring	1
11	V2003119	JAN-88/ 0965	SPRING	1
12	V2003120	JAN-88/ 0965	POPPET	1
13	V600176	JAN-88/ 0965	BODY, c/w spool	1
14	V2003113	JAN-88/ 0965	SEAL, 'O' ring	2
14A	V600057	JAN-88/ Oct-93	LEVER, control valve, assembly	1
14B	V602166	OCT-93/ 0965	LEVER, control valve, assembly	1
15	V2003122	JAN-88/ Oct-93	SEAL, wiper	1
16	V600059	JAN-88/ Oct-93	BRACKET, handle	1
17	V600060	JAN-88/ Oct-93	PIN, roll	1
18	V600061	JAN-88/ Oct-93	LINK	1
19	V600062	JAN-88/ Oct-93	SCREW, c/w washer	2
20	V600063	JAN-88/ Oct-93	CLEVIS	1
21	V600064	JAN-88/ Oct-93	PIN	1
22	V600065	JAN-88/ Oct-93	PIN, clip	1
22A	V600159	JAN-88/ 0965	LEVER, assembly	1
23	V600066	JAN-88/ 0965	NUT	1
24	V602478	JAN-88/ 0965	HANDLE	1
25	V600068	JAN-88/ 0965	KNOB	1
26	V600069	JAN-88/ 0965	GAITER	1
30	V602448	OCT-93/ 0965	PLATE, seal	1
31	V602449	OCT-93/ 0965	BRACKET	1
32	V2003122	OCT-93/ 0965	SEAL, wiper	1
33	V602476	OCT-93/ 0965	PIN, clevis	1
34	V602475	OCT-93/ 0965	PIN, split	1
35	V602447	OCT-93/ 0965	SCREW	2
36	V602446	OCT-93/ 0965	WASHER	2
37	81S02	OCT-93/ 0965	LINK	1
38	V602477	OCT-93/ 0965	CLEVIS	1

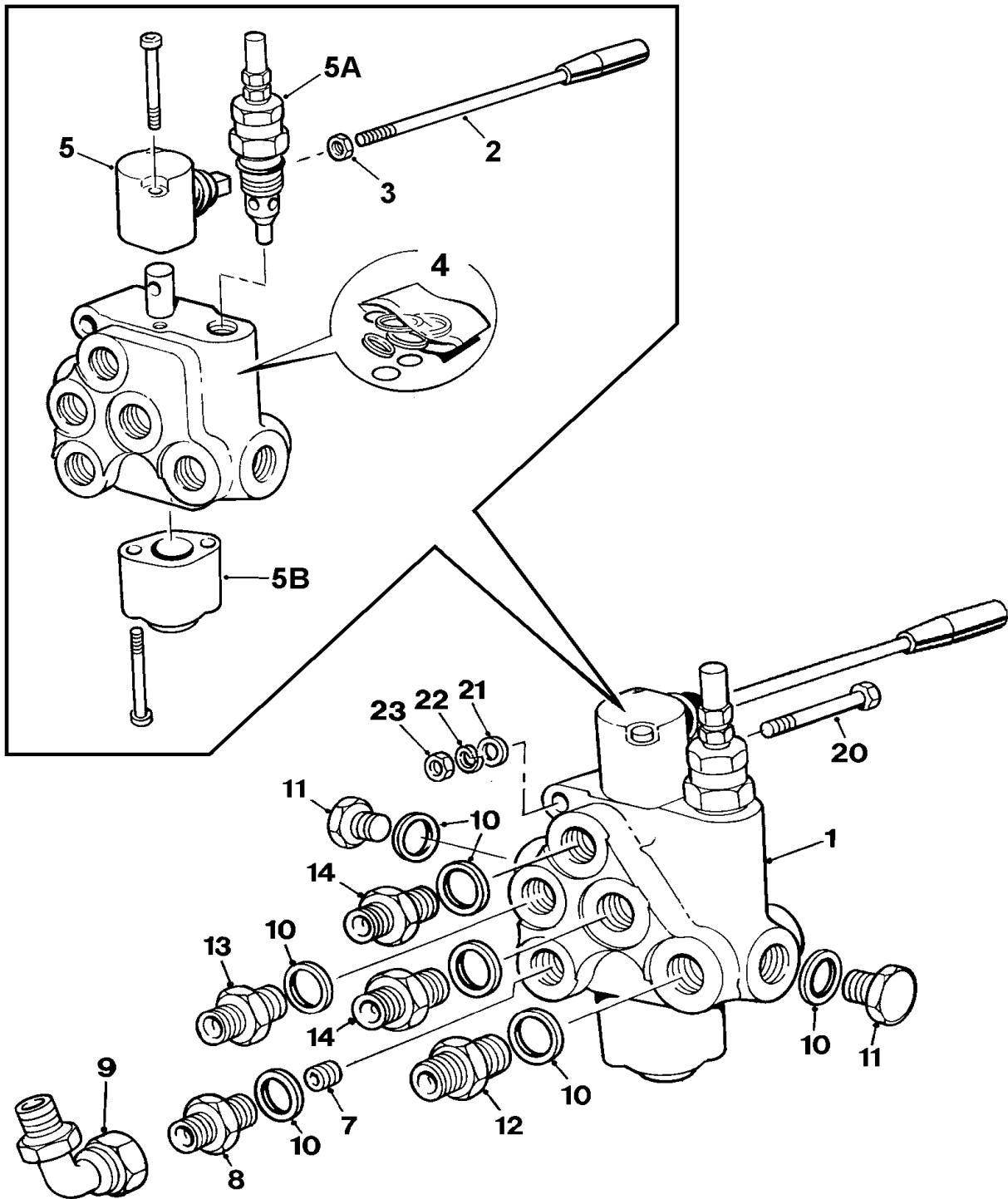

CONTROL VALVE, (monobloc)**H - 4**

Item	Part no	Serial no	Description	Qty
1	V2004606	0966 /	CONTROL VALVE	1
2	V602630		LEVER, knob & nut, assembly	1
3	7S04		NUT	1
4	V602629		KIT, control valve repair	AR
5	V603565		END CAP, lever	1
5A	V603605		VALVE, relief	1
5B	V603606		END CAP, spring base	1
7	V2004607		SCREW, socket head, H.P.C. <i>[Fitted inside valve]</i>	1
8	122S03		ADAPTOR, male/male	1
9	96S09		ELBOW, 90 ^o , male/female <i>[To steer valve hose]</i>	1
10	100S03		SEAL, bonded	7
11	127S03		PLUG	2
12	119S08		ADAPTOR, male/male <i>[Inlet from pump (RED)]</i>	1
13	119S08		ADAPTOR, male/male <i>[To tank (BLUE)]</i>	1
14	122S03		ADAPTOR, male/male <i>[Pressure to cylinder (GREEN)]</i>	2
20	8S03H		BOLT	2
21	267S05		WASHER, flat	2
22	17S04		WASHER, spring	2
23	7S03		NUT	2

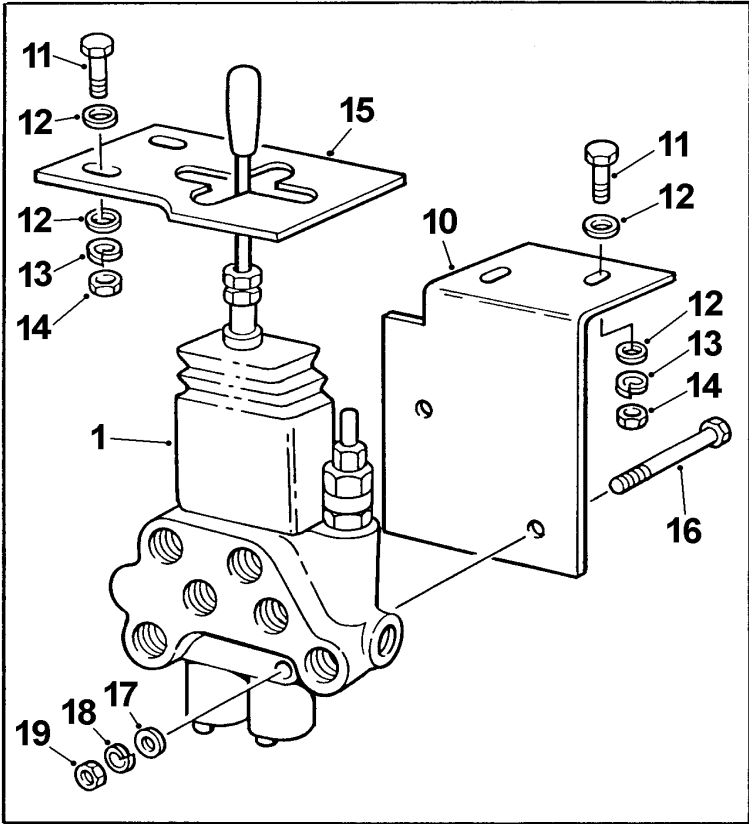

DHY-94

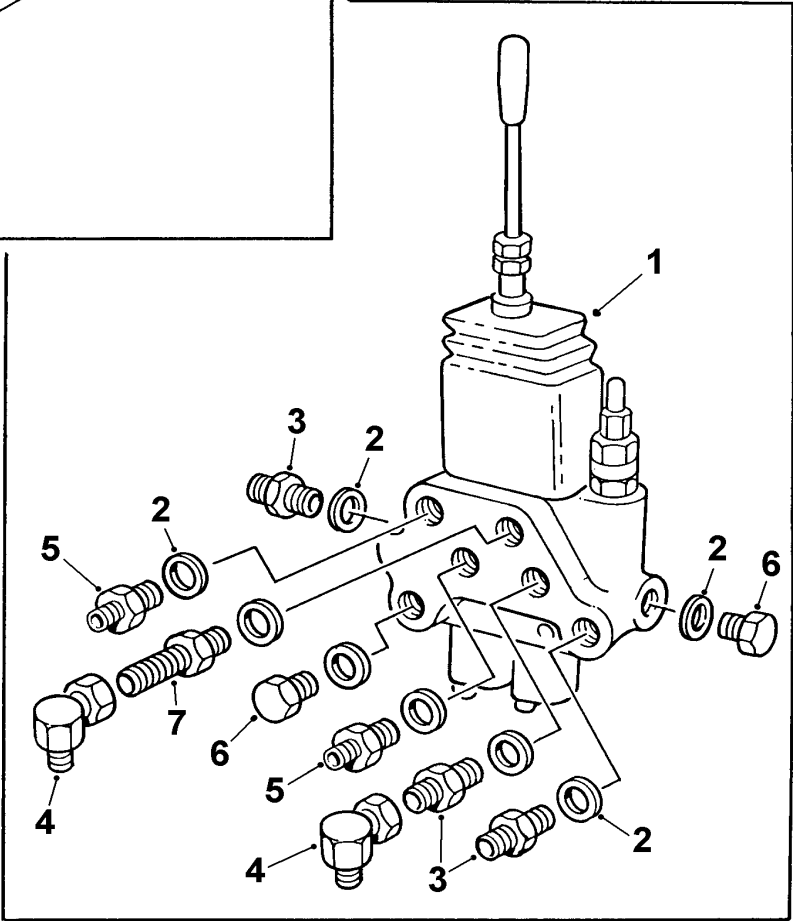

CONTROL VALVE, (Joystick)**H - 4A**

Item	Part no	Serial no	Description	Qty
1	V2004535		CONTROL VALVE, "Joystick"	1
2	100S03		SEAL, bonded	8
3	122S03		ADAPTOR, male/male	3
4	96S09		ELBOW, 90 ⁰ , male/female	4
5	119S03		ADAPTOR, male/male	2
6	127S03		PLUG	2
7	93S01		FITTING, bulkhead	1
10	V2004852		BRACKET, valve mounting	1
11	11S04C		SCREW, set	4
12	267S06		WASHER, flat	8
13	17S05		WASHER, spring	4
14	7S04		NUT	4
15	V2005387		GATE	1
16	11S03J		SCREW, set	2
17	267S05		WASHER, flat	2
18	17S04		WASHER, spring	2
19	7S03		NUT	2

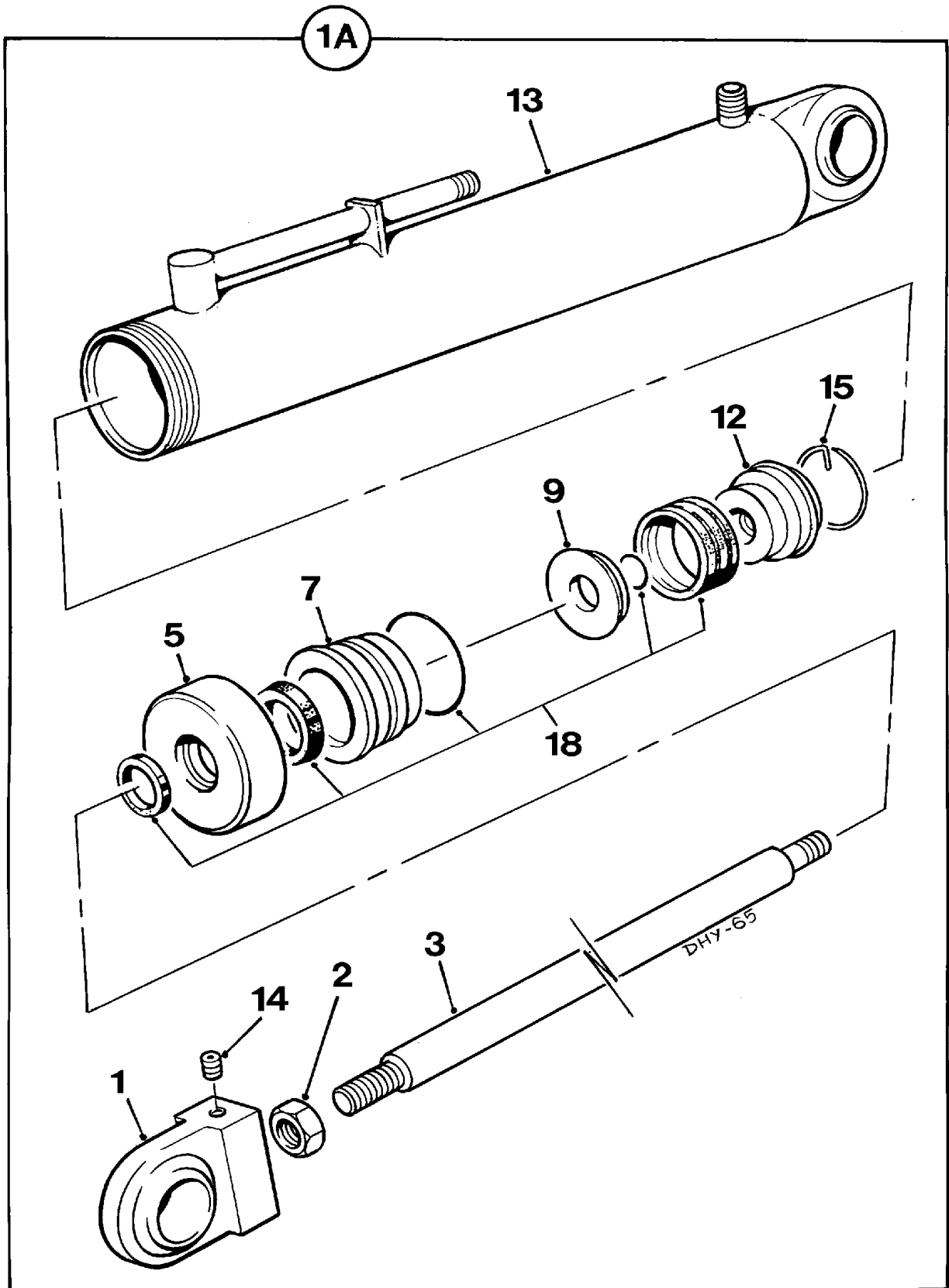

Item	Part no	Serial no	Description	Qty
1A	30121A03	/ 0981	RAM, steering, assembly	1
1	20100A02		HEAD	1
2	95S09		NUT, locking	1
3	30121A0302		ROD, ram	1
5	30121A0105		RETAINER	1
7	30121A0303		SLEEVE	1
9	30121A0109		WASHER, backing	1
12	30121A0112		PISTON	1
13	30121A0113		CYLINDER	1
14	30121A0114		SCREW, grub	1
15	30121A0115		RING, spring	1
18	CSE204		KIT, seals	1
...	V2003163		GRUBSCREW (where fitted to lock item 12)	1

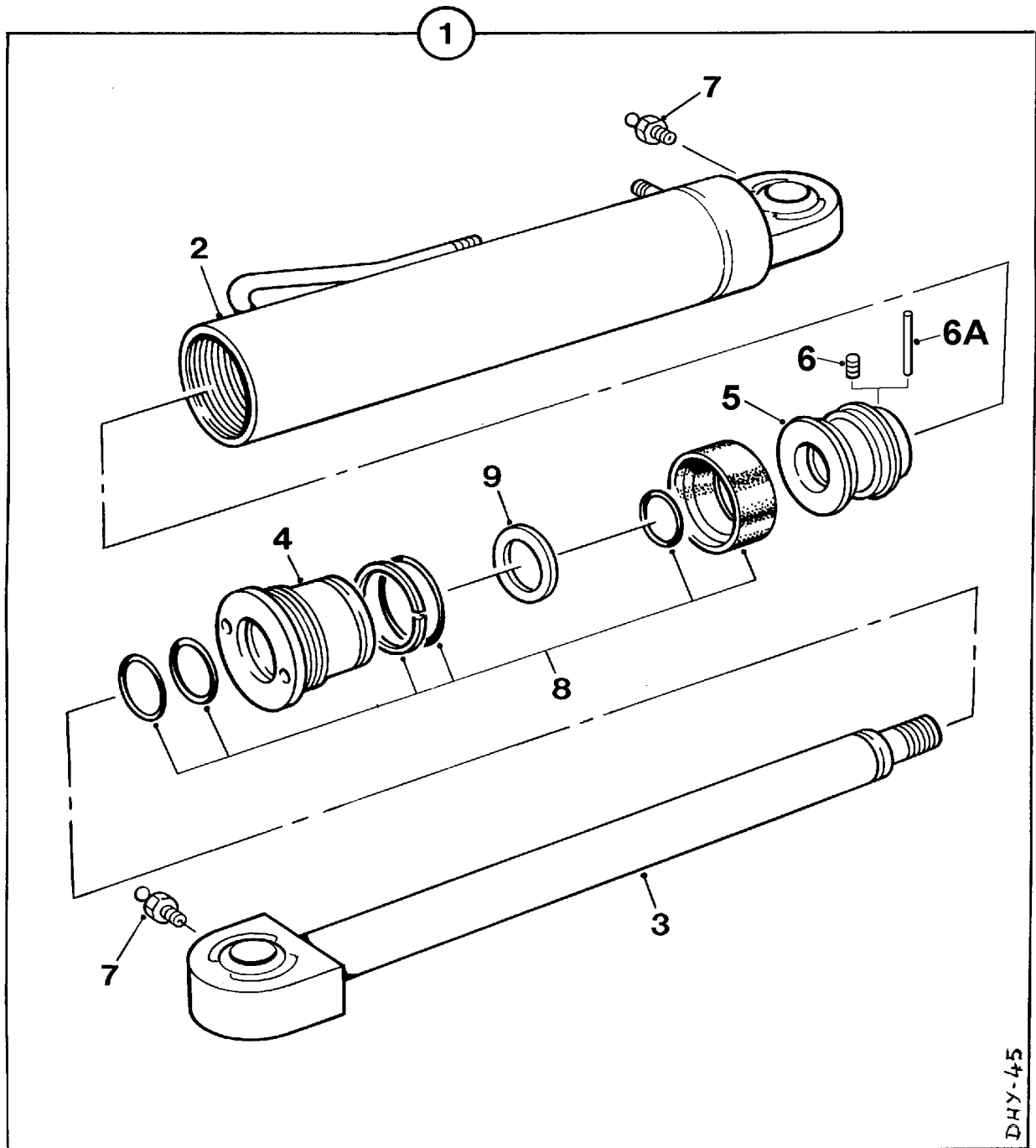

RAM, steering *from serial no. 0982***H - 5A**

Item	Part no	Serial no (date)	Description	Qty
1A	30121A04	0982 /	RAM, steering, assembly	1
2	30121A0405		CYLINDER	1
3	V2002566		ROD, piston	1
4	30121A0402		RETAINER	1
5	30121A0401		PISTON	1
6	57S04D2	/ Oct-99	SCREW, grub	1
6A	54S04N	Oct-99 /	PIN, roll	1
7	131S01		NIPPLE, grease	2
8	CSE204		KIT, seals	kit 1
9	30121A0403		RESTRICTOR	1

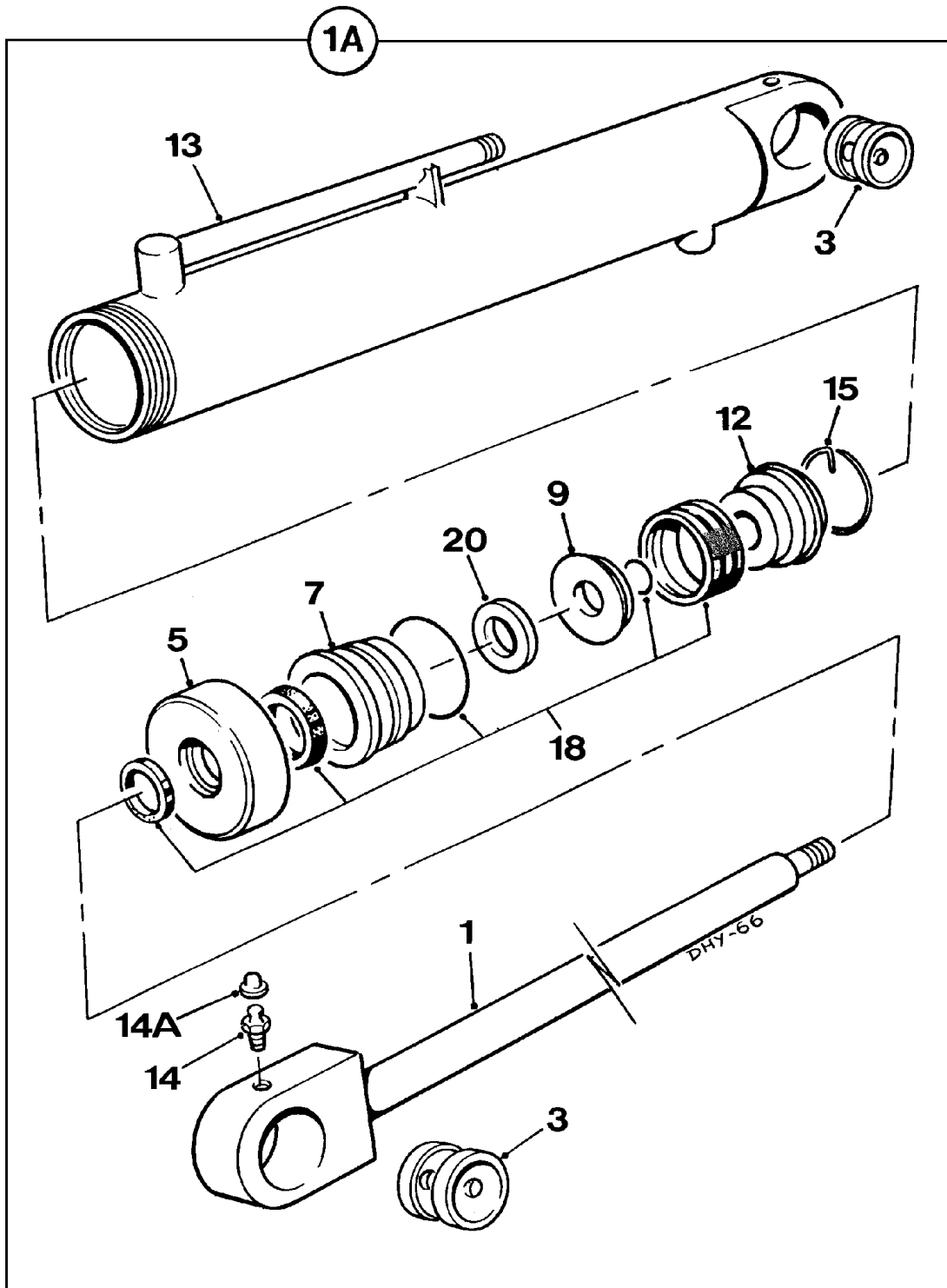
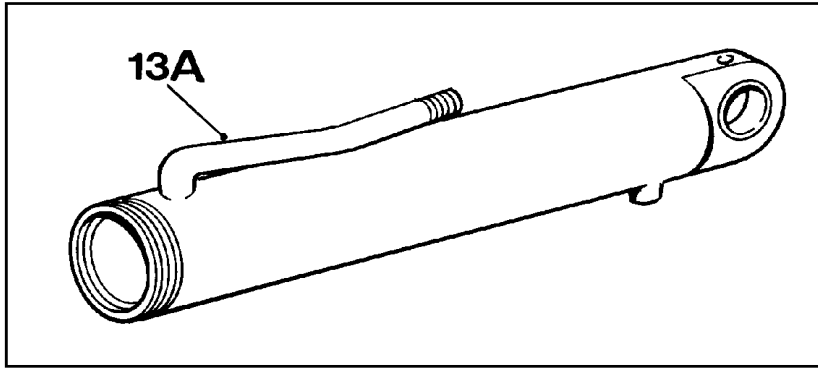

Item	Part no	Serial no	Description	Qty
1A	30161A08	/ 1033	RAM, tipping, assembly	2
1A	30161A09	/ 1033	RAM, tipping, assembly	2
1	30161A0802		ROD, ram	1
3	30161A0201		BUSH	2
5	30121A0105		CAP	1
7	30121A0107		SLEEVE	1
9	30121A0109		WASHER, backing	1
12	30121A0112		PISTON	1
13	30161A0801		CYLINDER, for ram 30161A08	1
13A	30161A0901		CYLINDER, for ram 30161A09	1
14	30162A0102		NIPPLE, grease	2
14A	176S01		CAP, grease nipple	2
15	30121A0115		RING, spring	1
18	CSE 204		KIT, seal	1
20	30161A0902		RESTRICTOR (<i>install as required</i>)	1

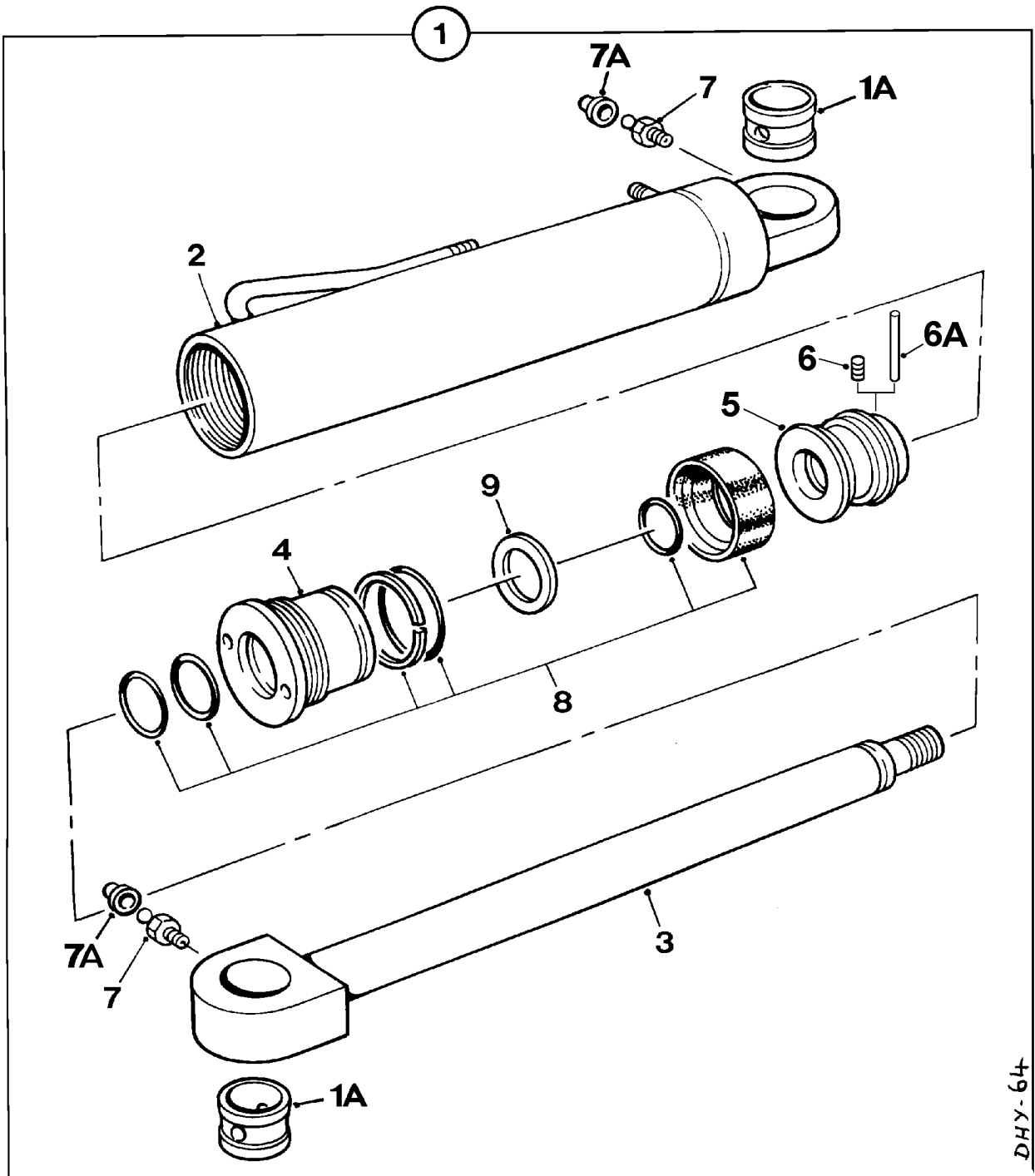

DHY-64

Item	Part no	Serial no (date)	Description	Qty
1	30161A10	1034 /	RAM, tipping, assembly	2
1A	30161A0803		BUSH, ram pivot	1
2	30161A1005		CYLINDER, ram	1
3	30161A1004		ROD, piston	1
4	30121A0402		RETAINER (one piece)	1
5	30121A0401		PISTON (one piece)	1
6	57S04D2	/ Oct-99	SCREW, grub	1
6A	54S04N	Oct-99 /	PIN, roll	1
7	131S01		NIPPLE, grease	2
7A	176S01		CAP, grease nipple	2
8	CSE204		KIT, seals	1
9	30161A0902		RESTRICTOR	1

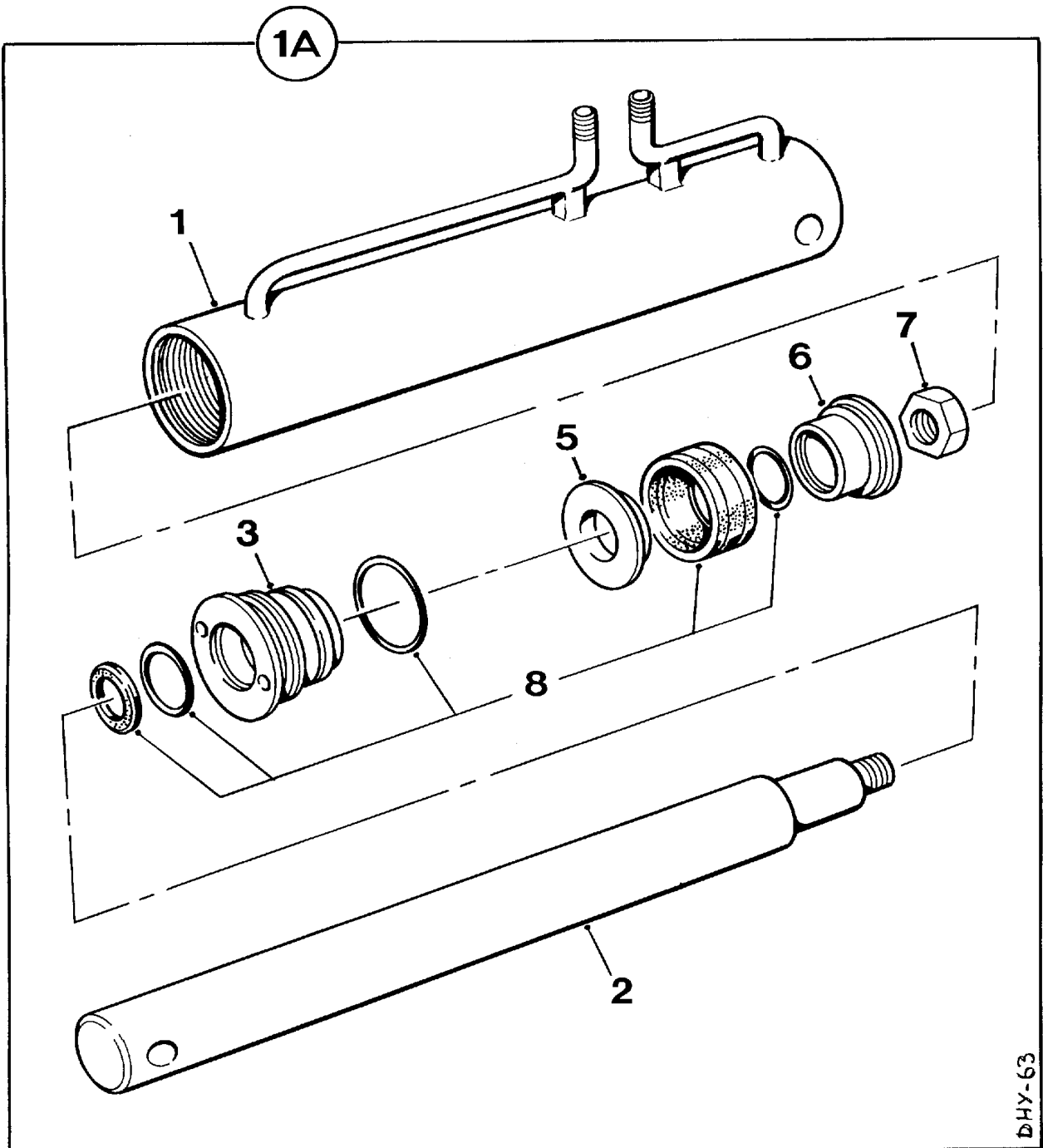

RAM, tipping, High discharge skip**H - 7**

Item	Part no	Serial no	Description	Qty
1A	30302A01		RAM, assembly	1
1	30302A0101		CYLINDER	1
2	30302A0102		ROD, piston	1
3	30302A0103		RETAINER	1
4	30302A0104		NUT, ring	1
5	30302A0105		PISTON, front	1
6	30302A0106		PISTON, rear	1
7	30302A0107		NUT, locking	1
8	30302A0108		KIT, seal	1

Not illustrated

.....	131S01		NIPPLE, grease	
.....	176S01		CAP, grease nipple	

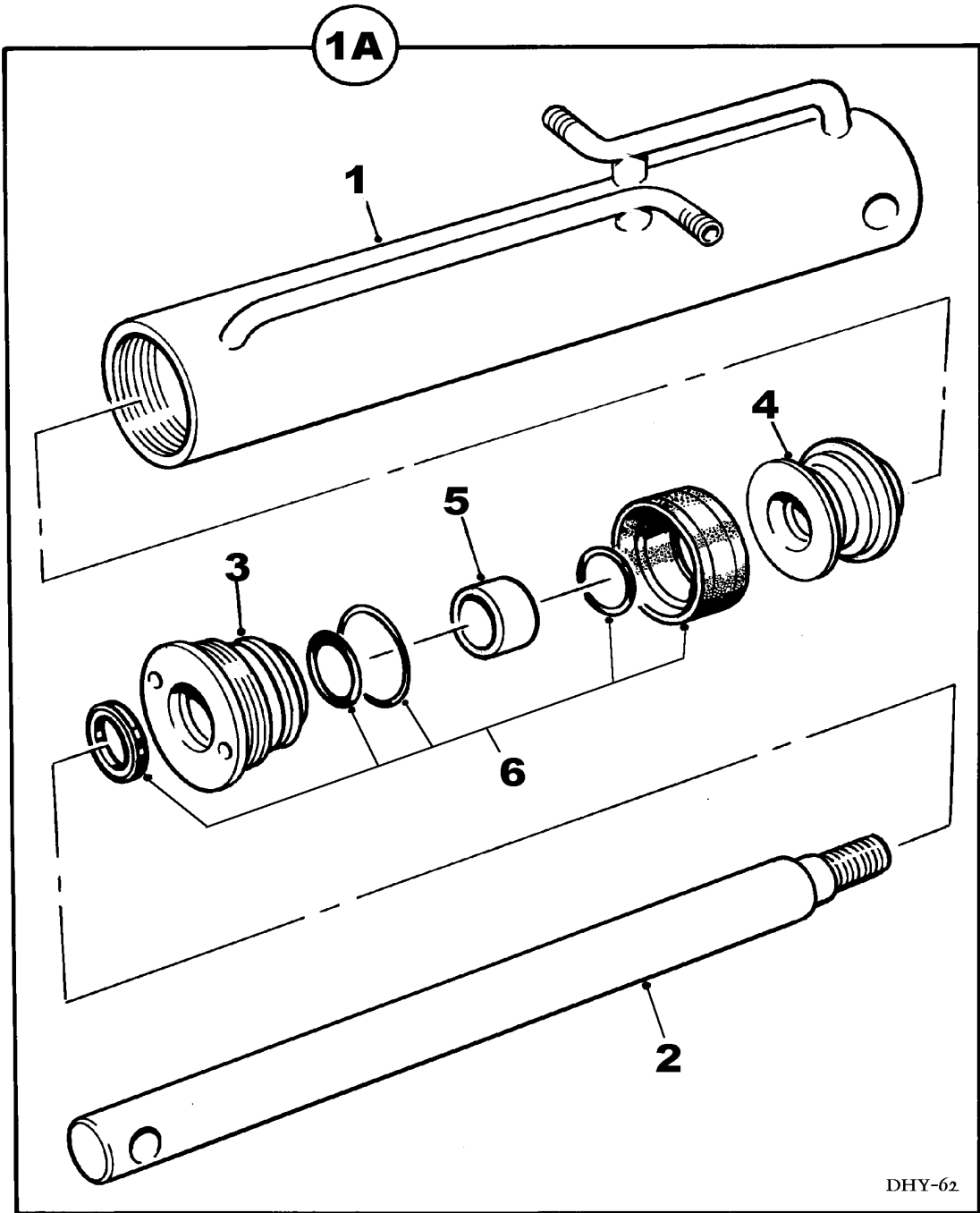

RAM, tipping, Manual rotating skip**H - 8**

Item	Part no	Serial no	Description	Qty
1A	30113A05		RAM, assembly	1
1	30113A0501		CYLINDER	1
2	30113A0402		ROD, piston	1
3	30113A0403		RETAINER	1
4	30113A0404		PISTON	1
5	30113A0405		RESTRICTOR	1
6	30113A0406		KIT, seals	1

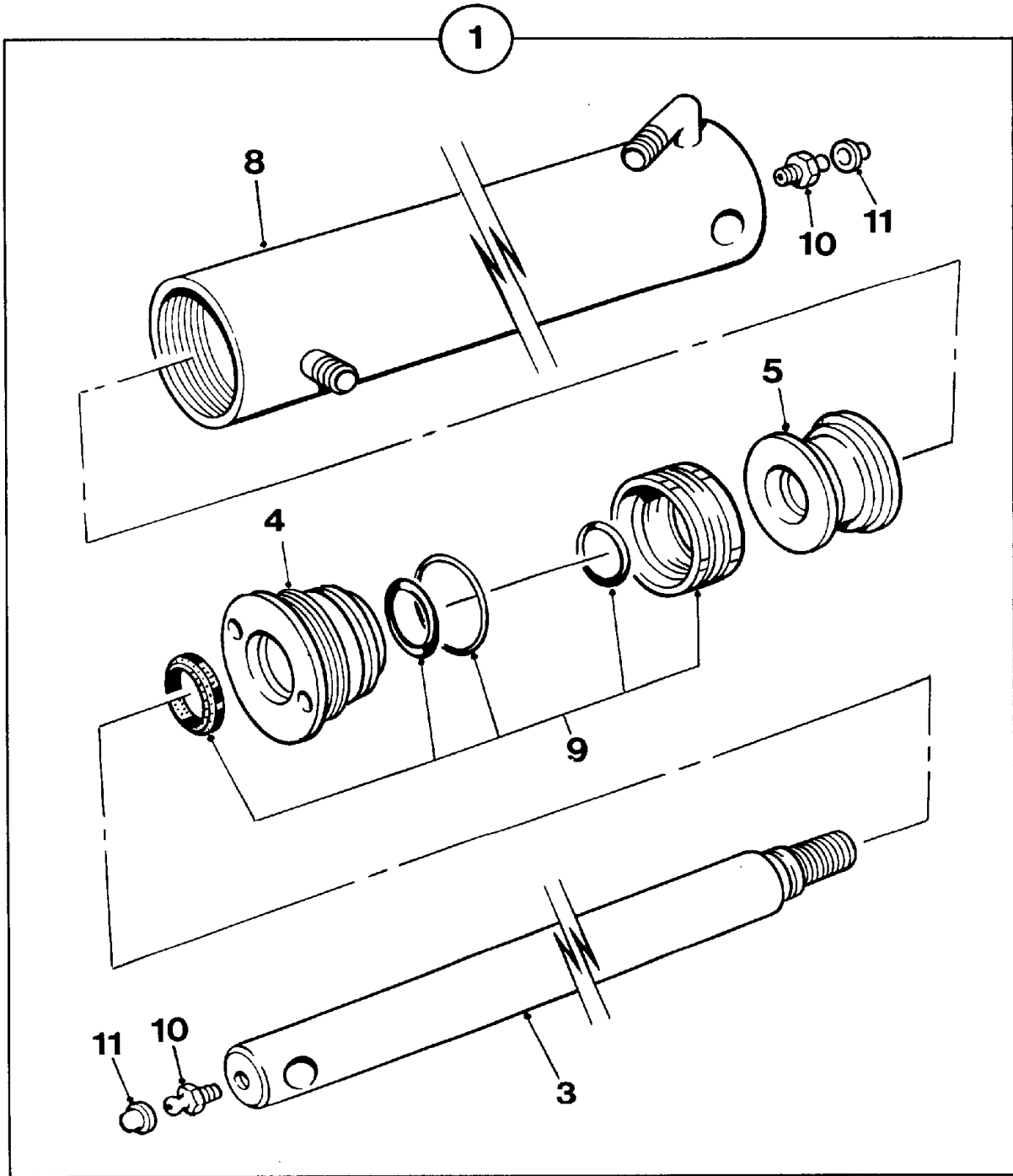

RAM, tipping, Hydraulic rotating skip**H - 9**

Item	Part no	Serial no	Description	Qty
1	30113A06		RAM, tipping, assembly	1
3	30113A0402		ROD, ram	1
4	30113A0403		RETAINER	1
5	30113A0404		PISTON	1
8	30113A0601		CYLINDER, ram	1
9	30113A0406		KIT, seals	1
10	131S01		NIPPLE, grease	2
11	176S01		CAP, grease nipple	2

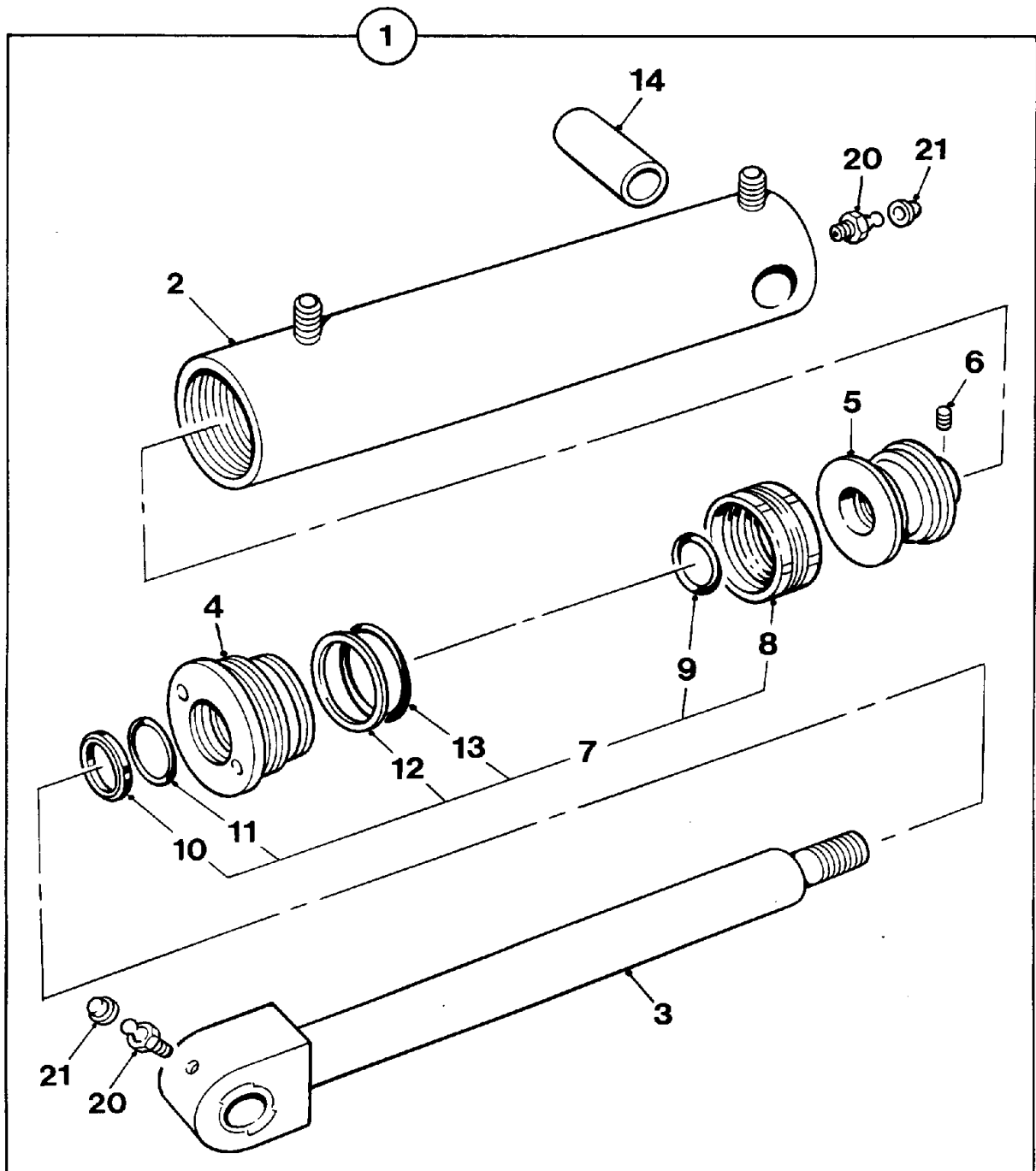

DHY-52

Item	Part no	Serial no	Description	Qty
1	30287A03		RAM, skip rotation, assembly	2
2	30287A0304		CYLINDER, ram	1
3	30287A0305		ROD, ram	1
4	30121A0402		CAP	1
5	30121A0401		PISTON	1
6	57S04D2		SCREW, grub	1
7	CSE204		KIT, seals	1
8	—		SEAL, piston	1
9	—		"O" RING	1
10	—		SEAL, wiper	1
11	—		SEAL	1
12	—		BACKING RING	1
13	—		"O" RING	1
14	V2004682		BUSH	1
20	131S01		NIPPLE, grease	2
21	176S01		CAP, grease nipple,	2

Decals & Plates

DECALS & PLATES

J - 1 to J - 4

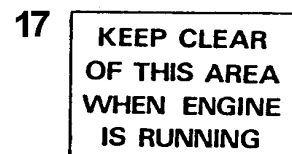
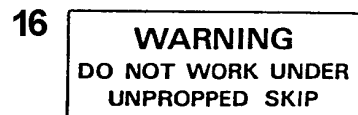
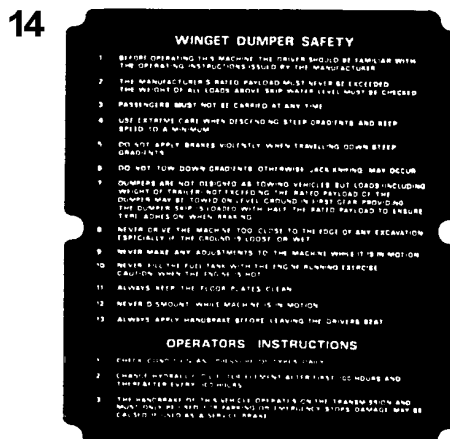
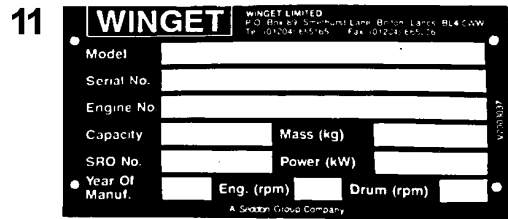
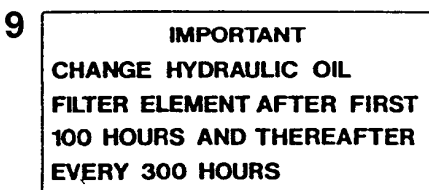
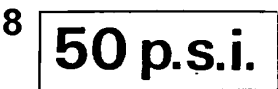
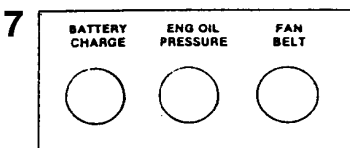
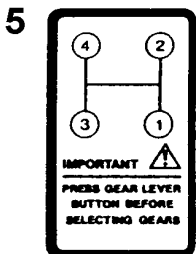
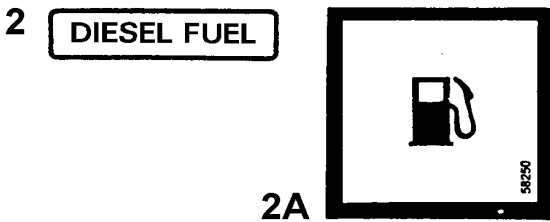
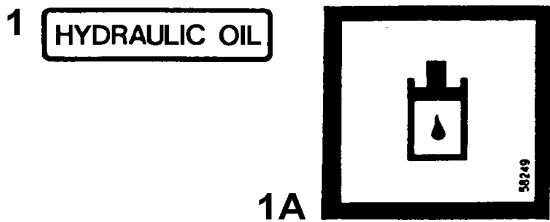

DECALS & PLATES

J - 1

Item	Part no	Serial no	Description	Qty
.....	V601769		KIT, decals, 4B2000 <i>The kit contains all current decals required for one machine.</i>	
1		HYDRAULIC OIL, <i>OBSOLETE: use 1A</i>	
1A	V2003100		HYDRAULIC OIL	
2		DIESEL FUEL, <i>OBSOLETE: use 2A</i>	
2A	V2003101		DIESEL FUEL	
3	V2003038		STRIPE, bodywork, 2 colour	
4	V2003039		WINGET, logo	
5	V2003157		GEAR POSITIONS	
7	V2000348		WARNING LIGHTS	
8	10166A02		50 psi tyre pressure	
9	10215A03		CHANGE HYDRAULIC OIL FILTER	
10	10284A01		DUMP / RETURN	
11	V2003037		PLATE, serial	
.....	101S05D		RIVET (for serial plate)	
12	10536A02		NON FREE-RUNNING LOADS	
14	20132A03		PLATE, safety instructions	
15	4602331		NEGATIVE EARTH	
16	DM157		SKIP WARNING	
17	DM198		KEEP CLEAR WARNING (<i>obsolete see item 20 on page J-3</i>)	
18	FSE357		ENGINE STOP	

3

RECOMMENDED LUBRICATING OILS					
COMPONENT	GRADE	SAE GRADE	SAE GRADE	SAE GRADE	HYDRAULIC SYSTEM
ENGINE	SAE 15W-40	SAE 15W-40	SAE 15W-40	SAE 15W-40	SAE 15W-40
TRANSMISSION	SAE 80W-90	SAE 80W-90	SAE 80W-90	SAE 80W-90	SAE 80W-90
DIFFERENTIAL	SAE 80W-90	SAE 80W-90	SAE 80W-90	SAE 80W-90	SAE 80W-90
STEERING	SAE 80W-90	SAE 80W-90	SAE 80W-90	SAE 80W-90	SAE 80W-90
AXLES	SAE 80W-90	SAE 80W-90	SAE 80W-90	SAE 80W-90	SAE 80W-90
WHEELS	SAE 80W-90	SAE 80W-90	SAE 80W-90	SAE 80W-90	SAE 80W-90
HYDRAULIC SYSTEM	SAE 46	SAE 46	SAE 46	SAE 46	SAE 46

14 THIS HANDBRAKE OPERATES ON THE TRANSMISSION AND MUST ONLY BE USED FOR PARKING OR EMERGENCY STOPS. DAMAGE MAY BE CAUSED IF USED AS A SERVICE BRAKE

15 maximum payload 2500 kgs

16 maximum payload 3000 kgs

6 40 p.s.i.



7 WARNING! TIGHTEN WHEEL NUTS DAILY

8 4B2000

9 35 p.s.i.

10 maximum payload 2000 kgs

11 maximum payload 5000 kgs

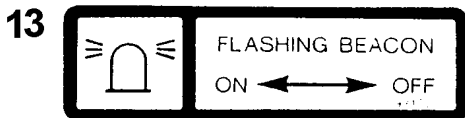

DECALS & PLATES**J - 2**

Item	Part no	Serial no	Description	Qty
3	DM196		LUBRICATION OIL	
6	10540A01		40 psi tyre pressure	
7	V2003142		WARNING - TIGHTEN WHEEL NUTS	
8	V2003154		4B2000	
9	10540A02		35 psi tyre pressure	
10	10540A13		MAXIMUM PAYLOAD 2000kgs	
13	V2003143		FLASHING BEACON	
14	DM106		HANDBRAKE WARNING	
15	10541A20		MAXIMUM PAYLOAD 2500kgs	
16	10541A22		MAXIMUM PAYLOAD 3000kgs	
17	V2003598		BRITISH MADE	

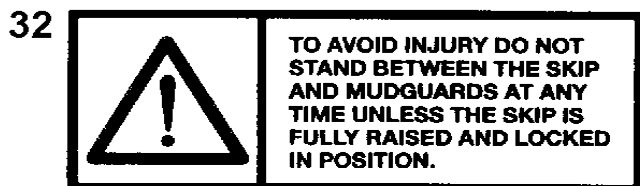
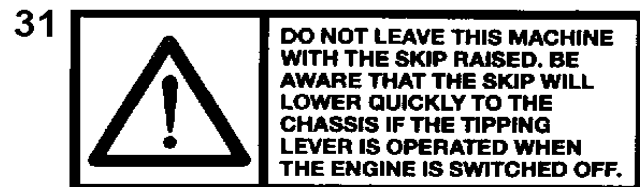
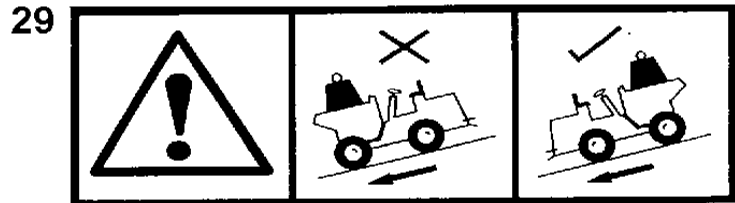
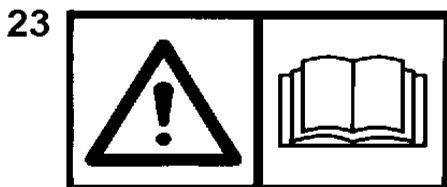
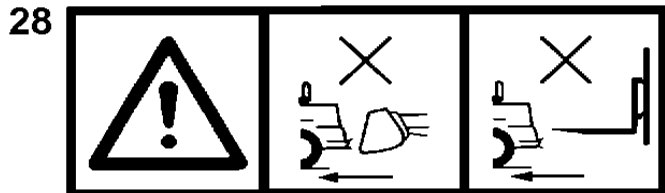
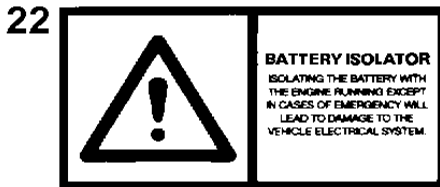
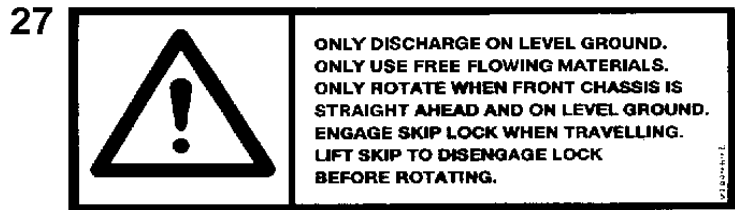
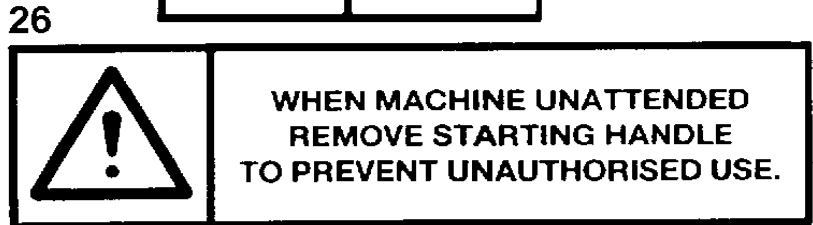
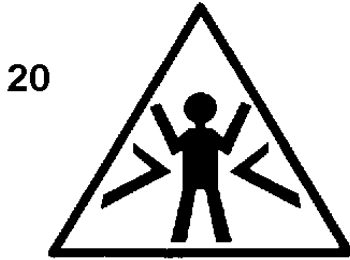
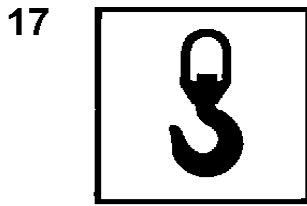

DECALS & PLATES

J - 3

Item	Part no	Serial no	Description	Qty
17	V2003665		SLING POINTS	
20	V2004191		CRUSH ZONE	
21	V2004307		ELECTRICAL HAZARD	
22	V2004227		BATTERY ISOLATOR	
23	V2004229		OPERATOR'S HANDBOOK	
24	V2004235		NEGATIVE EARTH	
25	V2004282		HOT SURFACE	
26	V2004288		STARTING HANDLE	
27	V2004642		ROTATING HAZARD	
28	V2004245		NO BUCKETS	
29	V2004450		GRADIENTS	
30	V2004744		EYE PROTECTION	
31	V2004798		SKIP RAISED	
32	V2004799		TO AVOID INJURY	

1

<h3><u>SAFETY WARNING</u></h3> <ol style="list-style-type: none">1. Before starting this machine, the operator should be familiar with the operating instructions issued by the manufacturer.2. The manufacturer's rated capacity must never be exceeded.3. Before carrying out any maintenance, servicing, or greasing, always ensure that the engine has been switched off. Never work on a machine while it is running. <p style="text-align: right;"><small>W504694600</small></p>
--

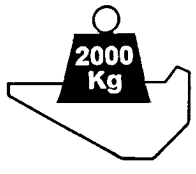

2

	
---	---

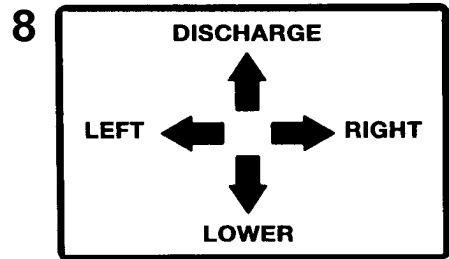

3

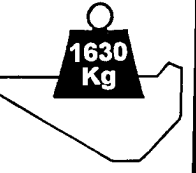
	
--	---

4

	TIGHTEN SLEW RING BOLTS EVERY WEEK
---	---

5

	ROPS/FOPS STRUCTURE NOT TO BE REPAIRED, IF DAMAGED A REPLACEMENT STRUCTURE MUST BE INSTALLED. ANY UNAUTHORISED MODIFICATION WILL VOID CERTIFICATION AND RESULT IN INJURY.
---	--

6

	TO AVOID DAMAGE TO THE TRANSMISSION AND DRIVE TRAIN BRING MACHINE TO A STANDSTILL BEFORE CHANGING FORWARD OR REVERSE DIRECTION.
---	--

DECALS & PLATES

J - 4

Item	Part no	Serial no	Description	Qty
1	504694600		SAFETY WARNING	
2	V2004608		PAYLOAD 2000KG <i>Standard & high discharge skips, also rotating skips when the dumper is fitted with Newage 212/215 axles.</i>	
3	V2004790		PAYLOAD 1630KG <i>Manual rotating skips when the dumper is fitted with Newage 175/200 axles.</i>	
4	V2004680		TIGHTEN SLEW RING BOLTS	
5	V2004754		ROPS/FOPS STRUCTURE	
6	V2004748		TRANSMISSION	
7	V2004137		EAR PROTECTION	
8	V2004643		DUMP SLEW / RETURN	

CALIFORNIA

Proposition 65 Warning

Diesel engine exhaust and some of its constituents are known to the State of California to cause cancer, birth defects, and other reproductive harm