

200T MIXER

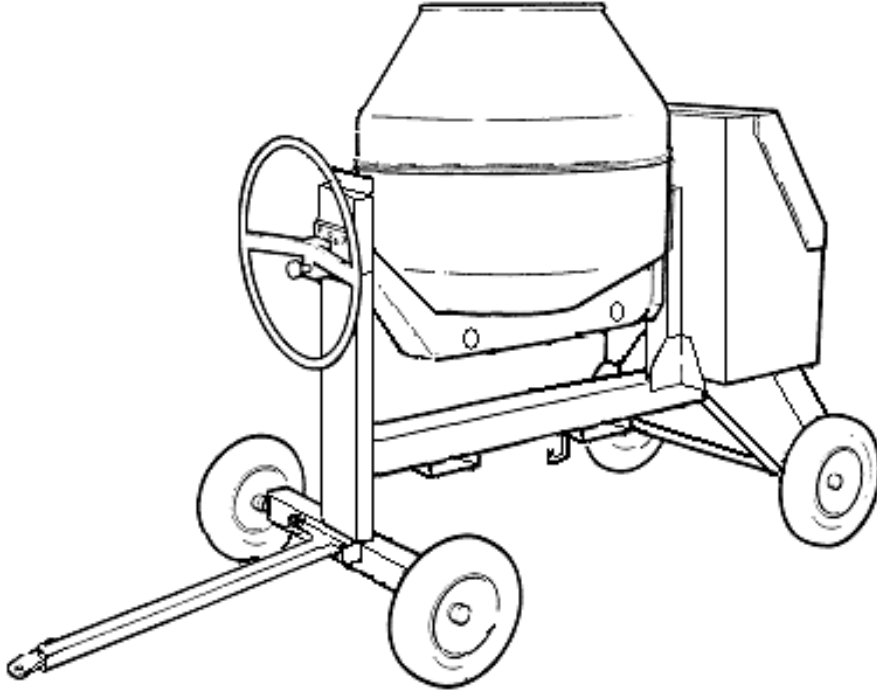

OPERATORS HANDBOOK & PARTS

Manual V603683 August 2023

From Machine Serial No T200XF1333

WINGET

WINGET LIMITED, P.O. Box 41, Edgefold Industrial Estate, Plodder Lane, Bolton, BL4 0LR, England
Tel: +44 (0) 1204 854650
parts@winget.co.uk
service@winget.co.uk
www.winget.co.uk

CONTENTS

Section	Page	Section	Page
INTRODUCTION		TECHNICAL INFORMATION	
Introduction	II	Lubricants	4.1
Warranty	III	Noise levels	4.1
Safe Working	1.1	Drum speed	4.1
Decals	1.3	Mixer drum sealant	4.1
Lashing down & lifting points	1.6	Engines	4.1
OPERATION		Dimensions	4.2
Installation	2.1	Yanmar L48 ARE-SE/L48N5SJ1 /L48V5V key start wiring	4.3
Lister-Petter LV1-910 engines	2.2	PARTS	
Yanmar L48 ARE-SE/L48N5SJ1 /L48V5V engines	2.4	Illustrations of all mixer components	
Mixer drum positions	2.7		
Mixing	2.7		
End of work procedures	2.8		
SERVICING			
Service schedule	3.1		
Greasing & lubrication	3.2		
Drum drive	3.2		
Bolt torques	3.3		
Engines:			
<i>(Lister-Petter only. For Yanmar engines, see separate Operator's Manual)</i>			
Air cleaner	3.3		
Engine lubrication oil	3.4		
Fuel filter & priming the fuel system	3.5		
Battery	3.6		
Mixer drum assembly	3.7		
Mixer drum drive overhaul	3.9		

The Handbook

The contents of this Handbook, although correct at the time of publication may be subject to alteration by the Manufacturers without notice. Winget Limited operate a policy of continuous product development. Therefore, some illustrations or text within this publication may differ from your machine.

WARNING



The operator must read all the Handbook and fully understand its contents before attempting to operate the machine.

THE HANDBOOK MUST NOT BE REMOVED FROM THE MACHINE.

The Handbook must be kept clean and in good condition. Additional copies of the Handbook can be obtained from your Distributor. These are the original instructions in the English Language issued by Winget Limited to comply with the requirements of Directive 2006/42/EC.

The contents of this Operator's Handbook are designed as a guide to the machine's controls, operation, working capacities and maintenance. It is **not** a training manual.

Only trained operators should use this machine. Contact the C.I.T.B. or equivalent body for advice on training.

WARNING



In this Handbook are **WARNING** notes. They are preceded by this symbol:

WARNING



These notes are used to indicate the procedure being described in the Handbook must be followed to avoid serious injury or death to yourself or to others, or damage to the machine.

The warnings are also used to protect the machine from unsafe servicing practices.

Pay particular attention to the warnings given in the Handbook.

If you have any doubts about any aspect of the machine's capability or servicing procedures, you must consult the manufacturer.

Warranty terms & conditions

The Manufacturer assures you that if any part of the machine becomes defective due to faulty manufacture or materials within 12 months from the date of purchase, the part will be repaired or replaced under warranty free of charge by any authorised Winget Distributor. Warranty repairs **must** be carried out by Winget Distributors.

This Warranty is given to the first owner and may be transferred to subsequent owners for the balance of the Warranty period.

The Manufacturer's liability only extends to the costs of repair or replacement of the faulty parts and necessary labour charges involved in the repairs. The Company accepts no liability for any consequential loss, damage or injury, resulting directly or indirectly from any defect in the goods.

Items not covered by Warranty and considered to be the customer's responsibility include normal maintenance services; replacement of service items and consumables; replacement required due to abuse, accident, misuse or improper operation; replacement of wearable items e.g. pins, bushes, brake linings, clutch linings etc.

The Warranty will not apply where the equipment is modified, converted, or used for purposes other than those for which it was designed, unless clearance for the modifications etc. have been granted by the Manufacturer, in writing.

The Pre-Delivery Inspection and Warranty Registration Document must be completed correctly and returned to the Manufacturer within 7 days of sale date. Failure to do so may result in the claim being subsequently rejected.

Tyres and tubes are not covered by Warranty, but are covered by the tyre manufacturer's own warranty system which provides against defects in material or workmanship. Engines are covered separately by the engine manufacturers, and engine warranty repairs must be handled by the relevant engine manufacturers' distributors.

No claim will be considered if other than genuine Winget Limited parts, which must be obtained from Winget Limited via an authorised Distributor, are used to effect a repair, or if lubricants other than those recommended by Winget Limited are used.

The equipment must be serviced in accordance with the service schedules laid down by Winget Limited. Evidence that these have been complied with may be required before Warranty Claims are reimbursed.

The Manufacturer's policy is one of continuous improvement. Winget Limited reserve the right to change specifications without notice. No responsibility will be accepted for discrepancies which may occur between specification of machines and the descriptions contained in publications.

Safety is the responsibility of the persons working with this machine. Think “safety” at all times. ***Read and remember the contents of this Handbook.***

MACHINE MODIFICATION

WARNING Any modifications to the machine will affect its working parameters and safety factors. Refer to the Manufacturers before fitting any non-standard equipment or parts.



The manufacturers accept no responsibility for any modifications made after the machine has left the factory, unless previously agreed by the Manufacturers in writing. The Manufacturers will accept no liability for damage to property, personnel or the machine if failure is brought about due to such modifications, or fitment of spurious parts.

OPERATION

WARNING Only trained operators should use this machine.



Always be aware of local and national regulations governing the use of the machine.

Always ensure that all guards are in position and correctly fitted.

Only authorised persons should be allowed to operate the mixer, or be in the immediate area.

Never add fuel or lubricant to the machine while it is running.

Keep the area around the machine clear of obstructions which could cause persons to fall onto moving parts.

Keep the body and clothing clear of all moving and hot parts.

Always ensure that during operation the mixer is standing on **stable and level ground and that the wheels are chocked or the handbrake is applied.**

Keep the engine housing lid closed when the engine is running.

Always wear PPE (personal protective equipment) when operating this equipment, i.e. gloves, eye protection, ear protection.

The lifting points are designed to be used to lift the equipment for loading or unloading purposes only. Never use the lifting eyes or lashing down points in an attempt to free a machine which may be trapped in mortar or concrete.

ENGINE**WARNING**

Starting any diesel engine can be dangerous in the hands of inexperienced people. Operators must be instructed in the correct procedures before attempting to start any engine.

Always obtain advice before mixing oils; some oils are not compatible. If in doubt, drain and refill.

The materials used in the manufacture and treatment of some filters and elements may cause irritation or discomfort if they come into contact with the eyes or mouth and they may give off toxic gases if they are burnt.

Engine lifting eyes must not be used to lift the complete machine.

Ether based cold start aids in aerosol cans must not be used under any circumstances.

EXHAUST GASES CONTAIN CARBON MONOXIDE WHICH IS A COLOURLESS, ODOURLESS AND POISONOUS GAS THAT CAN CAUSE UNCONSCIOUSNESS AND DEATH.

ELECTRICAL SYSTEMS**WARNING**

Starting engines that are fitted with charge windings/alternators which have been disconnected from the battery may cause irreparable damage.

The following points must be strictly observed when charge windings are fitted otherwise serious damage can be done.

Never remove any electrical cable while the battery is connected in the circuit.

Only disconnect the battery with the engine stopped and all switches in the OFF position.

Always ensure that cables are fitted to their correct terminals. A short circuit or reversal of polarity will ruin diodes and transistors.

Never connect a battery into the system without checking that the voltage and polarity are correct.

Never flash any connection to check the current flow.

Never experiment with any adjustments or repairs to the system.

The battery and charge windings/alternators must be disconnected before commencing any electric welding when a pole strap is directly or indirectly connected to the engine.

BATTERIES CONTAIN SULPHURIC ACID, WHICH CAN CAUSE SEVERE BURNS AND PRODUCE EXPLOSIVE GASES. If the acid has been splashed on the skin, eyes or clothes flush with copious amounts of fresh water and seek immediate medical aid.

SERVICING & MAINTENANCE**WARNING**

Never allow unqualified personnel to attempt to remove or replace any part of the machine, or anyone to remove large or heavy components without adequate lifting equipment.

Before maintenance work is begun, ensure that the engine is stopped and the starting handle or start key removed to prevent un-authorized start up.

Always conform to service schedules except when an emergency calls for immediate action, or adverse conditions necessitate more frequent servicing.

Always report any defect at once, before an accident or consequential damage can occur.

On completion of maintenance, check that the machine functions correctly, and that all guards are correctly fitted.

Disposal of waste oil. Dispose of waste oil into waste oil storage tanks. If storage tanks are not available, consult your Distributor or local authority for addresses of local designated disposal points. It is illegal to dispose of waste oil into drains or water courses, or to bury it.

DECALS

Ensure that all warning decals fitted to the mixer are legible. If any should become detached, they must be replaced immediately.

Descriptions of the pictorial decals are as follows:

Fuel tank filling point.



Read Operators Handbook, or Operators Handbook storage place.

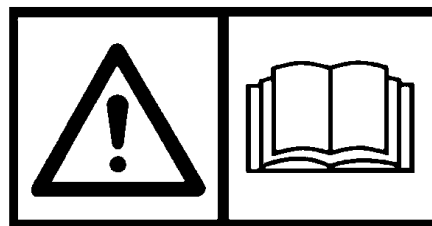

Attach lifting hooks to this eye.



The battery negative terminal is connected to earth.

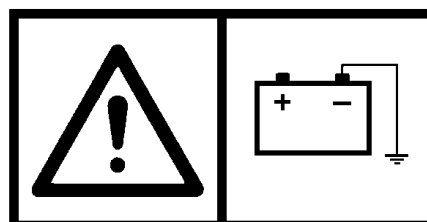

Remove starting handle.



Battery isolator.

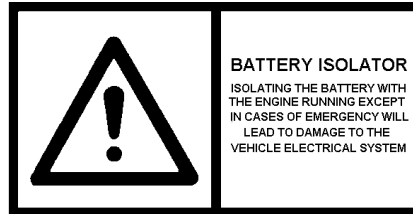

Beware of electrical hazards.

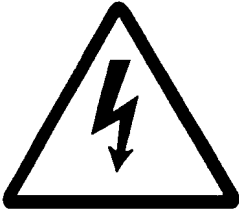

Wear ear protection.



Engine stop.

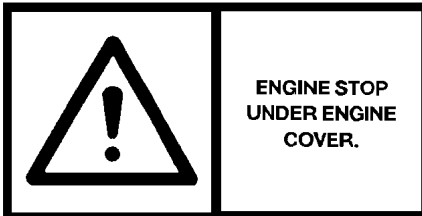

Wear eye protection.



Keep clear of chain drives.

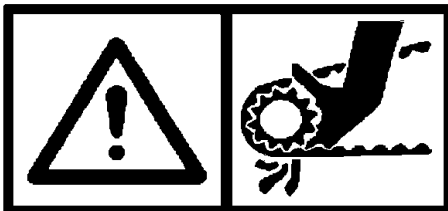

These surfaces may be hot.



Conforms to EC standards.



Keep hands clear of drum.

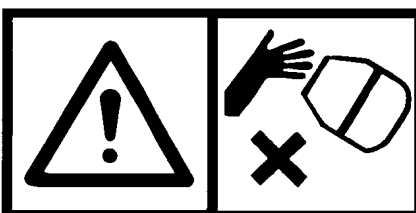

ISO 8999 safety symbols used with Lister/Petter engines



Read the handbook

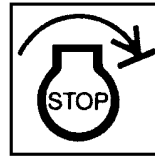

Stop control (on engine)

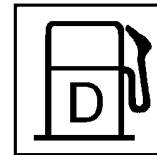

Diesel fuel fill



Engine oil fill

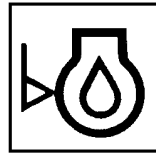

Engine oil level

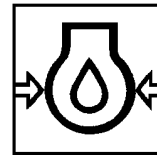

Engine oil pressure

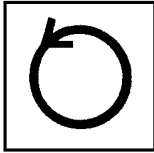

Anti-clockwise rotation

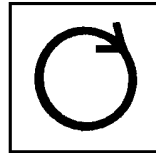

Clockwise rotation



Lifting eye - engine only

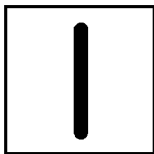

On

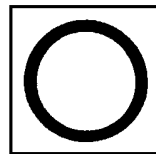

Off

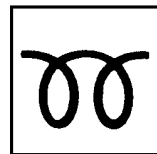

Pre-heat



Rotational speed control



Linear speed control



Tachometer



Elapsed hours

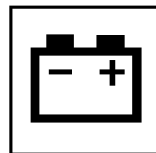

Battery charging

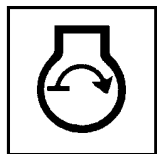

Engine cranking



Electrical hazards



General hot surface warning

Lashing down & lifting points

General

Care should be taken when lifting or transporting the mixer to ensure that lifting or retaining straps are in good condition and the following procedures must be followed when lifting or lashing down to avoid causing unnecessary damage.

It is recommended that chains or webbing slings are used to lift the mixer via the lifting eyes on the trunnion (**A**) and that ratchet type webbing straps are used to lash the mixer down.

Lifting the Mixer (Crane)

If the mixer is on site and the wheels are immersed in dried concrete or mortar the wheels must be freed before attempts are made to lift the mixer.

Using the tilting handwheel and locking plunger, lock the drum upside down as illustrated.

To prevent the drawbar swinging freely as the mixer clears the ground, turn it through 180° and hook it to the stowage point below the mainframe

Attach suitable lifting equipment to the lifting eye (**A**) and slowly take the weight.

Do not 'snatch' the mixer otherwise damage may be caused to the lifting eye, lifting equipment or to the mixer itself.

Be aware that the mixer will tend to swing as it clears the ground.

Lifting the Mixer (Forklift/Telehandler)

If the wheels are immersed in dried concrete or mortar, free them before attempting to lift the mixer.

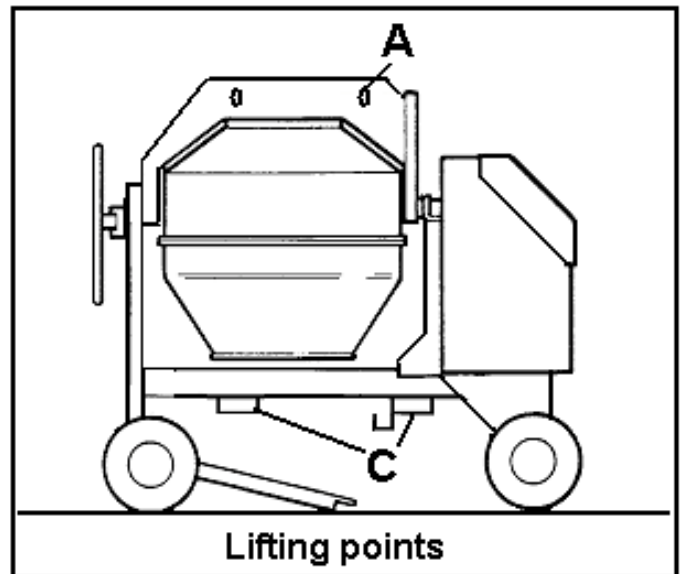

Using the tilting handwheel and locking plunger, lock the drum upside down as illustrated.

To prevent the drawbar swinging freely as the mixer clears the ground, turn it through 180° and hook it to the stowage point below the mainframe (**B**).

Spread the fork tines and carefully position them so that they pass through the brackets (**C**) that are attached to the mainframe.

Position the carriage as close as possible to the mixer

Slowly tilt the carriage back slightly to prevent the mixer rocking forward, then raise the mixer just clear of the ground.

Do not raise the mixer unnecessarily high. Keep the height to the minimum required to clear any obstructions without unduly obstructing your forward vision.

When travelling keep your speed to the minimum and when loading vehicles do not raise the mixer to the height of the bed until the mixer is close to the vehicle.

Similarly when unloading vehicles lower the mixer just clear of the ground as soon as it clears the side of the vehicle.

Lashing down

The drum should be locked in the upright position, as illustrated, to keep the centre of gravity as low as possible.

It is recommended that unless the mixer is pulled up against a headboard or some form of substantial wheel chocks that two ratchet type webbing straps are used to retain the mixer, one pulling to the rear and one pulling to the front.

Position the mixer on the vehicle bed and chock the rear wheels to prevent it rolling until lashed down.

Turn the front axle so that the drawbar is below the mixer and hook it to the stowage point below the mainframe.

Pass one of the webbing straps through the holes in the trunnion at point **(D)** and secure the strap down to retaining hooks on the vehicle bed in front of the mixer.

Pass the second strap through the holes in the trunnion at point **(E)** and secure the strap down to retaining hooks on the vehicle bed to the rear of the mixer.

Tighten the straps by means of the ratchets until the mixer is securely held.

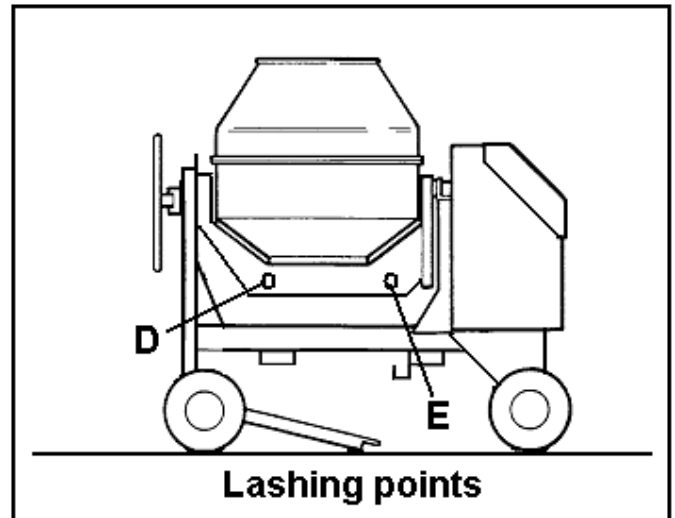

Installing the mixer on site

Incorporated into the mainframe and trunnion are lifting points. These are provided to assist with loading or unloading the mixer and for transportation across site.

WARNING *For mixer weights, see "Specifications"*



Never carry mixers by their lifting points on public roads.

Do not tow mixers across uneven ground.

The ground on which the mixer is operated must be level and stable. Ensure that the wheels are properly chocked.

Engine operation

WARNING *As soon as the engine has started the mixing drum will begin to rotate.*



Before starting the engine:

Ensure the engine and drum are free to turn without obstruction.

Check that the lubricating oil level is correct. The oil sump must be filled to the 'full' mark on the dipstick; do not overfill.

Check that the fuel supply is adequate and the system is primed.

Check that the starting handle is in good condition and clean

Electric key start machines only:

Ensure that the battery is connected, fully charged and serviceable.

Engine Safety

WARNING *The following pages of engine operating instructions are of a general nature and should be read in conjunction with, or substituted by the engine Manufacturer's instructions.*



Starting any diesel engine can be dangerous in the hands of inexperienced people.

Before attempting to start any engine the operator should read the 'Safe Working' section of this book and be conversant with the use of the engine controls and the correct starting procedures.

ETHER BASED COLD START AIDS IN AEROSOL CANS MUST NOT BE USED UNDER ANY CIRCUMSTANCES.

EXHAUST GASES CONTAIN CARBON MONOXIDE WHICH IS A COLOURLESS, ODOURLESS AND POISONOUS GAS THAT CAN CAUSE UNCONSCIOUSNESS AND DEATH.

LV1-910 engines

Description

- A Dipstick
- B Lubricating oil filler
- C Engine control
- D Decompressor lever
- F Fuel tank

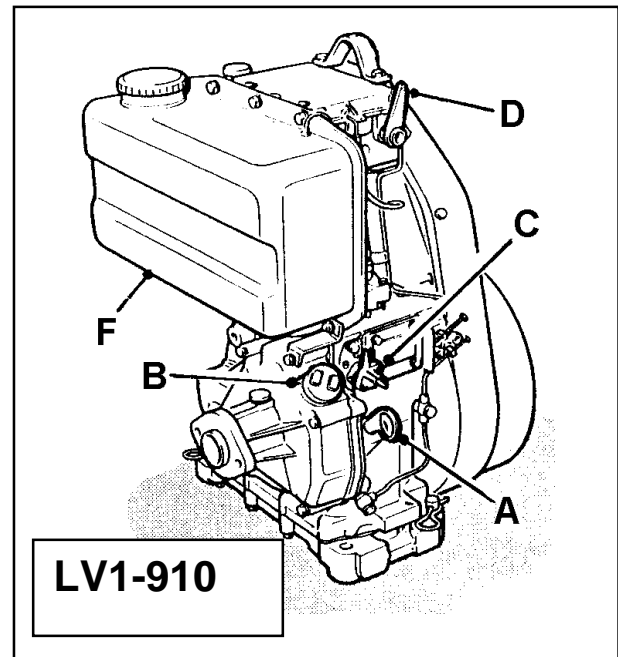

The cold start aid (*where fitted*)

The cold start aid is fitted to the combustion air intake port and is used when the ambient temperature is below -10 deg.C (14 deg.F).

With the fuel turned on, turn the engine for up to 20 revolutions to prime the fuel and lubrication systems.

Withdraw the plunger (A) and fill one third of the cup (B) with the same type of lubricating oil as used in the engine.

Replace the plunger and inject the oil just before starting the engine.

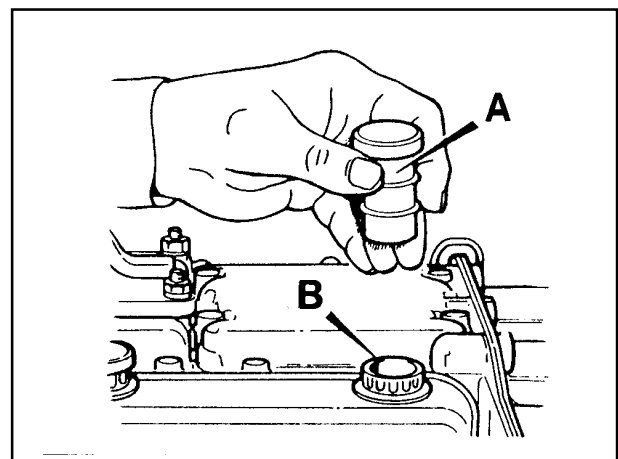

WARNING *The device must not be used more than three times in succession during the same attempt to start the engine.*



The starting handle(s)

A non-limited kick-back handle (C) or limited kick-back handle (D) system may be fitted to the engine.

The two handles are not interchangeable and care must be taken to ensure the correct type is retained with the engine.

Always use the correct starting handle which has been designed for the engine.

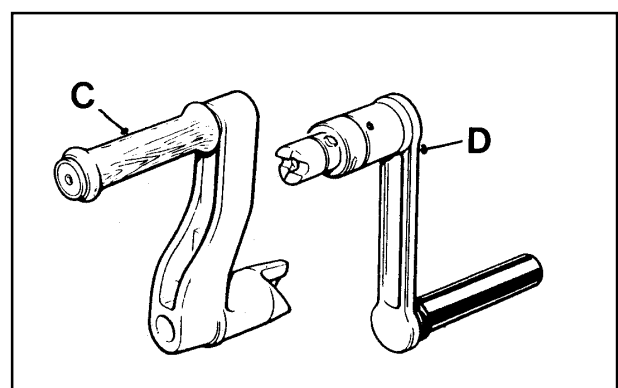

Ensure there are no burrs on the handle.

Before attempting to use the handle, clean and lightly oil that part of it which fits onto the engine.

Hand starting the engine

Select the excess fuel position by gently pulling the engine control lever (**L**) outward over the middle catch (**M**) and turning it fully clockwise.

Move the decompressor lever towards the flywheel (**N**).

Insert the correct handle (See: 'Starting handles') into the starting housing.

Turn the engine slowly for up to 20 turns to prime the combustion chamber and lubricating oil system.

Maintaining a firm grip on the starting handle, crank the engine really fast and when sufficient speed is obtained move the decompressor lever towards the gear end and continue to crank until the engine fires.

Retain a firm grip on the handle and remove it from the engine.

Turn the engine control lever (**L**) anti clockwise to the normal running position at (**M**).

Close the engine lid and ensure that it stays closed while the engine is running.

WARNING Do not stop the engine with a load in the drum.



Stopping the engine

Turn the engine control anti-clockwise to the STOP position and hold it there until the engine comes to rest.

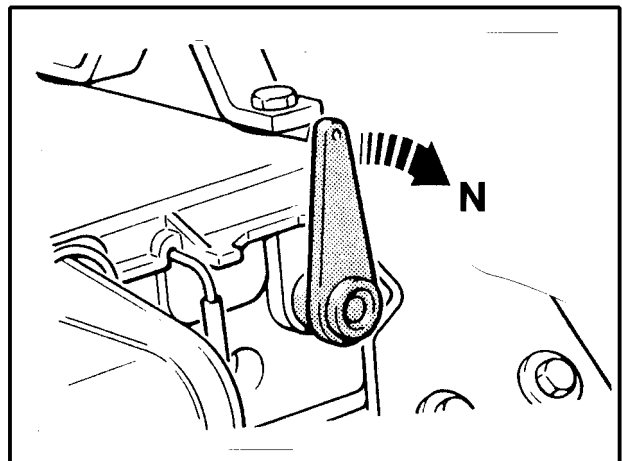
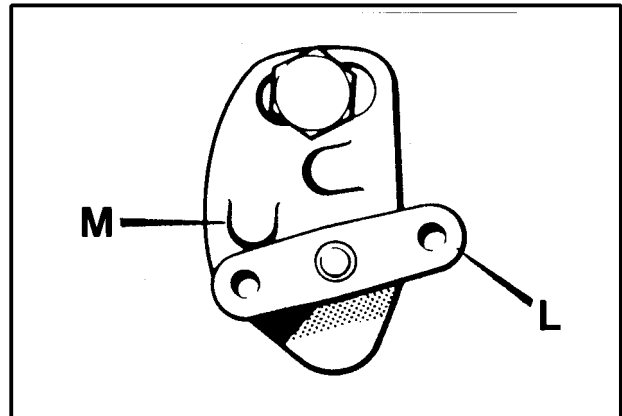

WARNING Never stop the engine by using the decompressor lever, or valve damage may occur.



Yanmar L48ARE-SE/L48N5SJ1 /L48V5V

Description

- A Fuel cock
- B Engine speed lever
- E Starting key

Electric starting the engine

Open the fuel cock (A). Put the engine start lever to the RUN position (B).

Turn the starting key (E) clockwise to START position.

Remove your hand from the key as soon as the engine starts.

If the engine does not start after 10 seconds, wait for another 15 seconds before attempting to start again.

WARNING



If the starter motor is turned for too long, the battery will go flat and motor seizure will occur. Always leave the starting key turned on, in the ON position, while the engine is running.

Check monthly that the battery fluid is at the correct level.

Cold Starting, NOT L484V5V

In cold weather, if the engine is hard to start, remove the rubber plug of the rocker arm cover and add 2cc of engine oil before starting. Do not add more than 2cc of engine oil to prevent internal engine damage.

WARNING



Never use any cold starting aids such as ether (Easy start), gasoline, paint ether or other volatile liquid or gas.

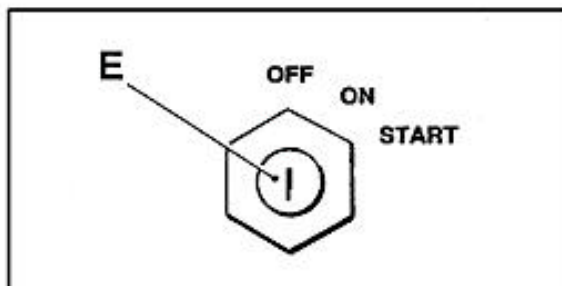
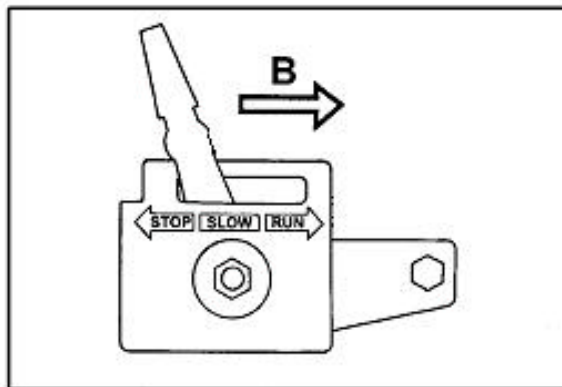
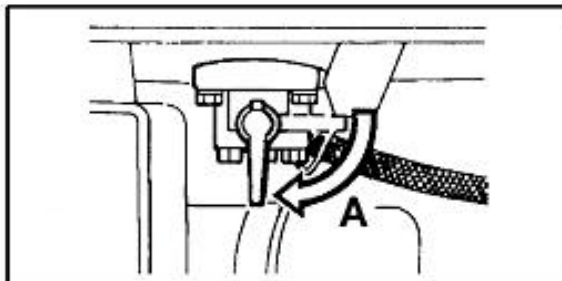
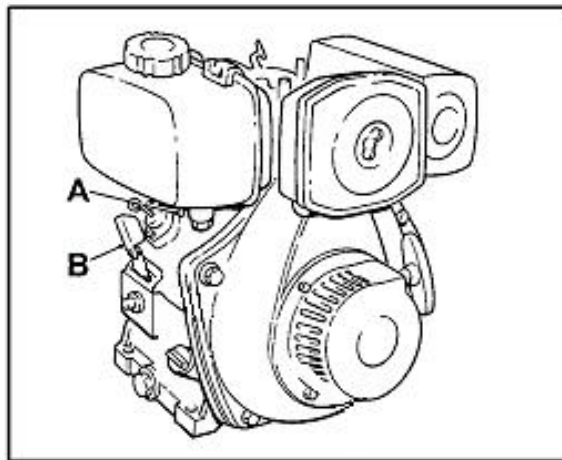

Keep the rubber plug in the cover except when adding oil. If the plug is not in place, rain, dirt and other contaminants may enter the engine and cause accelerated wear of internal parts.

Yanmar L48ARE-SE/L48N5SJ1 /L48V5V

Stopping the engine

Return the engine speed lever to the STOP position by depressing the red button on the stop control to release this control into the STOP position.

With electric-start engines, turn the starter key to the OFF position.

Set the fuel cock lever to the CLOSED position.

Slowly pull out the recoil handle until pressure is felt (that is, to the point in the compression stroke where the intake and exhaust valves are closed), and leave the handle in this position. This prevents rust from forming while the engine is not in use due to condensation.

WARNING



If the engine keeps on running even after the speed lever is placed at STOP position, stop the engine by closing the fuel cock.

Do not stop the engine with the decompression lever.

Emergency Stop Cable (where fitted)

In the event of an emergency pull the emergency stop cable located on the RH side of the engine housing

Yanmar L48ARE-SE/L48N5SJ1 /L48V5V

Manual starting in the event of a flat battery

Description

- A Fuel cock
- B Engine speed lever
- C Decompression lever
- D Recoil starting handle

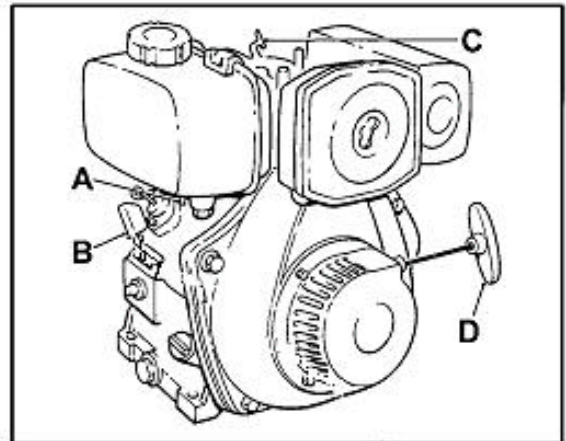

Starting the engine

Open the fuel cock **(A)**.

Put the engine start lever to the RUN position **(B)**.

Turn the start key to ON.

Pull out the recoil starting handle **(D)** slowly until you feel a strong resistance, then return it to the initial position.

Push down the decompression lever **(C)**. It will return automatically when the recoil starter is pulled.

Grip the recoil starting handle **(D)** firmly with both hands. Pull the rope hard and fast. Pull it all the way out.

The engine should now have started. If it has not, repeat the procedure.

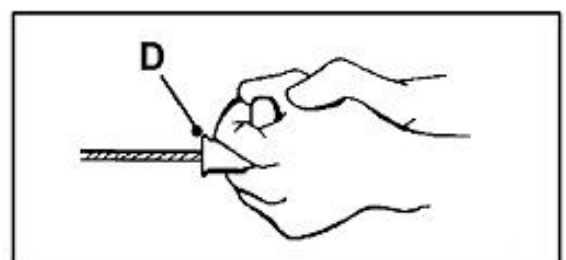
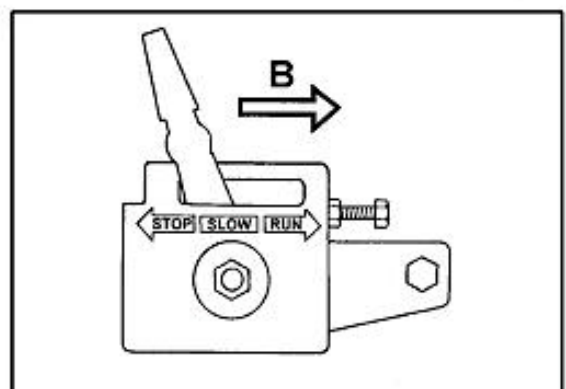
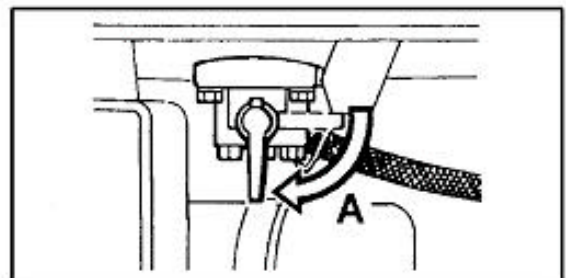

Cold Starting, NOT L48V5V

In cold weather, if the engine is hard to start, use the same cold start procedure as described on page 2.4.

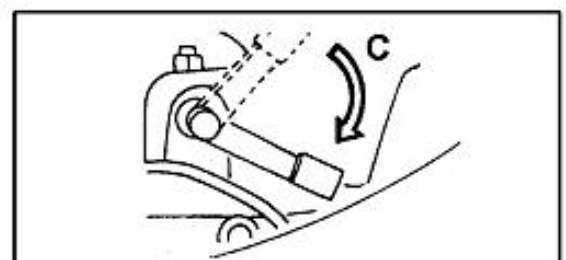

Before mixing

The operator must calculate the correct percentages of water and aggregates to be mixed.

WARNING *Cements can cause skin irritation; wear protective clothing.*



Mixer drum positions

The locking plunger (54) holds the mixing drum in one of the following positions *Charge and Mix (1)* or *Discharge (2)*.

To release the handwheel: Rotate the plunger (A) until the cross-pin (B) aligns with the slot (C), then pull the plunger outwards (D).

To lock the handwheel: Align the plunger with the appropriate hole in the frame, then push (E) and rotate the plunger until the cross-pin is vertical (F).

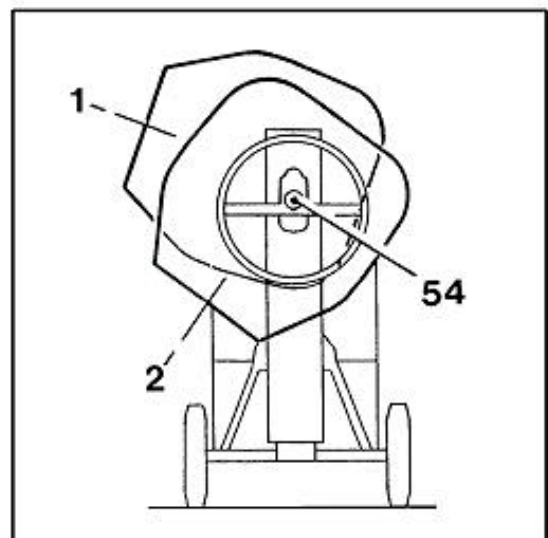

Mixing

Turn the drum to *Charge and Mix* position (1).

With the mixer running; charge the drum with the correct percentages of water and aggregates, then allow mixing to continue for about two minutes.

Ensure that a suitable container has been positioned by the side of the mixer to catch the discharging load.

Turn the drum to *Discharge (2)*, and allow the load to run into the container.

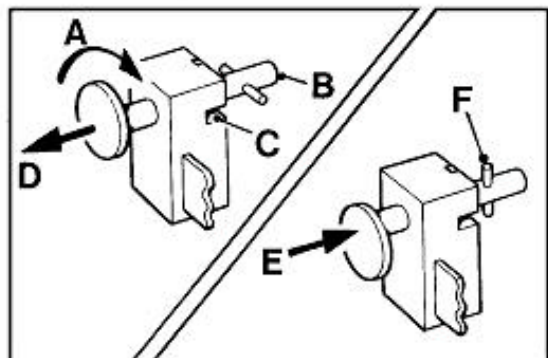

At the end of the working day

- A** Thoroughly clean out the mixing drum with water and gravel.
- B** Stop engine, and remove the starting handle and or start key to prevent unauthorised use of the machine.
- C** Grease the machine.
- D** If the mixer has a diesel engine, fill the fuel tank.
- E** Ensure the mixer is secured to prevent theft

SERVICE SCHEDULE

(See also the relevant Engine Workshop Manual)

YANMAR ENGINES
 For servicing Yanmar engines, see the engine 'Operation Manual'

Every day	
Links & hinges:	Lubricate.
Shafts & bearings:	Lubricate.
Engine: (see Engine Manual)	Check fuel and lubricating oil levels. Check for oil and fuel leaks. Clean/replace air cleaner element under very dusty conditions

Every week (or 50 hours running) The above and following items	
Nuts, bolts and keys.	Tighten (Each week for first month).
Drive chains & Belts:	Lubricate & check tension, check V belt tension on ES engines.
Drum Bevel Gears:	Lubricate with open gear fluid.

Every 125 hours. The above and following items	
Engine:	Clean/replace air cleaner element under moderately dusty conditions.
Battery (where fitted):	Check condition.

Every 250 hours. The above and following items	
Nuts, bolts & keys:	Tighten.
Engine:	Change lubricating oil. Check valve clearance. (see Engine Manual). Clean/replace injectors if exhaust is dirty. (see Engine Manual) Renew fuel filter element if the fuel is not perfectly clean.

Every 500 hours. The above and following items	
Engine:	Replace air cleaner element. Check exhaust and induction for leaks, damage or restrictions. Renew fuel filter element. Check battery charge winding system. (see Engine Manual)

Every 1000 hours. The above and following items	
Engine: (see Engine Manual)	Decarbonise if the engine performance has deteriorated. Clean cylinder barrel and head fins. Clean restrictor banjo union at the cylinder head end of the oil feed pipe. Flush and refill fuel tank.

Every 5000 hours. The above and following items	
Engine:	Major overhaul, if necessary. (see Engine Manual)

SERVICING PROCEDURE

Greasing and lubrication

WARNING *It is essential that oils and grease used for servicing do not become contaminated with sand or cement dust.*



Every day

Apply a little engine oil to pins, joints and hinges etc. to ensure that they move easily and are free from corrosion.

Shafts and bearings fitted with grease nipples must be greased using a good quality medium grease.

Bearings must not be allowed to run dry. When greasing it is better to give a little frequently rather than a lot at long intervals.

Drum drive

Every week (or 50 hours running)

Lubricate drive chains **(A)** with a little engine oil. (Do not oil the belts of Yanmar engined machines.)

Check the tension of the chains and adjust if necessary as follows:

- 1 On the slack side of the chain there should be free movement equal to the length of one pitch of the chain.
i.e. If the pitch of the chain is 20mm, then the movement on the slack side should be 20mm.
- 2 Never over-tighten the chain as this will put excessive strain on engine bearings causing vibration and wear.

Lubrication Points

Number of points

A	Drive chains	Oil	2
B	Trunnion pivots	Grease	1
C	Tilt wheel	Oil	1
D	Wheels (Solid rubber)	Oil	4
E	Steering joint	Oil	1
F	Locking plunger	Oil	1

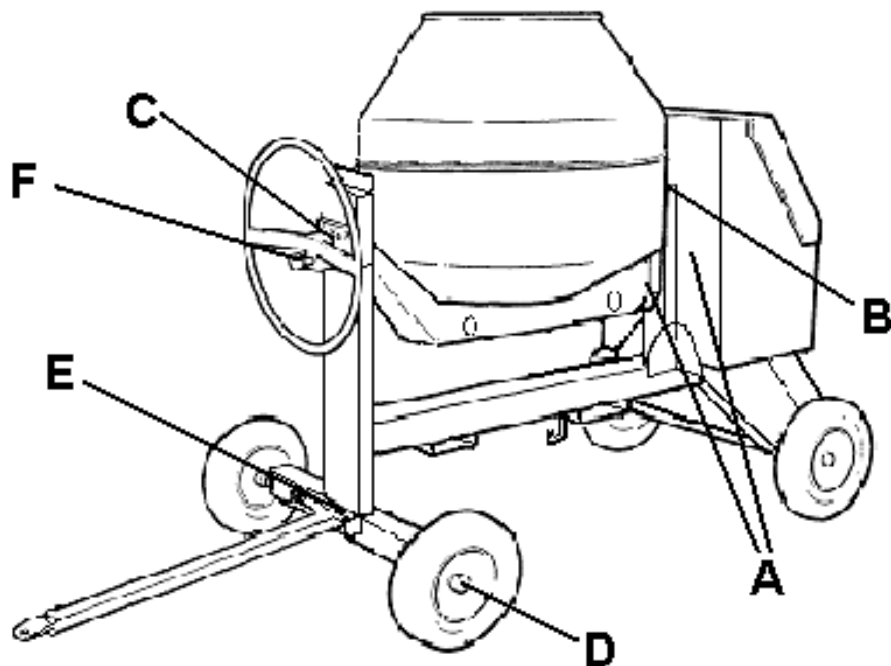

Bolt torques

Every week for the first month, then every three months

Check the tightness of all bolts, nuts, and keys etc. Pay particular attention to engine mounting bolts.

Engine, general servicing

Under very dusty conditions, air cleaners, lubricating oil and fuel filters will require more frequent attention. (see the "Service Schedule" on page 3.1)

WARNING



The materials used in the manufacture and treatment of some filters and elements may cause irritation or discomfort if they come into contact with the eyes or mouth and they may give off toxic gases if they are burnt.

Air cleaner

Every day or 125 hours (see schedule)

Change the LV1-910 air cleaner as follows:

Remove the cover (**D**) by removing the centre bolt.

Remove the old element (**E**) and fit a new one.

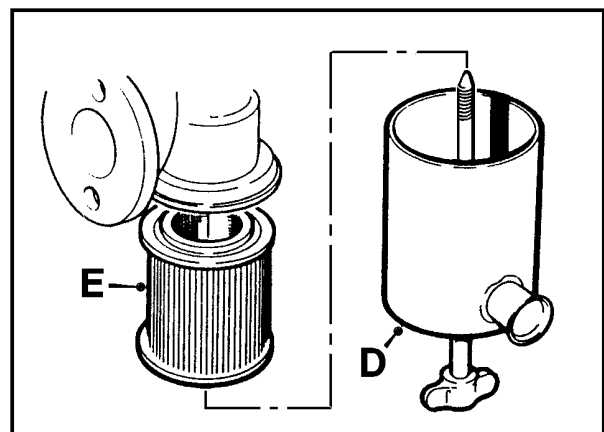

Engine lubrication oil

Every day

Check lubrication oil level with the dipstick. Top up if necessary.

Every 250 hours

Drain and refill the oil sump as follows:

WARNING



Dispose of waste oil into waste oil storage tanks. If storage tanks are not available, consult your Distributor or local authority for addresses of local designated disposal points. It is illegal to dispose of waste oil into drains or water courses, or to bury it.

Oils and fuels can cause skin irritation. Wear suitable protective clothing to prevent skin contact.

If possible run the engine immediately before draining the oil.

Place a suitable container under the drain plug. Remove the drain plug **(A)** and drain oil.

Replace the drain plug **(A)** taking care not to overtighten it.

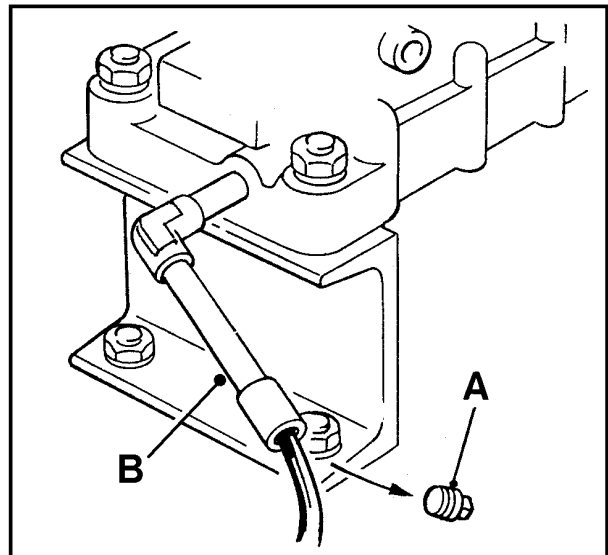

Fuel filter

Every 250 hours or 500 hours (see schedule)

Before changing the filter read the warnings in the "Safe working" section of this handbook.

Change LV1-910 fuel filters as follows:

- Remove the retaining bolt or plug (H).
- Remove the old element (I) and joints (J).
- Fit a new element and new joints.
- Replace and tighten the retaining bolt or plug (H).
- Prime the fuel system.

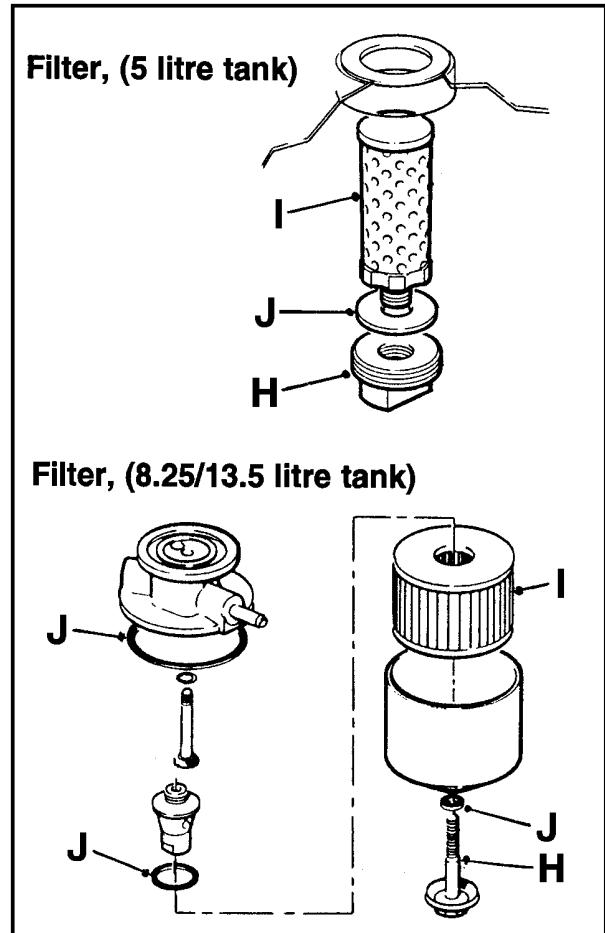

Prime LV1-910 fuel system as follows:

- Fill the fuel tank.
- Move the engine control lever to the 'RUN' position.
- Vent the filter through bleed screw (G) until a full air free flow of fuel is obtained.
- Vent fuel through the pump bleed screw (K) until a full air free flow of fuel is obtained.

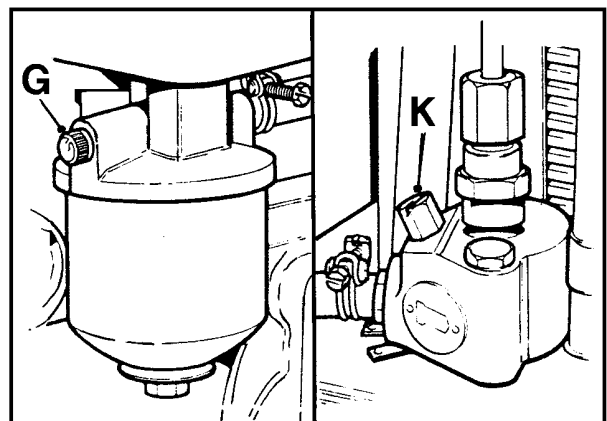

Battery

WARNING

*BATTERIES CONTAIN
SULPHURIC ACID WHICH
CAN CAUSE SEVERE
BURNS AND PRODUCE
EXPLOSIVE GASES.*

*If the acid has been splashed
on the skin, eyes or clothes
flush with copious amounts of
fresh water and seek
immediate medical aid.*

Check the battery as follows:

Wear protective gloves and goggles.

Clean the top of the battery filler plug area.

Remove the filler plugs and check that the electrolyte level is 6.0-9.0mm (0.25-0.37in) above the tops of the separators.

If necessary top up with distilled water.

In cold weather distilled water should only be added immediately before running the engine.

Replace and tighten the filler plugs.

Check that the terminal connections are tight; petroleum jelly will help to protect them from corrosion.

Mixer drum assembly

The drum is manufactured in two halves joined together by a drum clip. This allows either half to be replaced separately.

Some export machines are delivered with the drum cone and blades detached. This is to aid shipping.

There are two methods of reassembling the two halves of the drum, they are:

1 Assembling drum using special clamping tool.

(The special clamping tool, part number 513204000 can be obtained from any Winget distributor.)

- A** Bolt the two blades into the drum base **(1)**. Tighten the bolts with fingers only.
- B** Smear silicone sealant around the mating flanges of the cone **(2)** and drum base **(3)**. (see 'Specifications' for mixer drum sealant)

WARNING *When applying silicone sealer, prevent contact with skin by wearing suitable gloves.*



- C** Lift the cone **(2)** over the blades and position it on the drum base **(3)**.
- D** Turn the cone until the two holes at the top of each blade **(4)** align with the holes in the cone. Fit bolts and tighten with fingers only.
- E** Smear silicone sealant around the inside face of the drum clip **(5)** (leave 150mm each end of the clip clear of sealant to avoid risk of fire when welding).
- F** Locate the drum clip around the periphery of the drum base and cone flange.

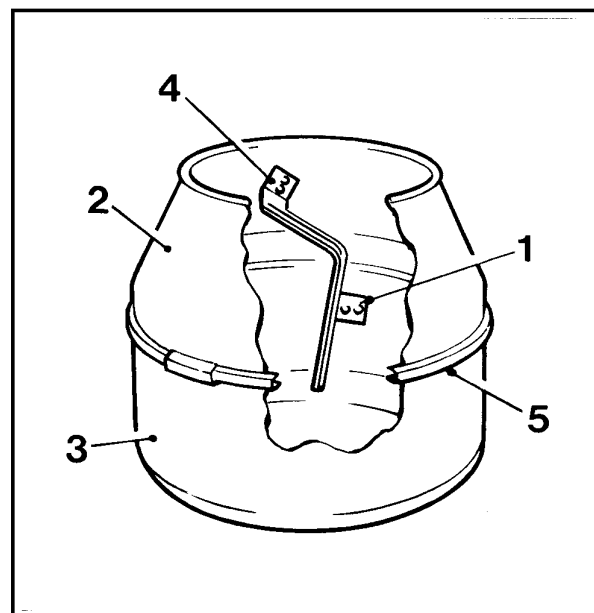

- G** Locate the clamping tool (7) into the two holes (8) of the drum clip. Tighten the tool securely using a suitable spanner.
- H** Centralise the bridge piece (9) on the drum clip between the jaws of the clamping tool.
- I** Weld the bridge piece (9) to the drum clip (5). Remove the clamping tool (7).
- J** Tighten securely all of the blade fixing bolts.

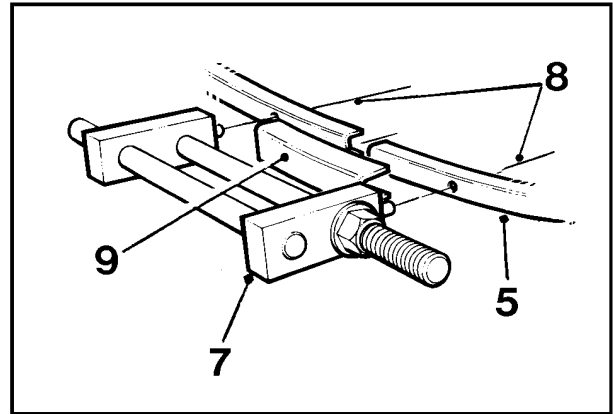

2 Assembling drum using a tourniquet.

- A** If the special clamping tool is not available a tourniquet can be used as illustrated by looping a length of rope through four blocks of wood (10), each block having a vee cut, and two holes to take the rope.
- B** Twist the rope around a bar (11) to tighten the drum clip.
- C** All other aspects of the assembly are the same as "Assembling the drum using special clamping tool".

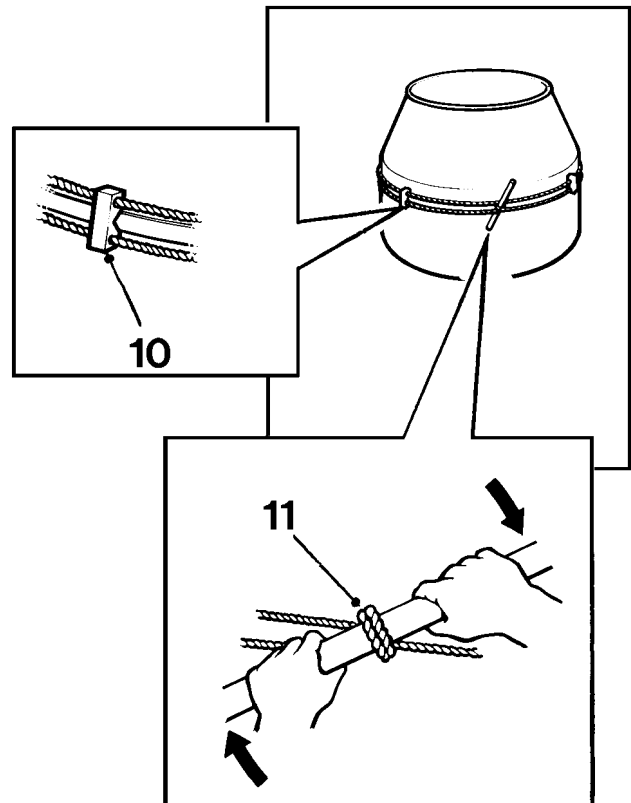

Mixer drum drive overhaul

On reassembling the drum drive, after an overhaul, the following points must be observed:

Note: It is important to pack all sealed bearings with grease prior to assembly.

A Coat with an anti-seize compound the drum shaft (**j**) at points (**a**), and the screws (**j1**).

B The bearings (**b**) on either end of the bevel pinion shaft (**d**) are sealed for life and therefore require no maintenance after initially packing with grease.

C The bevel gears (**c**) are to be coated liberally with Open Gear Fluid.

D The bevel pinion assembly (**d**) must be set horizontally in the trunnion. Do this as follows:

Ensure that the drive chain (**f**) is correctly adjusted, then set the bevel pinion assembly (**d**) horizontal by adjusting shims (**e**).

E To adjust the mesh of the bevel pinion gears proceed as follows:

Allow the bevel gear to sit fully in mesh with the bevel pinion. Check the number of washers required to fill the gap (**g**) between the drum shaft flange and the trunnion face. Remove one washer from each side, fit screws (**h**) and tighten. Backlash approx. 3mm max.

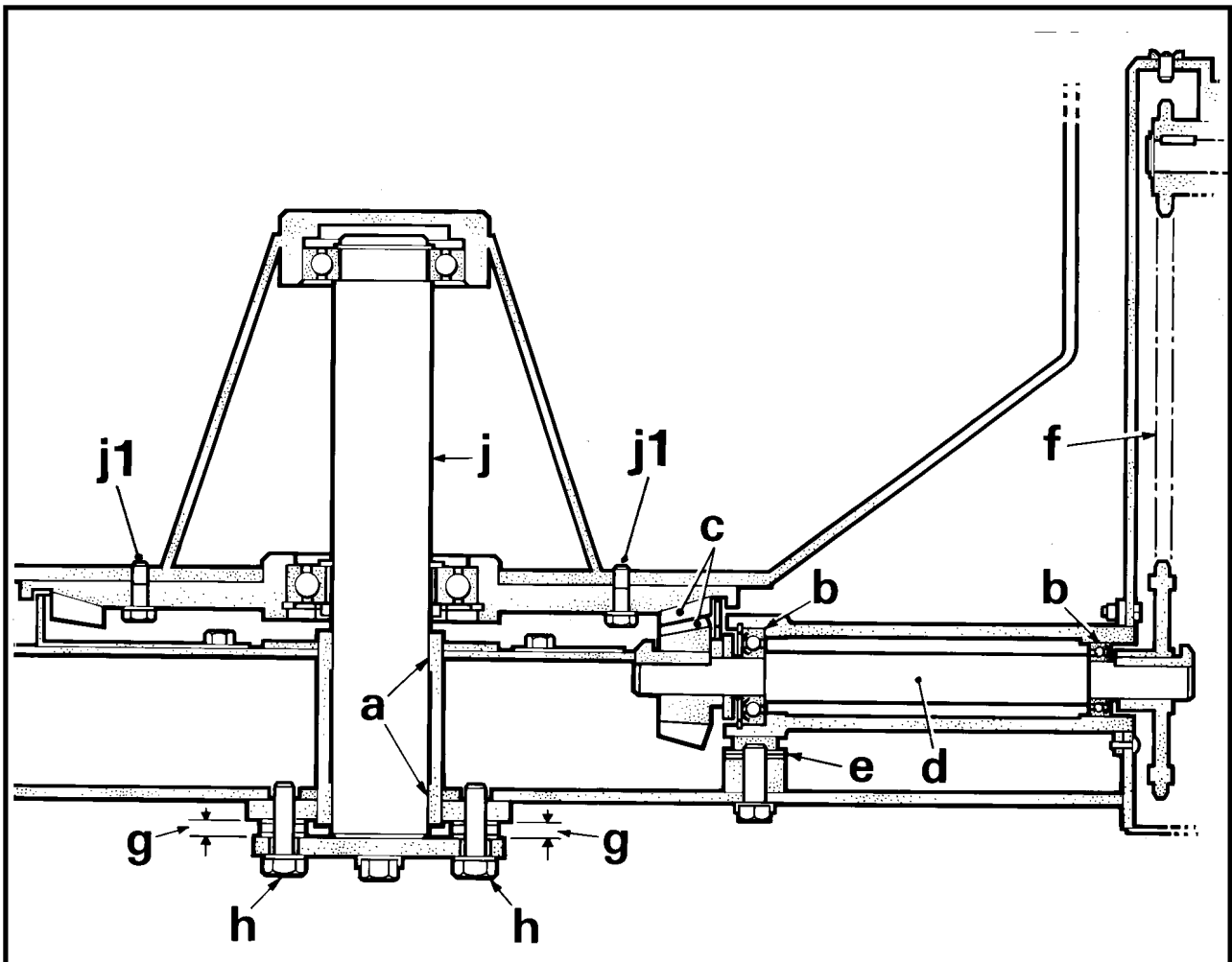

Lubricants

Mixers are factory filled with the following TOTAL oils.

Engine, LV1-910:	lubricating oil	Rubia B 10W/30	1.3 litres
Yanmar L48:	lubricating oil	Rubia B 10W/30	0.8 litres
<i>Note: In cold weather engines are to be filled with 10W oil to aid starting.</i>			
LV1-910:	fuel		5.0 or 8.25 litres
Yanmar L48:	fuel		2.5 litres

Drive chains	Rubia B 20W/30
Bevel gears	Open gear fluid
Drum shaft	Anti-seize compound
Grease nipples	Multis EP 2
Linkages, hinges, bushes, pins, wheels	Rubia B 20W/30

Noise levels of mixers

(Measured in accordance with EC Directive 2000/14/EC)

LPA 83	LWA 102	Lister-Petter LV1-910
LPA 80	LWA 101	Yanmar L48 ARE-SE/L48N5SJ1/L48V5V

Drum speed

Handbrake

22 rpm (approx.)	Tested to hold on a 5° & 10° slope with 600Kg of test weights applied
------------------	---

Mixer drum sealant

Silicone sealant	(part number V2000772)
------------------	------------------------

Lister Petter & Yanmar Engines

Lister-Petter LV1-910 (Standard) 3 kW (4 hp) @ 1500 rpm	Yanmar L48 ARE/L48N5SJ1/L48V5V (Option) 2.5kW (3.4hp) @ 3000 rpm
---	--

Dimensions

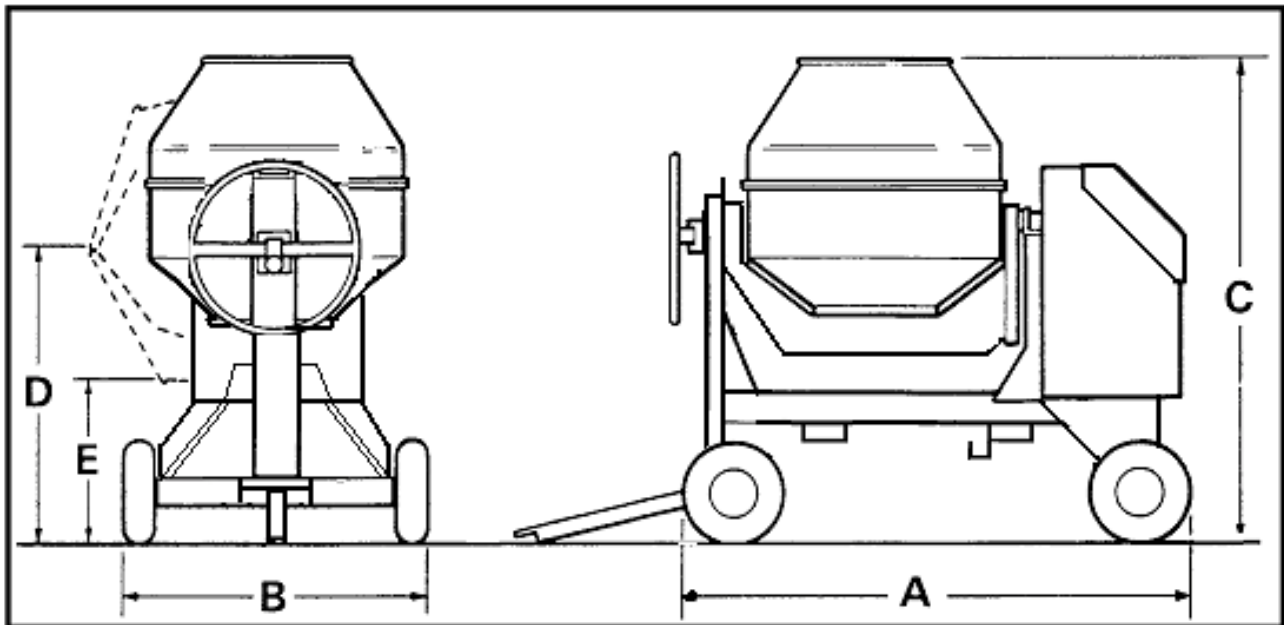

A Overall length	1980 mm
B Overall width	1110 mm
C Overall height	1815 mm
D Loading height	1220 mm
E Discharge height	510 mm
-- Weight (approx)	585 kg (LV1) 500 kg (L48)

Yanmar L48 ARE-SE/L48N5SJ1/L48V5V key start wiring circuit

In addition to the circuit shown below, the engine is fitted with its own loom.
 (see *Yanmar service literature*)

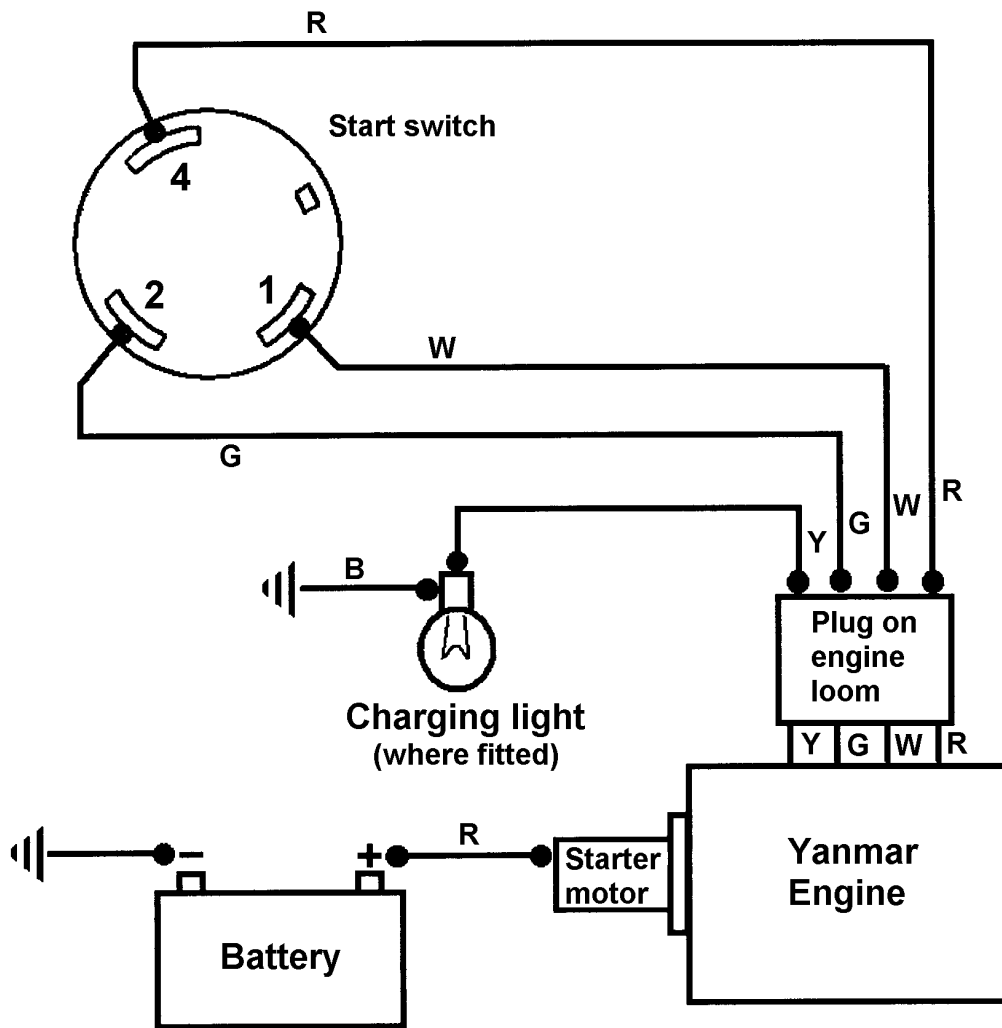

Wire colours

- R Red
- B Black
- G Green
- W White
- Y Yellow

NOTE: Wire identification

The red wire to the battery is much thicker than the red wire to the start switch.

200T MIXER

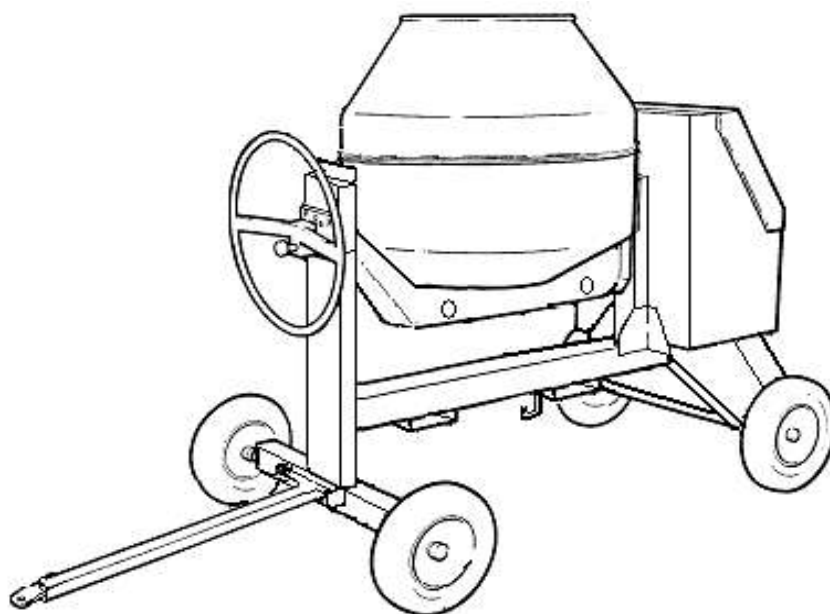

**Mixers manufactured from
serial number T200XF1333**

CONTENTS

- A - 1** **MAINFRAME & FRONT AXLE**
- A - 2** **PANELS**

- B - 1** **DRUM**
- B - 2** **TILT WHEEL**
- B - 3** **TRUNNION**
- B - 4** **DRUM DRIVE**

- C - 1** **LISTER- PETTER LV1-910 engine**
- C - 2** **YANMAR L48ARE/L48N5 electric start engine**
- C - 2A** **YANMAR L48V5VSJ1 electric start engine
(EU Stage 5 Emission Compliant)**

- C - 3** **ELECTRICS for Yanmar engine**
- C - 4** **CABLE emergency stop, L48N5SJ1/L48V5V**

- D - 1** **DECALS & PLATES**
- D - 2** **SPECIAL TOOLS**

<<< TO BEGINNING OF MANUAL

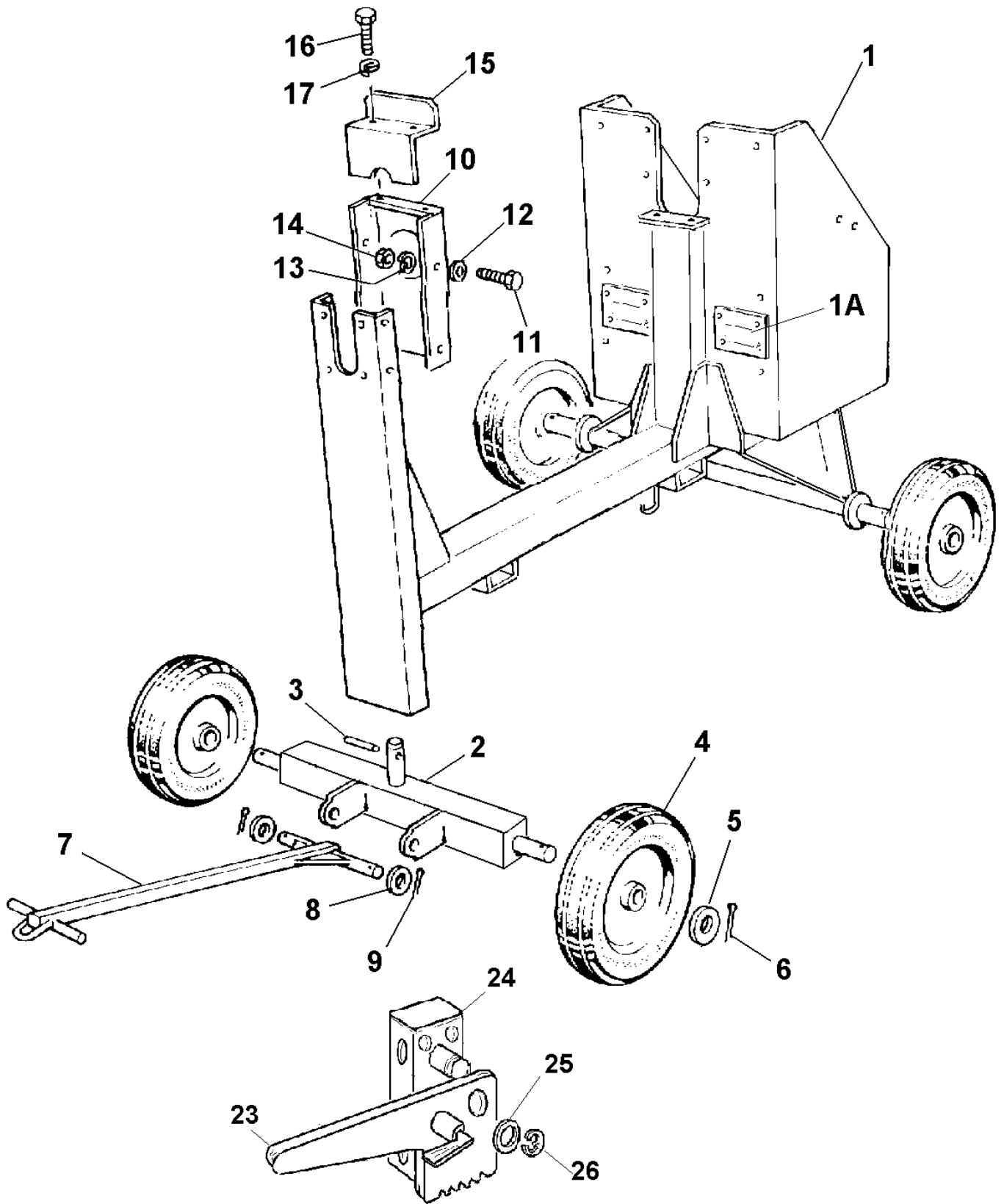

MAINFRAME & FRONT AXLE

A - 1

Item	Part no	Serial no	Description	Qty
1	513365000		MAINFRAME	1
1A	513371700	1590/	PLATE, vent	2
1B	11S02A		SCREW, set	8
1C	17S03		WASHER, spring	8
2	513367100		AXLE, front	1
3	353830650		PIN, spirol	1
4	475115000		WHEEL, solid rubber 400mm dia	4
5	10S09		WASHER, flat	4
6	44S05G		PIN, split	4
7	513341200		BAR, towing	1
8	10S17		WASHER, flat	2
9	44S03D		PIN, split	2
10	513198401		GUARD, tilt wheel lower	1
11	11S04B	/1649	SCREW, set	4
12	267S06	/1649	WASHER, flat	4
13	17S05	/1649	WASHER, spring	4
14	7S04	/1649	NUT	4
11	11S03B	1650/	SCREW, set	4
12	17S04	1650/	WASHER, spring	4
13	267S05	1650/	WASHER, flat	4
14	326S05	1650/	NUT, rivet, knurled	4
15	513198402		GUARD, tilt wheel upper	1
16	11S02B		SCREW, set	2
17	17S03		WASHER, spring	2
		1526/		
18	513371000		PLATE, handbrake mounting (not illustrated)	1
19	11S04D		SCREW, set	2
20	267S06		WASHER, flat	2
20A	V2004220		WASHER, flat, special	2
21	17S05		WASHER, spring	2
22	7S04		NUT	2
23	513370700		LEVER, handbrake assembly	1
23A	513370800		CATCH, sprung	1
24	513370600		PIVOT, bracket	1
24A	11S04C		SCREW, set, not illustrated	2
24B	17S05		WASHER, spring, not illustrated	2
24C	267S06		WASHER, flat, not illustrated	2
25	10S18		WASHER, flat	1
26	132412010		CIRCLIP	1

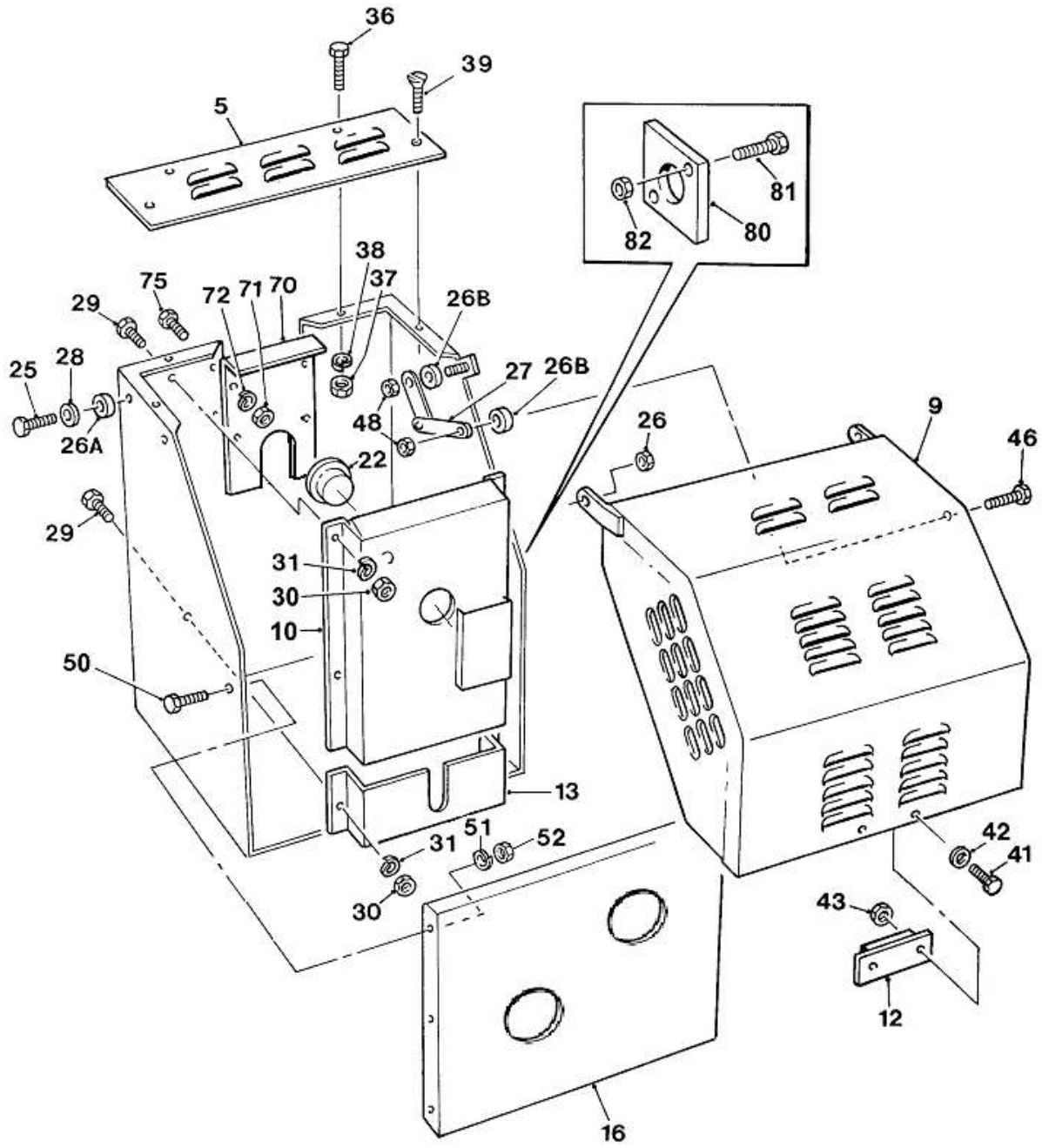

PANELS

Item	Part no	Serial no	Description	Qty
5	513287000		TOP PLATE, engine housing	1
9	513286800		LID, engine housing	1
10	513248700	/1601	GUARD, chain/belt, not L48V5VSJ1	1
10A	513371400	1602/	GUARD, belt L48V5VSJ1	1
12	513205300		STOP, rubber	1
13	513266900		GUARD, sprocket diesel, LV1 Engine	1
16	513270300		PLATE, closing	1
22	241859000		PLUG, polythene	1
25	11S04F		SCREW, set	2
26	59S03		NUT, nyloc	2
26A	555170000		SPACER	2
26B	513340800		SPACER	2
27	513287200		STAY, housing lid	1
28	267S06		WASHER, flat	2
29	11S04B		SCREW, set	6
30	7S04		NUT	6
31	17S05		WASHER, spring	6
36	11S02A		SCREW, set	2
37	7S02		NUT	4
38	17S03		WASHER, spring	4
39	52S02C		SCREW, c'sunk socket head	2
41	11S02A		SCREW, set	2
42	267S04		WASHER, flat	2
43	61S02		NUT, Binx, self locking	2
46	6S02E		BOLT, <i>obsolete use</i>	1
46	8S03E		BOLT	1
48	87S02		NUT, Binx, self locking, <i>obsolete use</i>	2
48	61S03		NUT, Binx, self locking	2
50	11S03A		SCREW, set	6
51	17S04		WASHER, spring	6
52	7S03		NUT	6
70	513368600		PLATE, infill	1
71	7S04		NUT	4
72	17S05		WASHER, spring	4
72A	267S06		WASHER, flat, not illustrated	4
75	11S04B		SCREW, set	4
80	513362600		PLATE, rope guide (<i>Yanmar engines</i>)	1
81	11S02C		SCREW, set	2
82	61S02		NUT, Binx	2

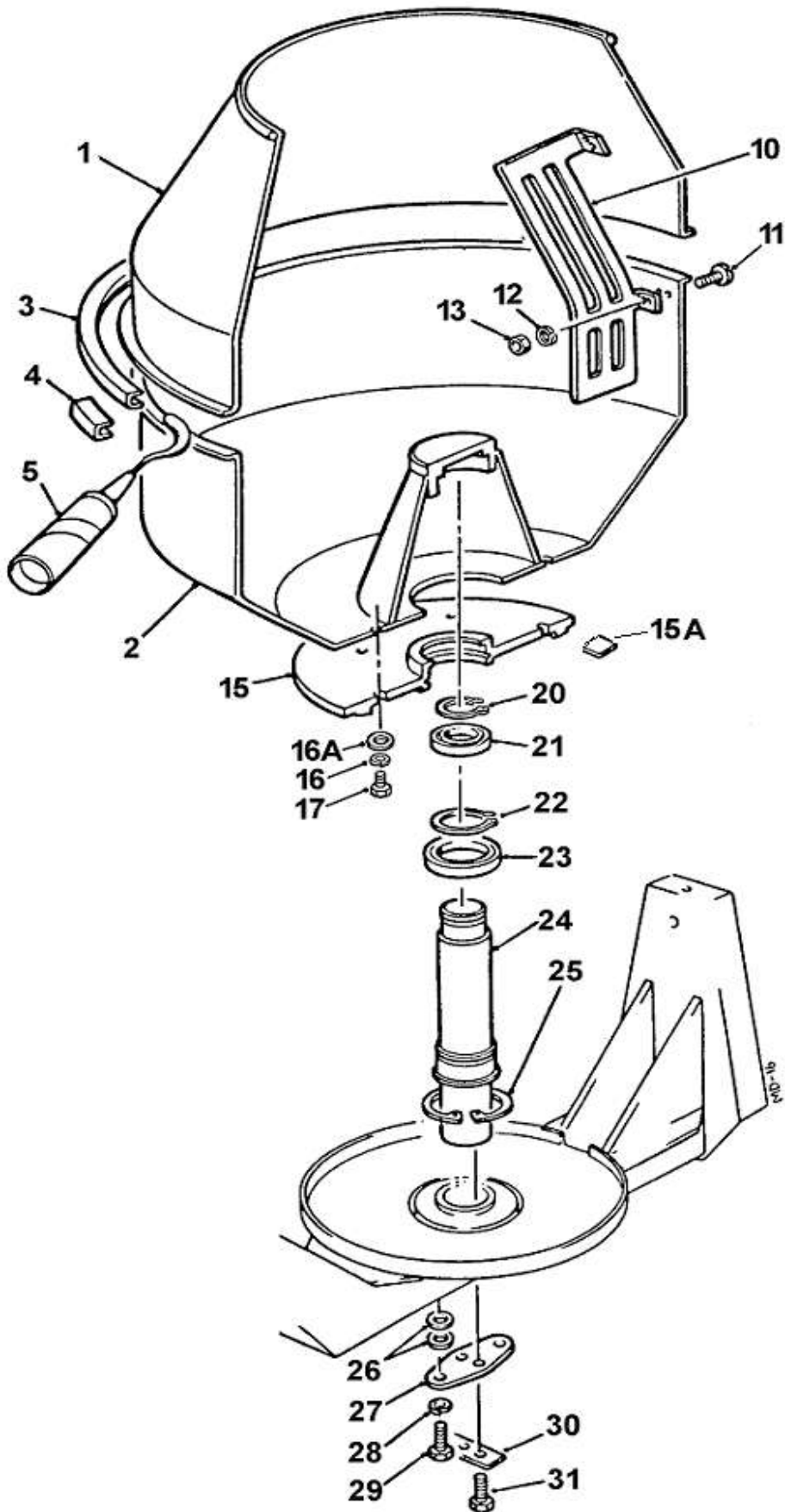

DRUM**B - 1**

Item	Part no	Serial no	Description	Qty
1	513323902		DRUM, top	1
2	513324000		DRUM, base	1
3	513324100		CLIP, drum	1
4	513324200		BRIDGE PIECE	1
5	V2000772		ADHESIVE, flexible	tube 1
10	513324300		BLADE	2
11	16S09D		SCREW, slotted panhead	8
12	17S05		WASHER, spring	8
13	7S04		NUT	8
15	513305200		GEAR, drum (with Shims	1
15A	V603964		PACKER, shim set	1
16	17S06		WASHER, spring	6
16A	267S07		WASHER, flat	6
17	11S05D		SCREW, set	6
20	132760000		CIRCLIP	1
21	88S42D		BEARING	1
22	132775000		CIRCLIP	1
23	88S45D		BEARING	1
24	513310100		SHAFT, drum	1
25	132313000		CIRCLIP	1
26	267S09		WASHER, flat, thick 3mm	AR
26A	267S20		WASHER, flat, thin 2mm	AR
26B	513375100		WASHER, shim, 0.5mm	AR
26C	513375200		WASHER, shim, 1.0mm	AR
27	513310600		PLATE	1
28	17S08		WASHER, spring SCREW,	2
29	11S06H		set	2
30	513326300		WASHER, locking strip	1
31	11S06E		SCREW, set	2

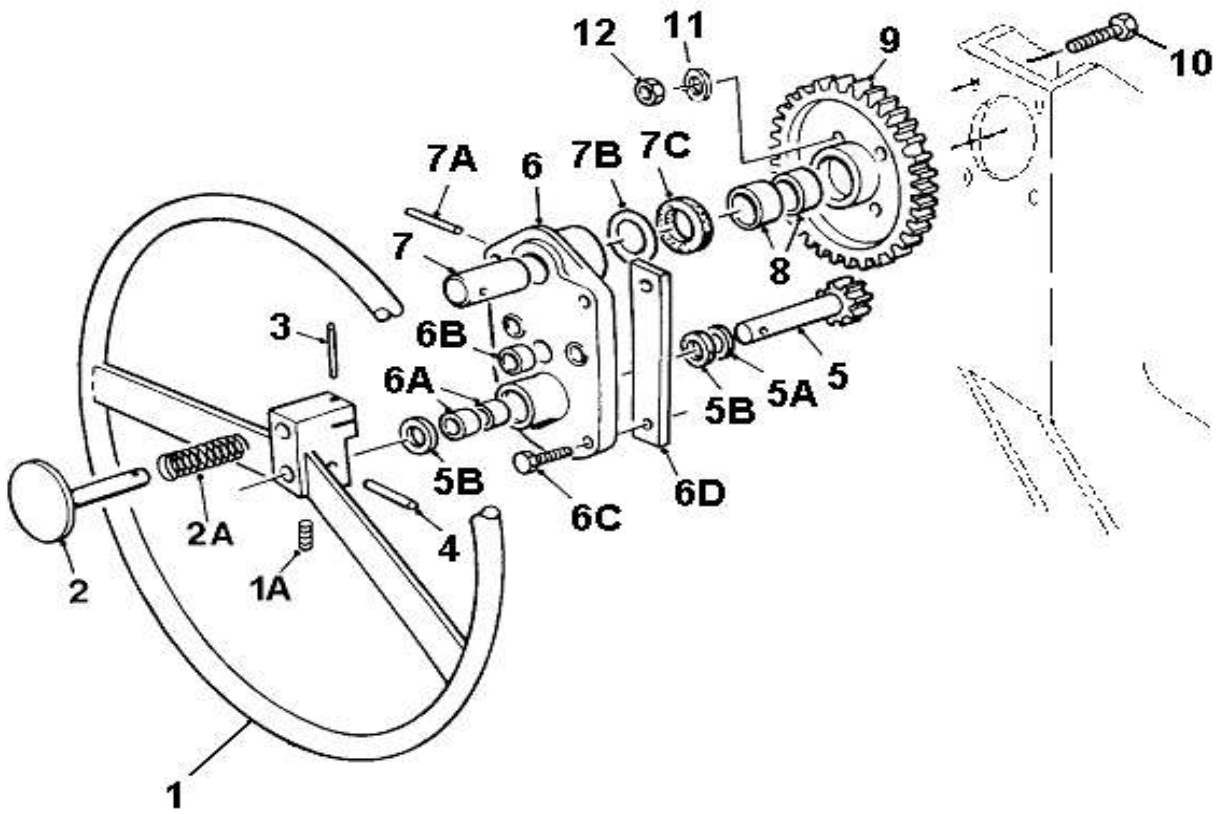

TILT WHEEL**B - 2**

Item	Part no	Serial no	Description	Qty
1	513345400		HANDWHEEL	1
1A	57S06F1		SCREW, grub	1
2	513194400		PLUNGER, locking	1
2A	513345300		SPRING	1
3	54S01A		PIN, spirol	1
4	513374900		PIN, grooved	1
5	513345600		PINION, tilting	1
5A	10S18		WASHER, flat	1
5B	225514220		SEAL, felt	2
6	513149400		BRACKET, tilting	1
6A	112821000		BUSH	2
6B	114625320		BUSH	3
6C	103S04C		SCREW, socket head cap	4
6D	513212300		PLATE, retaining	2
7	513151000		STUB, trunnion journal	1
7A	55S07Q		PIN, spirol	1
7B	10S09		WASHER, flat	A/R
7C	225520280		SEAL, felt	1
8	112820000		BUSH	2
9	513149300		GEAR, tilting	1
10	6S03E		BOLT	4
11	10S03		WASHER, flat	4
12	107S14		NUT, nyloc self locking	4

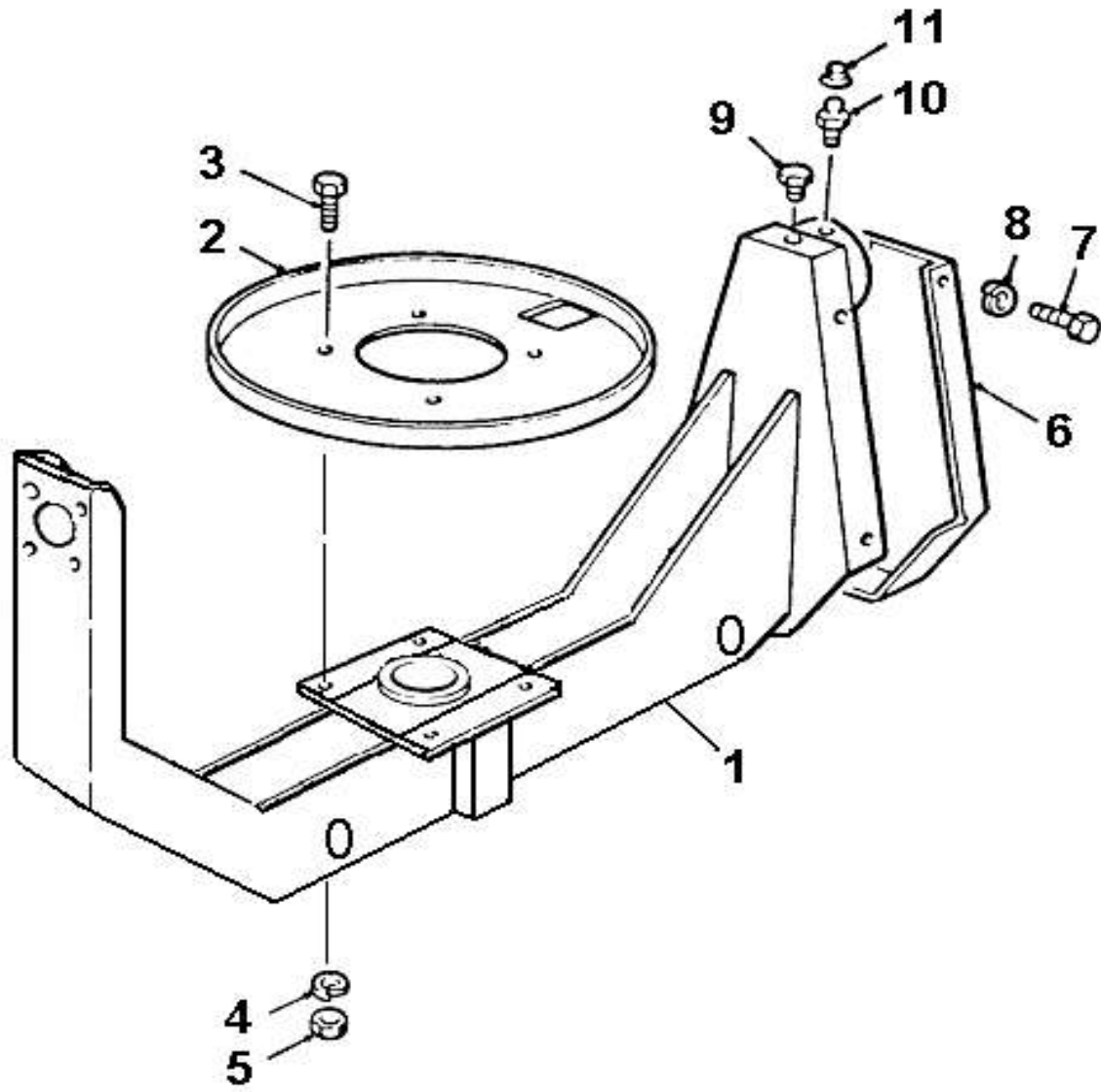

TRUNNION**B - 3**

Item	Part no	Serial no	Description	Qty
1	513367900		TRUNNION	1
2	513316500		GUARD, drum gear	1
3	11S03B		SCREW, set	4
4	17S04		WASHER, spring	4
5	7S03		NUT	4
6	513316600		COVER, chain rear	1
7	11S02AA		SCREW, set	4
8	17S03		WASHER, spring	4
9	315803100		NIPPLE, grease	1
10	131S01		NIPPLE, grease	1
11	176S01		CAP, NIPPLE	1

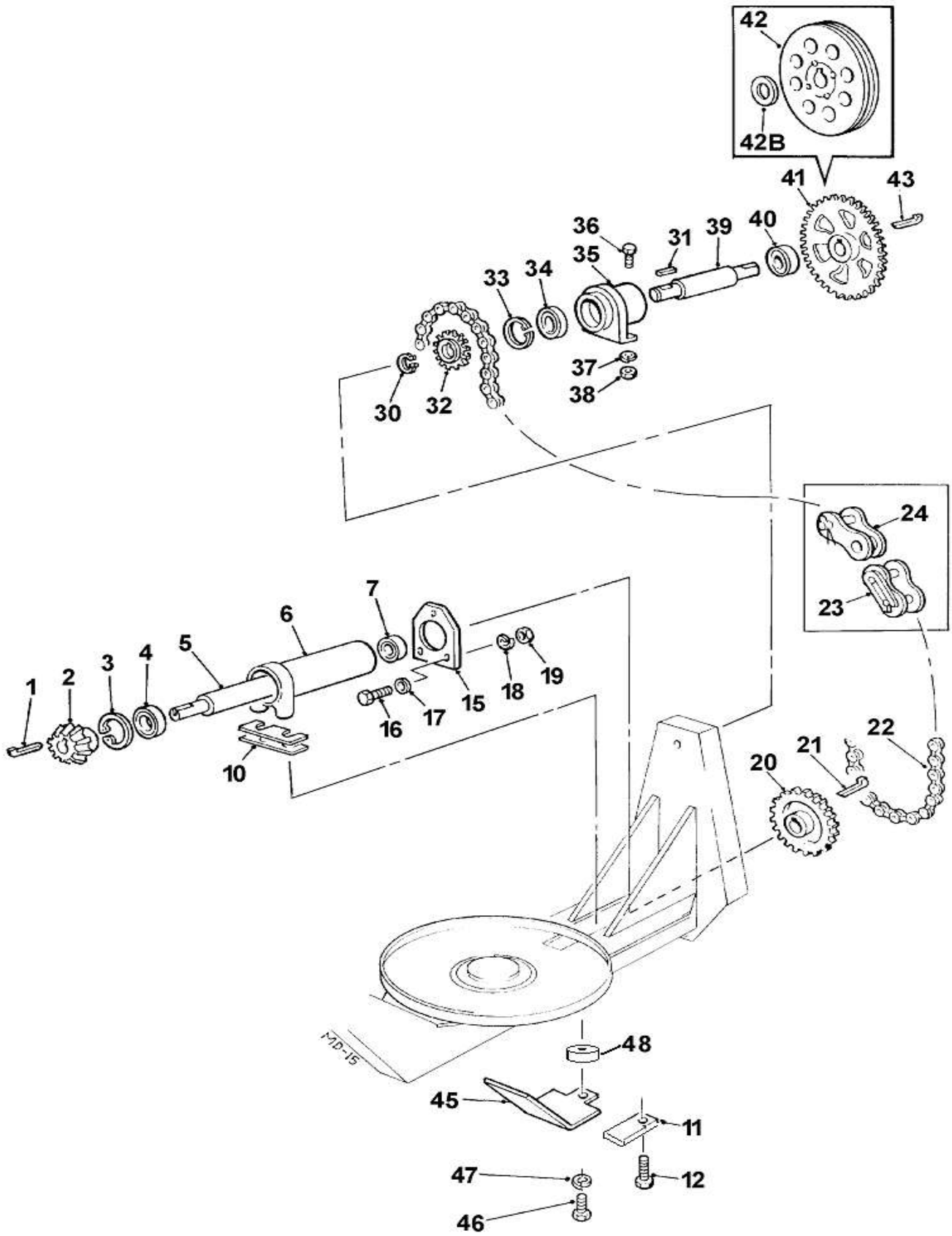

DRUM DRIVE

B - 4

Item	Part no	Serial no	Description	Qty
1	300110845		KEY, taper gib	1
2	513310700		PINION	1
3	132362000		CIRCLIP	1
4	88S05D		BEARING	1
5	513310300		SHAFT	1
6	513305400		HOUSING	1
7	88S15D		BEARING	1
10	513152400		SHIM, pack	set 1
11	513211900		TABWASHER, locking strip	2
12	11S05H		SCREW, set	2
15	513298900		PLATE	1
16	11S04C		SCREW, set	2
17	267S06		WASHER, flat	2
18	17S05		WASHER, spring	2
19	7S04		NUT	2
20	513305300		SPROCKET	1
21	300110845		KEY, taber gib	1
22	134105070		CHAIN	1
23	134105002		LINK, connecting	1
24	134105001		LINK, half	1
30	132725000		CIRCLIP	1
31	304708035		KEY, rectangular feather	1
32	513310500		SPROCKET	1
33	132362000		CIRCLIP	1
34	88S05D		BEARING	1
35	513305500		HOUSING	1
36	11S05F		SCREW, set	2
37	17S06		WASHER, spring	2
38	7S05		NUT	2
39	513310400		SHAFT, counter	1
40	88S15D		BEARING	1
41	513310800		SPROCKET, (Lister-Petter engines) or	1
42	371123000		PULLEY, (Yanmar engines)	
42A			Bush, taper lock	1
42B	267S12		WASHER, flat, thick	1
			or	
42B	267S22		WASHER, flat, thin	1
43	300110845		KEY, gib head (Lister Petter engines)	1
43A	CR329047		KEY, parallel, (Yanmar engines)	1
45	513211800		GUARD, bevel pinion	1
46	66S03A		SCREW, set, imperial or alternatively	1
46	11S04C		SCREW SET, M10, metric	1
47	41S05		WASHER, spring, imperial or	1
47	17S05		WASHER, spring, M10 metric	1
48	555170000		SPACER	1

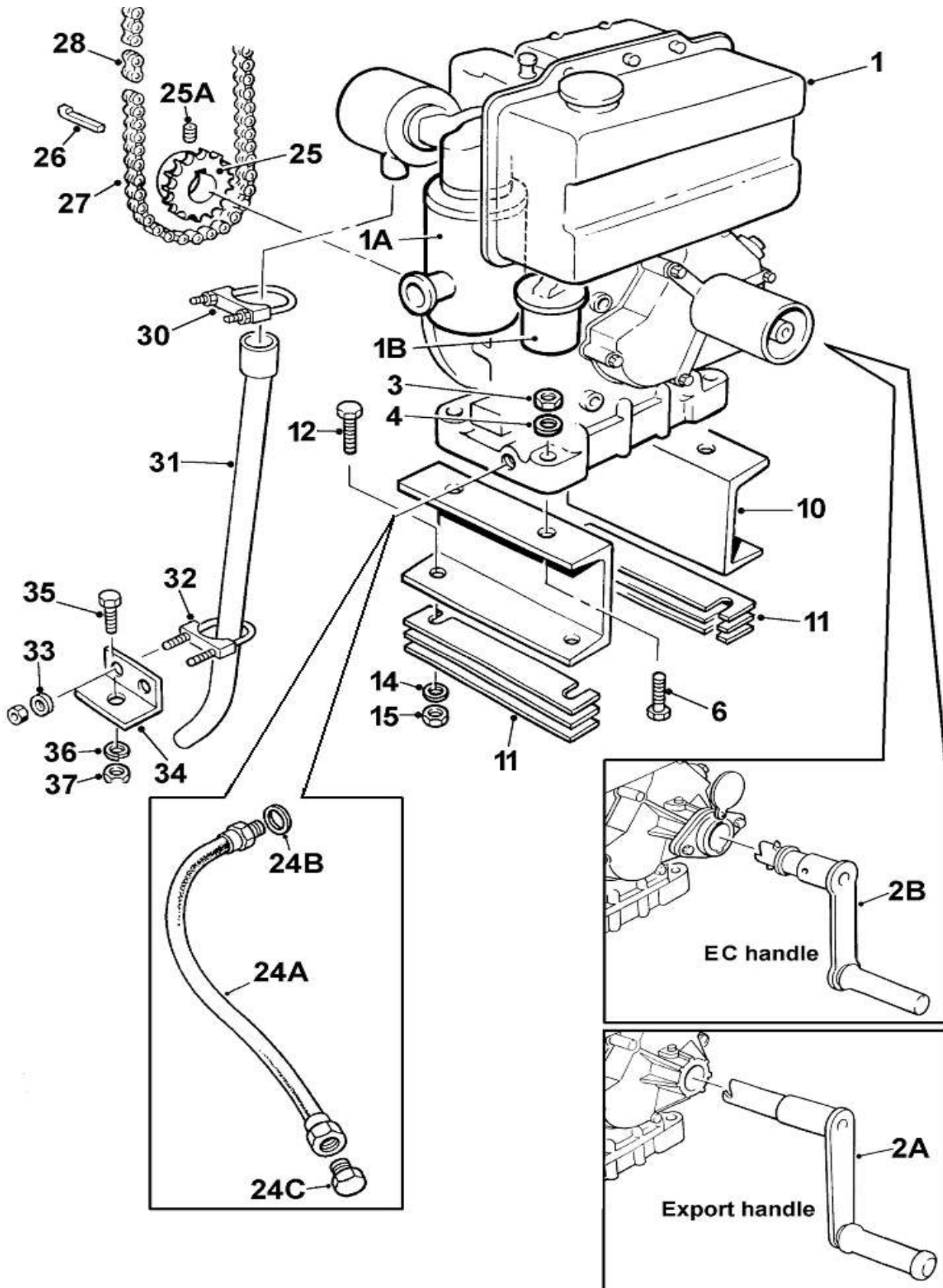

LISTER-PETTER LV1-910 engine

C - 1

Item	Part no	Serial no	Description	Qty
1	354051000		ENGINE, LV1-910 <i>"Export" without anti kickback</i>	1
1	354054100		ENGINE, LV1-910 <i>"UK/EC" with anti kickback</i>	1
1A	EL60131350		FILTER, air	1
1B	EL20113118		FILTER, fuel	1
2A	EL60252971		HANDLE, engine starting <i>"Export", without anti kick back</i>	1
2B	EL375232		HANDLE, engine starting <i>"UK/EC", with anti kick back</i>	1
3	61S05		NUT, "Binx", self-locking	4
4	267S07		WASHER, flat	4
6	8S05J		BOLT	4
10	513267400		CHANNEL, engine mount	2
11	513248400		SHIMS	(set) 1
12	8S05E		BOLT	4
14	267S07		WASHER, flat	4
15	61S05		NUT, "Binx", self-locking	4
24A	513362800		HOSE, flexible	1
24B	100S04		SEAL, bonded	1
24C	127S04		PLUG, blanking, oil drain	1
25	513326400		SPROCKET, engine	1
25A	57S05D2		SCREW, grub	1
26	300204160		KEY	1
27	134105096		CHAIN	1
28	134105002		LINK,connecting	1
—	134105001		LINK, half	AR
30	354051005		CLAMP, exhaust	1
31	513267500		PIPE, exhaust	1
32	153S01		CLAMP, exhaust	1
33	267S04		WASHER, flat	2
34	513266800		BRACKET	1
35	11S05B		SCREW, set	1
36	267S07		WASHER, flat	2
37	61S05		NUT, "Binx", self-locking	1

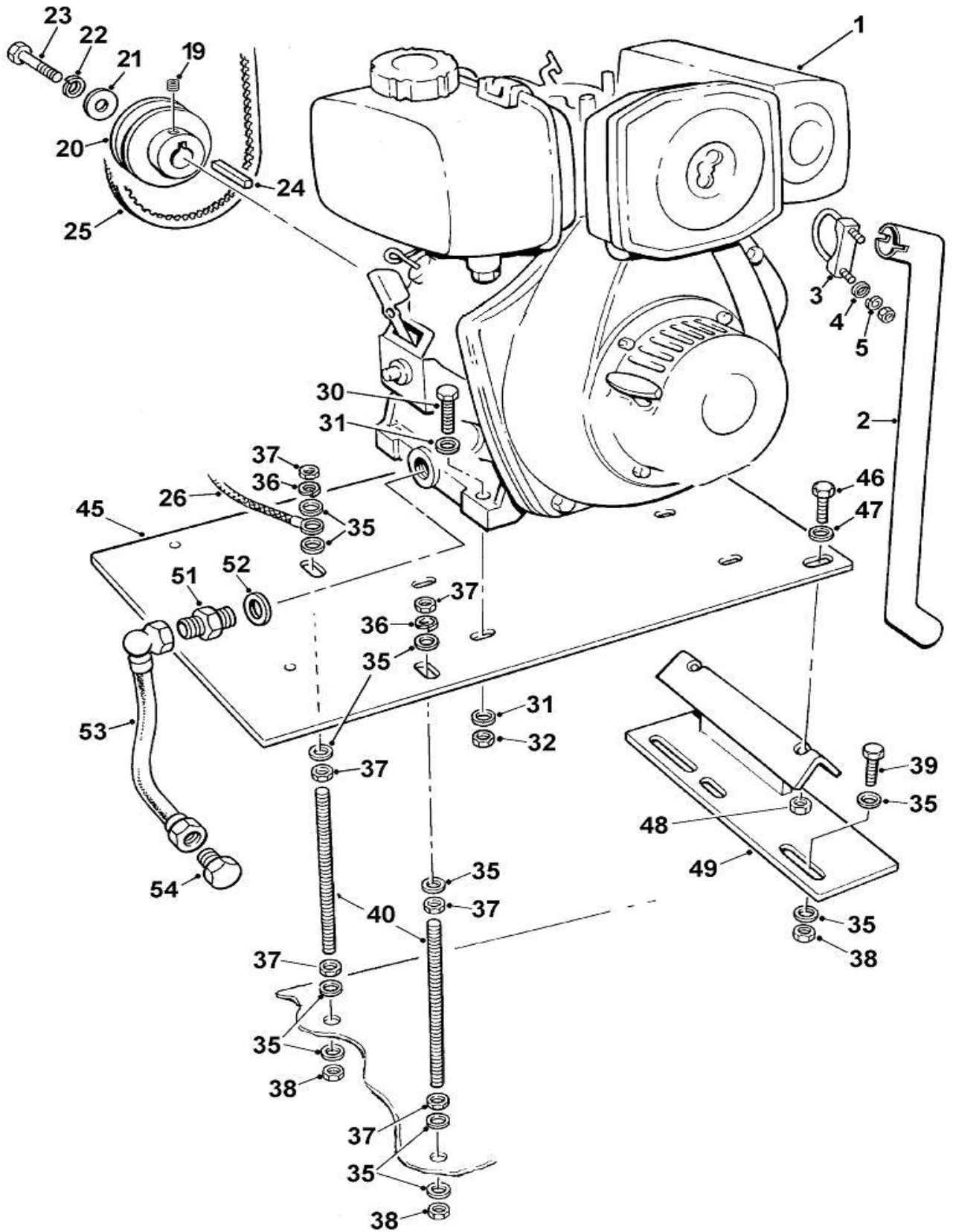

Engine & mounts

Item	Part no	Serial no	Description	Qty
Note: For Battery, start switch & loom, see page C-3				
1	V2005210	/1601	ENGINE, Yanmar L48ARE/L48N5SJ1 From Serial No 1353, L48ARE engine was replaced by the L48N5SJ1 Engines are interchangeable but check model when ordering spares For EU Stage 5 Emission Compliant Engine, L48V5VSJ1, see page C - 2A	1
2	513361600		PIPE, exhaust	1
3	153S02		CLAMP, exhaust	1
4	267S05		WASHER, flat	1
5	17S04		WASHER, spring	1
19	57S04D2		SCREW, grub	1
20	V2005220		PULLEY	1
21	V2004220		WASHER, 'Special'	1
22	17S04		WASHER, spring	1
23	8S03D		BOLT	1
24	305110550		KEY, parallel	1
25	397400700		BELT, 'V'	1
26		CABLE, negative (See page C-3)	1
30	8S03D		BOLT	4
31	267S05		WASHER, flat	8
32	61S03		NUT, self- locking "Binx"	4
35	267S07		WASHER, flat	13
36	17S06		WASHER, spring	2
37	7S05		NUT	6
38	61S05		NUT, self- locking "Binx"	4
39	11S05D		SCREW, set	3
40	513333100		STUD	2
45	513361800		PLATE, engine mounting	1
46	8S04D		BOLT	2
47	267S06		WASHER, flat	2
48	61S04		NUT, self- locking "Binx"	2
49	513358800		SUPPORT, bracket	1
51	325S04		ADAPTOR, male/male	1
52	298S05		SEAL, bonded	1
53	31S02LL		HOSE, engine oil drain	1
54	127S03		PLUG, blanking, engine oil drain	1

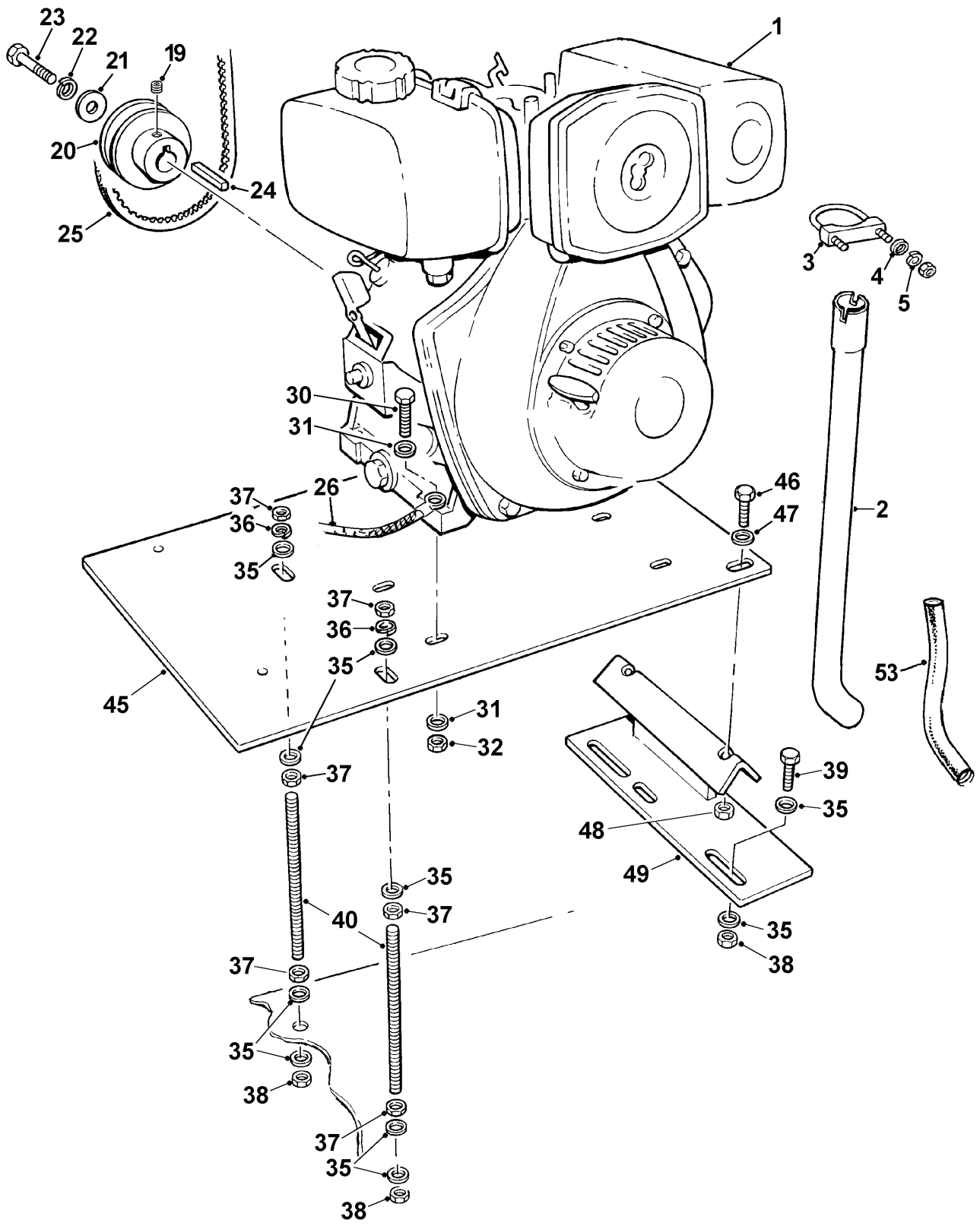

YANMAR L48V5VSJ1 (electric start)

C - 2A

Engine & mounts

Item	Part no	Serial no	Description	Qty
Note: For Battery, start switch & loom, see page C-3				
1	V2006401	1602/	ENGINE, Yanmar L48V5VSJ1 EU Stage 5 Emission Compliant	1
2	513371300	1602/	PIPE, exhaust	1
3	153S02		CLAMP, exhaust	1
4	267S05		WASHER, flat	1
5	17S04		WASHER, spring	1
19	57S04D2		SCREW, grub	1
20	V2005220		PULLEY	1
21	V2004220		WASHER, 'Special'	1
22	17S04		WASHER, spring	1
23	8S03D		BOLT	1
24	305110550		KEY, parallel	1
25	397400700		BELT, 'V'	1
26		CABLE, negative (See page C-3)	1
30	8S03D		BOLT	4
31	267S05		WASHER, flat	8
32	61S03		NUT, self- locking "Binx"	4
35	267S07		WASHER, flat	13
36	17S06		WASHER, spring	2
37	7S05		NUT	6
38	61S05		NUT, self- locking "Binx"	4
39	11S05D		SCREW, set	3
40	513333100		STUD	2
45	513361800		PLATE, engine mounting	1
46	8S04D		BOLT	2
47	267S06		WASHER, flat	2
48	61S04		NUT, self- locking "Binx"	2
49	513358800		SUPPORT, bracket	1
51	1602/	TAP, oil drain, not illustrated (refer to engine parts manual)	1
53	29S22	1602/	HOSE, engine oil drain, push on	1

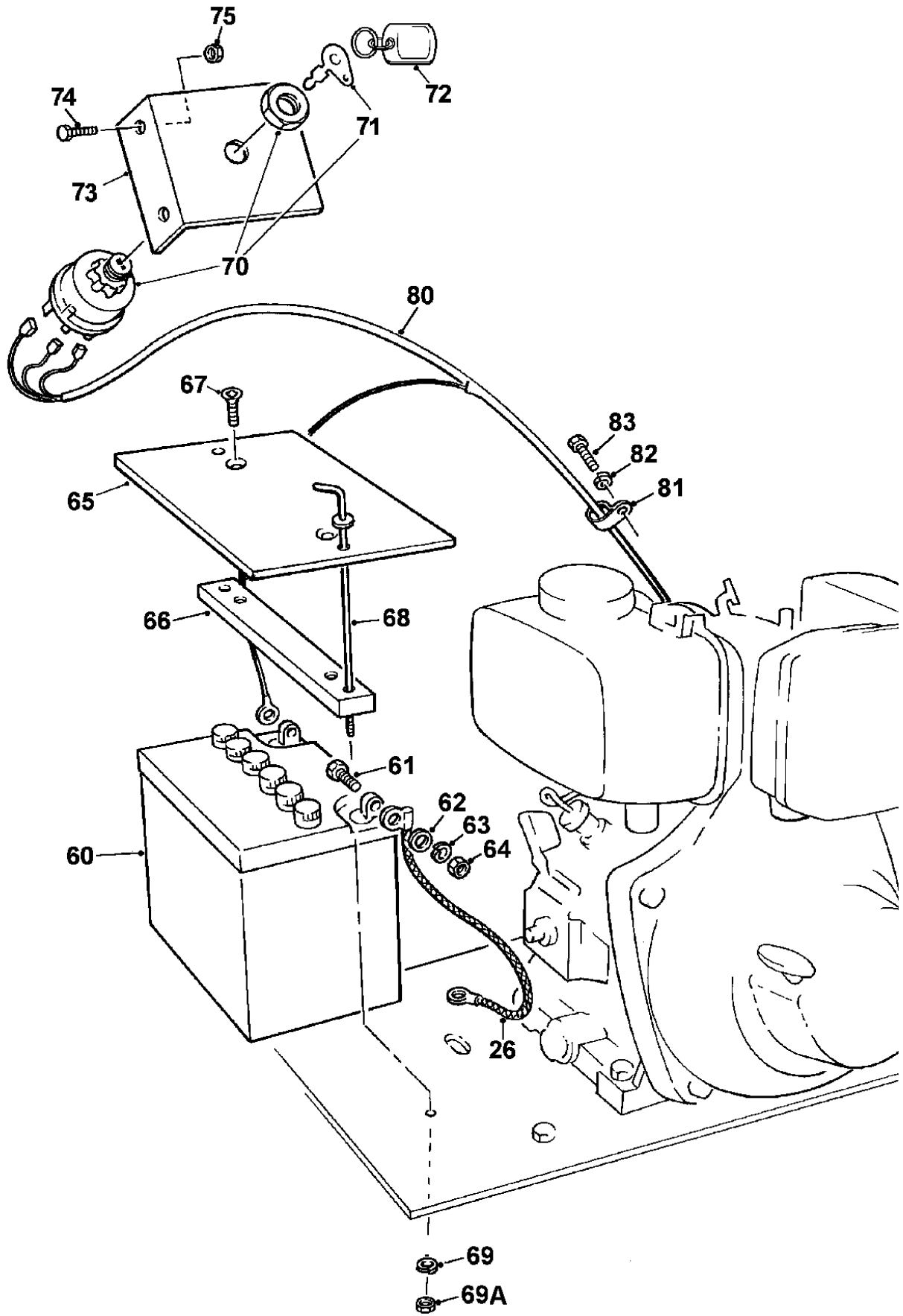

Battery, start switch & loom

Item	Part no	Serial no	Description	Qty
26	V2005211		CABLE, negative	1
60	109S11		BATTERY, 12 volt	1
61	11S02B		SCREW, set	1
62	267S04		WASHER, flat	1
63	17S03		WASHER, spring	1
64	7S02		NUT	1
65	513362000		COVER, battery	1
66	513361900		CLAMP, battery	1
67	52S02E		SCREW, counter sunk	2
68	513361700		ROD, battery clamp	2
69	17S03		WASHER, spring	2
69A	7S02		NUT	2
70	V2003561		SWITCH, start, c/w keys	1
71	V601179		KEY	2
72	V2003540		KEY RING	1
73	513359200		BRACKET, start switch	1
74	11S03A		SCREW, set	2
75	61S03		NUT, self-locking, 'Binx'	2
80	513362200		LOOM	1
81	V2005209		CLIP, 'P'	1
82	17S04		WASHER, spring	1
83	11S03A		SCREW, set	1

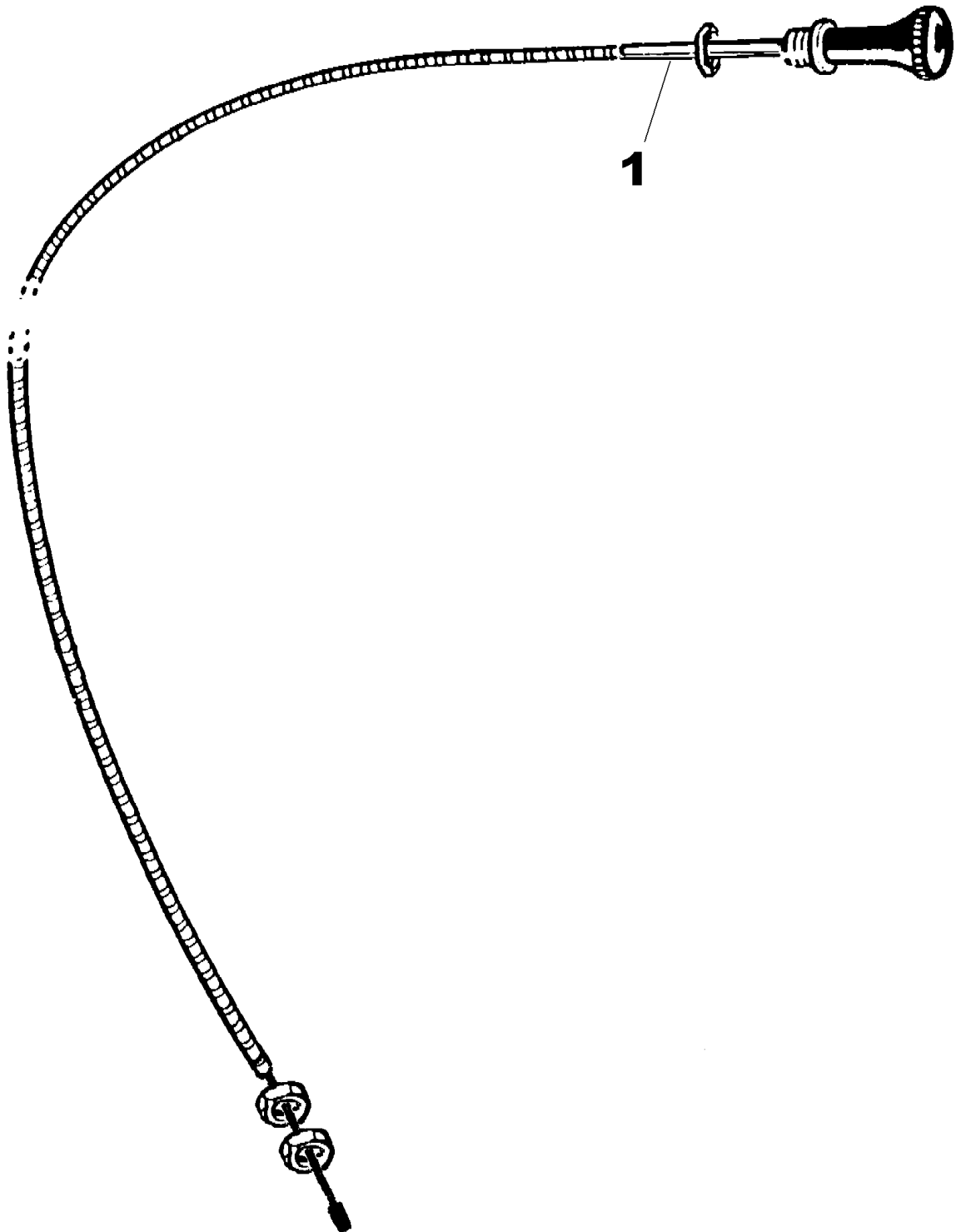

YANMAR L48N5SJ1/L48V5VSJ1 (electric start)

C - 4

CABLE, Emergency Stop

Item	Part no	Serial no	Description	Qty
		1526/		
1	513370900		CABLE, emergency stop	1
2	267S04		WASHER, flat	2
3	V2006398		TIE, Cable, panel mount	1

1 200 T

2

WINGET		<small>WINGET LIMITED P.O. Box 89, Smethurst Lane, Bolton, Lancs BL4 0WW Tel: (0204) 665165 Fax: (0204) 665206</small>	
Model			
Serial no.			
Engine no.	Power output		
Capacity	Weight kg.		
SRO	Year of man.		
<small>A Section Group Company</small>			

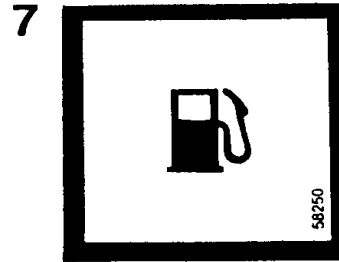

3

DANGER
KEEP ENGINE HOUSING
LID CLOSED WHEN
ENGINE IS RUNNING

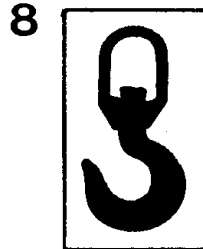

4

SAFETY WARNING

- 1 Before starting this machine, the operator should be familiar with the operating instructions issued by the manufacturer.
- 2 The manufacturer's rated capacity must never be exceeded.
- 3 Before carrying out any maintenance, servicing, or greasing, always ensure that the engine has been switched off. Never work on a machine while it is running.

58250/200T



5

WINGET

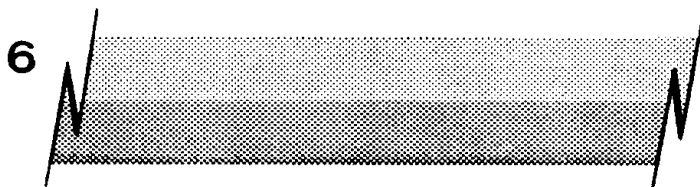

6A

	<p>IN COLD WEATHER, IF THE ENGINE IS HARD TO START, REMOVE THE RUBBER PLUG ON THE ROCKER COVER AND ADD NO MORE THAN 2cc OF ENGINE OIL BEFORE STARTING AS RECOMMENDED IN THE ENGINE OPERATORS HANDBOOK. ALWAYS REFIT THE RUBBER PLUG.</p> <p style="text-align: right;"><small>V2005276</small></p>
--	---

DECALS & PLATES**D - 1**

Item	Part no	Serial no	Description	Qty
1	V2003110		"200T"	2
2	V2003037		PLATE, serial number	1
2A	101S05B		RIVET, pop	4
3	504600900		WARNING, engine housing	1
4	504694600		WARNING, safety	2
5	V2003039		LOGO, "WINGET"	3
6	V2003038		STRIPE, bodywork	2
6A	V2005276		ENGINE COLD STARTING, Yanmar Not used with Yanmar L48V5	1
7	V2003101		DIESEL FUEL	1
8	V2003665		SLING POINTS	2
9	V2003598		BRITISH MADE	1

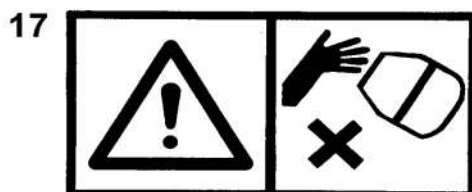
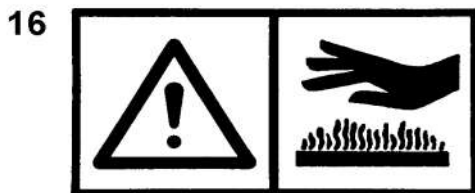
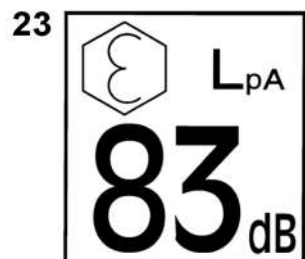
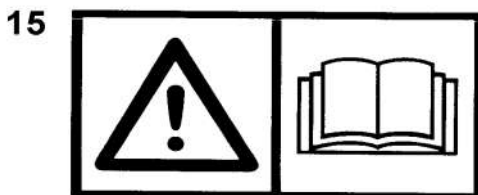
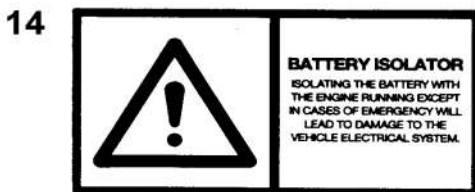
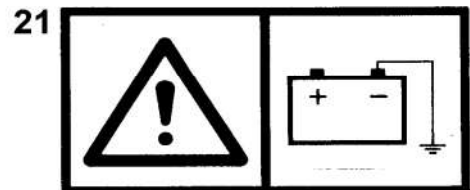
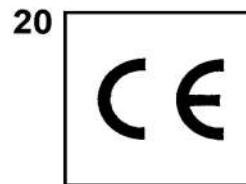
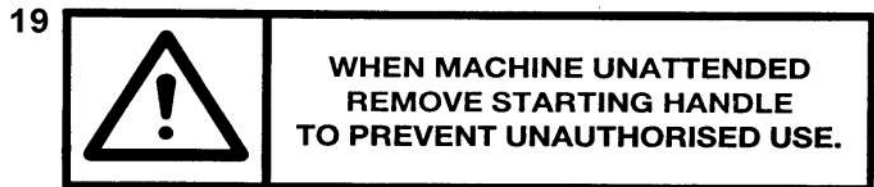
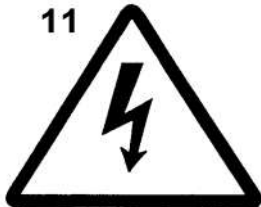

DECALS & PLATES**D - 1A**

Item	Part no	Serial no	Description	Qty
10	V2004302		ENGINE STOP	1
11	V2004307		ELECTRICAL HAZARD	2
12	V2004137		EAR PROTECTION	2
13	V2004744		EYE PROTECTION	2
14	V2004227		BATTERY ISOLATOR	1
15	V2004229		READ OPERATORS HANDBOOK	2
16	V2004282		HOT SURFACES	1
17	V2004289		HANDS CLEAR	2
18	V2005208		ENGINE STARTING PROCEDURE	1
19	V2004288		REMOVE STARTING HANDLE	1
20	V2004223		"CE" MARK <i>(Only applied to EC specification machines)</i>	1
21	V2004235		NEGATIVE EARTH	1
22	V2004281		ENTRAPMENT	1
23	V2003574		83 LPA	1
24	V2004132		102 LWA, Lister Petter engines	1

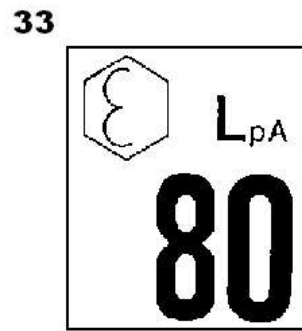
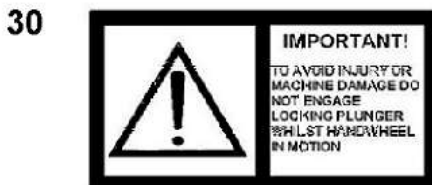
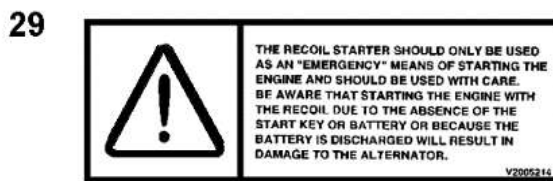
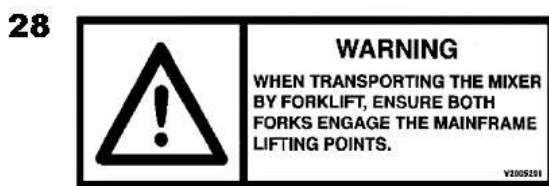
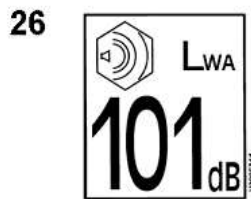

DECALS & PLATES**D - 1B**

Item	Part no	Serial no	Description	Qty
26	V2005311		101 LWA, Yanmar engines	1
27	V2005290		STOP ENGINE WITH RED BUTTON	1
28	V2005290		TRANSPORTING WITH FORKS	1
29	V2005214		RECOIL STARTER WARNING	1
30	V2005630		LOCKING PLUNGER	1
31	V2004119		NO LIFTING	2
32	513371100		EMERGENCY STOP	1
33	V2004130		80 LPA, Yanmar engines	1
34	V2006402		"UKCA" Mark <i>(Only applied to Mainland GB specification machines)</i>	1
35	V2006403		"UKNI" Mark <i>(Only applied to Northern Ireland specification machines)</i>	1

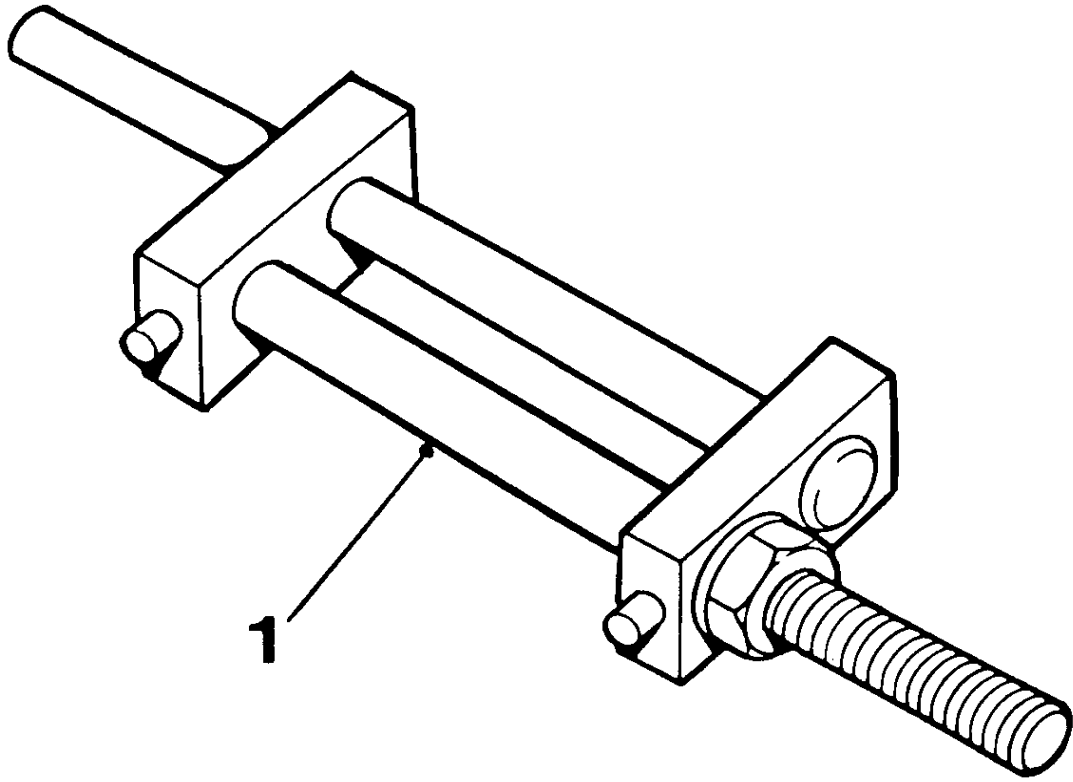

SPECIAL TOOLS

D - 2

Item	Part no	Serial no	Description	Qty
1	513204000		CLAMP, drum clip	1

CALIFORNIA

Proposition 65 Warning

Diesel engine exhaust and some of its constituents are known to the State of California to cause cancer, birth defects, and other reproductive harm

